

BALDOR® • RELIANCE 

Product Information Packet

1406W

5HP, 1500/1800RPM, 3PH, 50/60HZ, 3735M, GRND

Part Detail							
Revision:	X	Status:	PRD/A	Change #:		Proprietary:	No
Type:	AC	Elec. Spec:	G4WG0036	CD Diagram:	CD0258	Mfg Plant:	
Mech. Spec:	G14-116	Layout:	G4LY0116	Poles:	04	Created Date:	
Base:	RG	Eff. Date:	12-01-2016	Leads:	9#14		

Specs			
Nameplate Output:	5		
Product Style:	GRINDER		

Nameplate NP3412L

CAT.NO.	1406W		
HP	5	VOLTS	230
PHASE	3	AMPS	13.6
HZ	50//60	RPM	1500//1800
SER.NO			
SPEC.	G14-116E-0036G1		
BLANK			

Parts List		
Part Number	Description	Quantity
SA051809	SA G14-116E-0036G1	1.000 EA
RA046644	RA G14-116E-0036G1	1.000 EA
G4BA1000A01	BASE, MACH	1.000 EA
19XA3812A20	38-12X1 1/4 HEX WSHR HD TYPE AB	4.000 EA
HW1001A38	LOCKWASHER 3/8, ZINC PLT .688 OD, .382 I	4.000 EA
85XU0407S04	4X1/4 U DRIVE PIN STAINLESS	2.000 EA
52XF1032G04	S0-32 X 1/4, HX HD SR SL	2.000 EA
LD5000A01	LEAD ASSY, ML1400DF14 7" RING TRM EA END	1.000 EA
HA6194A05	BRACKET, 14" GRINDER FOR 'GE' MAGNETIC S	1.000 EA
G4GS5000	G14-23 GASKET X	1.000 EA
19XB2514A20	1/4-14X1-1/4 HX WS, TY B	2.000 EA
HW1001A25	LOCKWASHER 1/4, ZINC PLT .493 OD, .255 I	2.000 EA
HA2025A01	LEAD BUSHING	1.000 EA
RM1006A01	GROMMET,#2196:.75ID,.9375GROOVE DIA,.062	1.000 EA
52XN1032A04	10-32X1/4 HX HD SLTD SER X	3.000 EA
52XN1032A08	SCREW, SER HX SLT HD, ZN X	1.000 EA
XY1032A02	10-32 HEX NUT DIRECTIONAL SERRATION	2.000 EA
36CB4516	36 LIPPED CB LID - GALVANNEAL	1.000 EA
37GS1001SP	GASKET, CONDUIT BOX LID, .06 THICK LEXID	1.000 EA
51XW0832A07	8-32 X .44, TAPTITE II, HEX WSHR SLTD SE	4.000 EA
G4EP1900A01	ENDPLATE, MACH	2.000 EA
HW5100A11	W3917-042 WVY WSHR (WB)	2.000 EA
HA3104A14	THRUBOLT- 5/16-18 X12.125(OHIO)	4.000 EA
HW1001A31	LOCKWASHER 5/16, ZINC PLT.591 OD, .319 I	4.000 EA

Parts List (continued)		
Part Number	Description	Quantity
XY3118A12	5/16-18 HEX NUT DIRECTIONAL SERRATION	4.000 EA
G4FH1801A01	L.H. GRINDER GUARD, MACH	1.000 EA
10XN3816A20	3/8-16X1 1/4 HEX HD CAP	4.000 EA
HW1001A38	LOCKWASHER 3/8, ZINC PLT .688 OD, .382 I	4.000 EA
G4FH1800A01	R.H. GRINDER GUARD, MACH	1.000 EA
10XN3816A20	3/8-16X1 1/4 HEX HD CAP	4.000 EA
HW1001A38	LOCKWASHER 3/8, ZINC PLT .688 OD, .382 I	4.000 EA
G2AP1002A01SP	TOOL REST, MACH (G) MACHINED 6 ON	1.000 EA
HA6049A01SP	SUPPORT, TOOL REST, MACH	1.000 EA
10XN4420A24	7/16-20X1 1/2 HEX HD SCR	3.000 EA
HW1000A44	WASHER, 7/16 FLAT, ZN	3.000 EA
HW1001A44	WASHER,7/16 SPLT LK, ZN	3.000 EA
G2AP1002A01SP	TOOL REST, MACH (G) MACHINED 6 ON	1.000 EA
HA6049A01SP	SUPPORT, TOOL REST, MACH	1.000 EA
10XN4420A24	7/16-20X1 1/2 HEX HD SCR	3.000 EA
HW1000A44	WASHER, 7/16 FLAT, ZN	3.000 EA
HW1001A44	WASHER,7/16 SPLT LK, ZN	3.000 EA
G4FH1803A01	L.H. GRINDER GUARD COVER, MACH	1.000 EA
10XN3816A20	3/8-16X1 1/4 HEX HD CAP	4.000 EA
HW1001A38	LOCKWASHER 3/8, ZINC PLT .688 OD, .382 I	4.000 EA
G4FH1802A01	R.H. GRINDER GUARD COVER, MACH	1.000 EA
10XN3816A20	3/8-16X1 1/4 HEX HD CAP	4.000 EA
HW1001A38	LOCKWASHER 3/8, ZINC PLT .688 OD, .382 I	4.000 EA
HA6051	FLANGE, WHEEL, CAST	4.000 EA

Product Information Packet: 1406W - 5HP,1500/1800RPM,3PH,50/60HZ,3735M,GRND

HW3022J06	1/4X.625 ROLLED SPR PIN	2.000 EA
XZ2007A62SP	1 1/4-7 NUT LH HEX (NC)	1.000 EA
XZ2007A12SP	1 1/4-7 NUT RH HX(NC)(F/S	1.000 EA
G2AP1001ZP	SPARK BREAKER FOR 12" GRINDER GUARD	1.000 EA
10XN3816A16	3/8-16 X 1 HEX HD CAP SCREW	2.000 EA
HW1000A38	WASHER, 3/8" FLAT, SAE Z/P	2.000 EA
HW1001A38	LOCKWASHER 3/8, ZINC PLT .688 OD, .382 I	2.000 EA
G2AP1001ZP	SPARK BREAKER FOR 12" GRINDER GUARD	1.000 EA
10XN3816A16	3/8-16 X 1 HEX HD CAP SCREW	2.000 EA
HW1000A38	WASHER, 3/8" FLAT, SAE Z/P	2.000 EA
HW1001A38	LOCKWASHER 3/8, ZINC PLT .688 OD, .382 I	2.000 EA
MJ1000A02	GREASE, MOBIL POLYREX EM - 124047	0.050 LB
HA1000A59	.020 BEARING GUARD 3.931 OD	2.000 EA
GA9	EYESHIELD ASSY	1.000 EA
MG1000G01	MUNSELL 5.93PB 3.81/ 2.71	0.017 GA
LB1009N	LABEL,ROTATION DIRECTION (ON ROLLS)	1.000 EA
LB1031	LABEL, WARNING X	1.000 EA
LB1112	LABEL GRDR STARTER BOX GR	1.000 EA
LB5010	TAG, CAUTION PRINT SHOP	1.000 EA
MN909	EYESHIELD MTG INSTR. FOR GA9, GA10 & GA1	1.000 EA
CN1900A03	MAGNETIC STARTER 'GE' NO. CR306C10300AAA	1.000 EA
CN2006151B	HEATER, 'GE' NO. CR123C151B (FOR 'GE' ST	3.000 EA
LB1119N	WARNING LABEL	1.000 EA
NP3412L	ALUM NP FOR 8" UTILITY GRINDERS-BUFFERS	1.000 EA
G4PA1000	PACKAGING GROUP	1.000 EA
MN903	INSTR MANUAL FOR GRINDERS 9/03	1.000 EA

Accessories		
Part Number	Description	Multiplier
GA20	PEDESTAL INDUSTRIAL, CAST IRON 8"-14"	A8
GA9	PAIR LIGHTED EYESHIELDS	A8
GA9-1	SINGLE LIGHTED EYESHIELD	A8
GA9S	PAIR EYESHIELDS W/ ON-OFF SWITCH	A8
GA11	PAIR EYESHIELDS	A8
B147	14" 30 GRIT GRINDING WHEEL	A8
B148	14" 46 GRIT GRINDING WHEEL	A8
DC14-3	DUST CONTROL FOR 14 IN GRINDER	A8

AC Induction Motor Performance Data

Record # 23658 - Preliminary Data Sheet

Winding: G4WG0036-R001	Type: 3735M	Enclosure: TENV
-------------------------------	--------------------	------------------------

Nameplate Data				460 V, 60 Hz: High Voltage Connection	
Rated Output (HP)	5			Full Load Torque	15.1 LB-FT
Volts	208-230/460			Start Configuration	direct on line
Full Load Amps	15-13.6/6.8//15/6.8			Breakdown Torque	50.4 LB-FT
R.P.M.	1500//1800			Pull-up Torque	21.4 LB-FT
Hz	50//60	Phase	3	Locked-rotor Torque	29.1 LB-FT
NEMA Design Code	B	KVA Code	H	Starting Current	38.7 A
Service Factor (S.F.)	1			No-load Current	2.43 A
NEMA Nom. Eff.	0	Power Factor	0	Line-line Res. @ 25°C	2.24 Ω
Rating - Duty	40C AMB-CONT			Temp. Rise @ Rated Load	
				Locked-rotor Power Factor	40
				Rotor inertia	0.74 LB-FT ²

Load Characteristics 460 V, 60 Hz, 5 HP

% of Rated Load	25	50	75	100	125	150
Power Factor	53	74	83	87	90	90
Efficiency	76.9	84.7	86.7	87.1	86.5	85.5
Speed	1784	1770	1755	1739	1721	1702
Line amperes	2.87	3.74	4.87	6.15	7.56	9.09

Performance Graph at 460V, 60Hz, 5.0HP Typical performance - Not guaranteed values

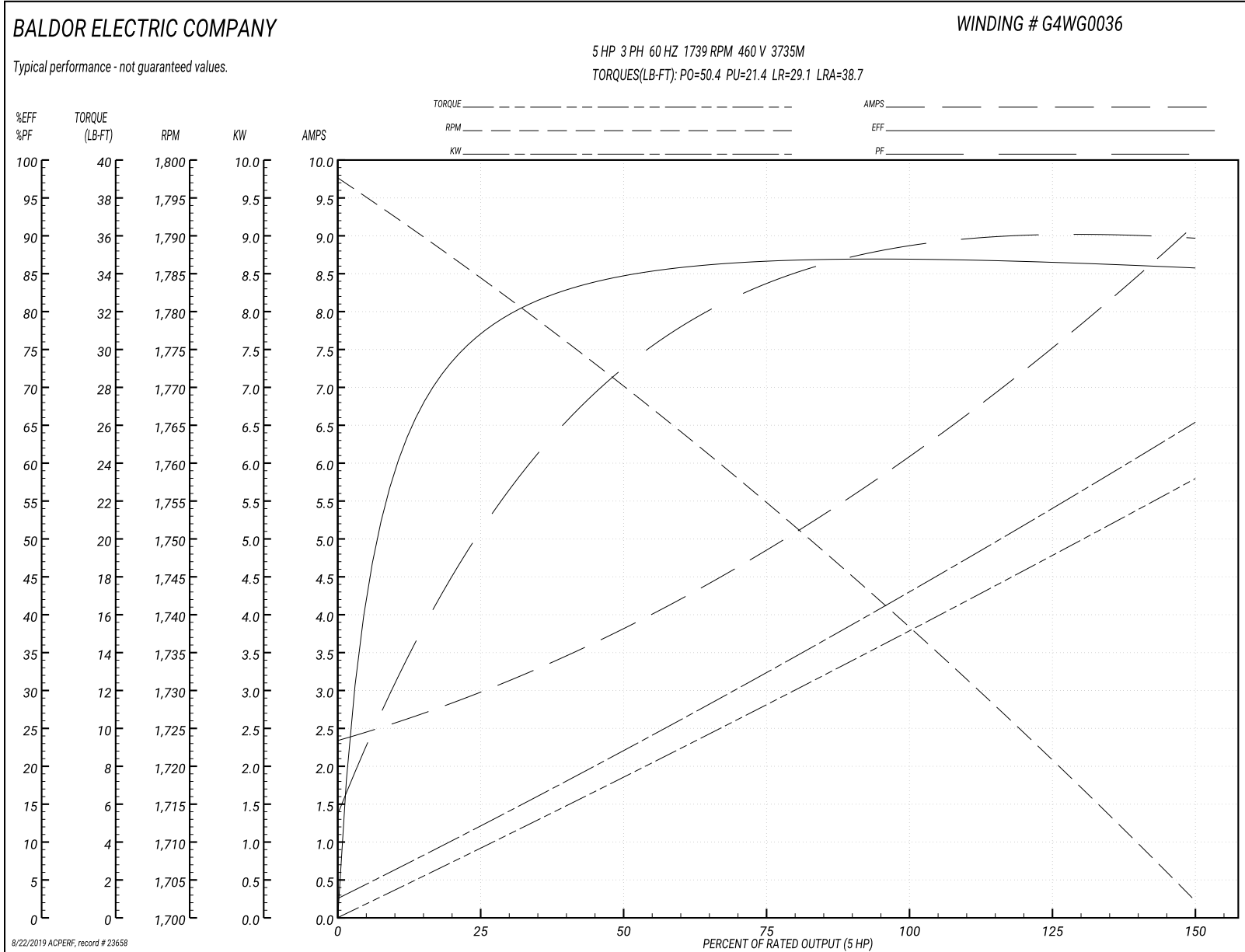

AC Induction Motor Performance Data

Record # 23659 - Preliminary Data Sheet

Winding: G4WG0036-R001	Type: 3735M	Enclosure: TENV
-------------------------------	--------------------	------------------------

Nameplate Data				460 V, 50 Hz: High Voltage Connection	
Rated Output (HP)	5			Full Load Torque	18.1 LB-FT
Volts	208-230/460			Start Configuration	direct on line
Full Load Amps	15-13.6/6.8//15/6.8			Breakdown Torque	71.6 LB-FT
R.P.M.	1500//1800			Pull-up Torque	35.3 LB-FT
Hz	50//60	Phase	3	Locked-rotor Torque	47.8 LB-FT
NEMA Design Code	B	KVA Code	H	Starting Current	46 A
Service Factor (S.F.)	1			No-load Current	3.33 A
NEMA Nom. Eff.	0	Power Factor	0	Line-line Res. @ 25°C	2.24 Ω
Rating - Duty	40C AMB-CONT			Temp. Rise @ Rated Load	
				Locked-rotor Power Factor	47
				Rotor inertia	0.74 LB-FT ²

Load Characteristics 460 V, 50 Hz, 5 HP

% of Rated Load	25	50	75	100	125	150
Power Factor	43	64	76	83	86	88
Efficiency	73.7	82.7	85.4	86	85.7	84.9
Speed	1487	1475	1462	1449	1434	1419
Line amperes	3.67	4.4	5.4	6.58	7.91	9.36

Performance Graph at 460V, 50Hz, 5.0HP Typical performance - Not guaranteed values

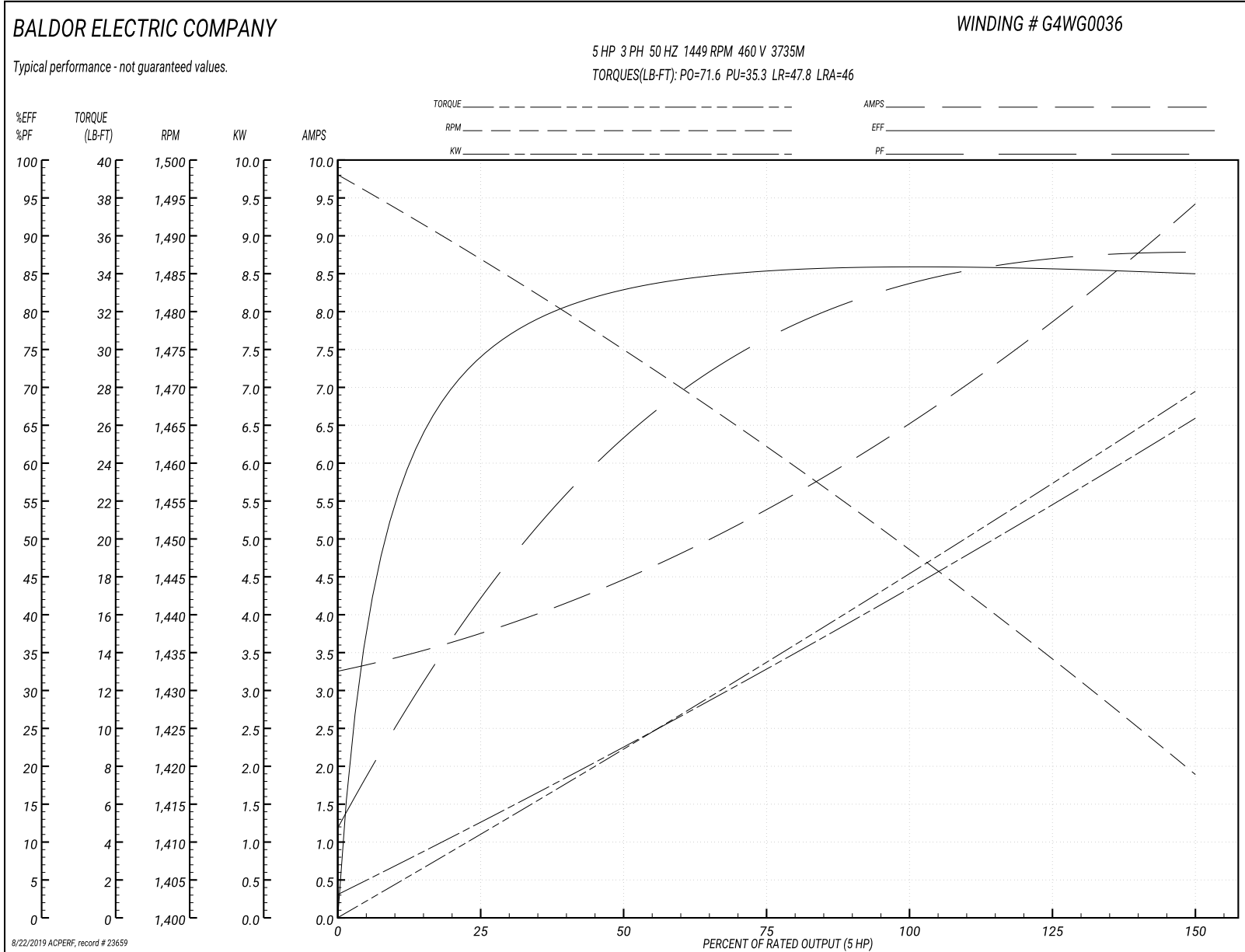

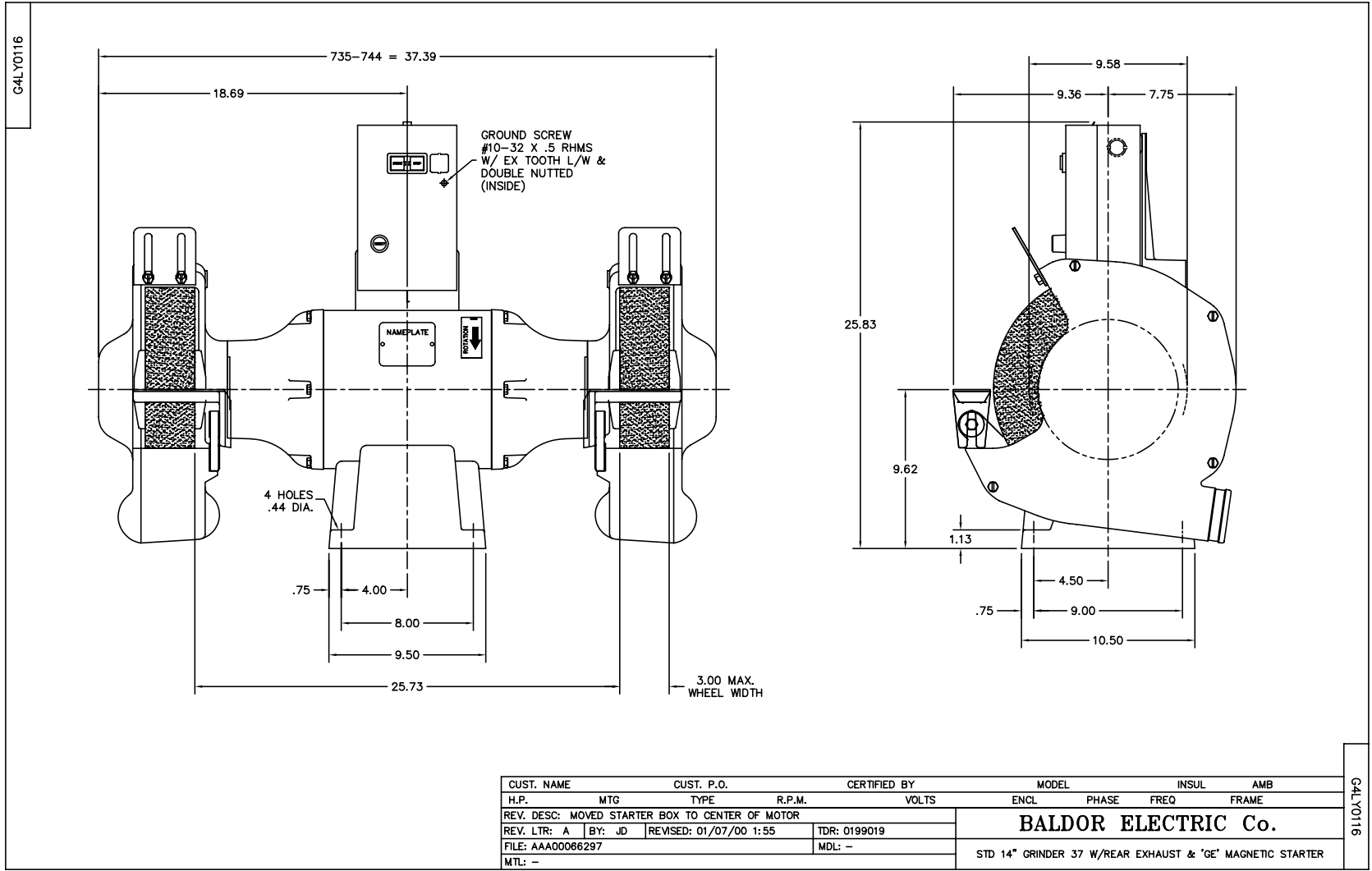

CD0258

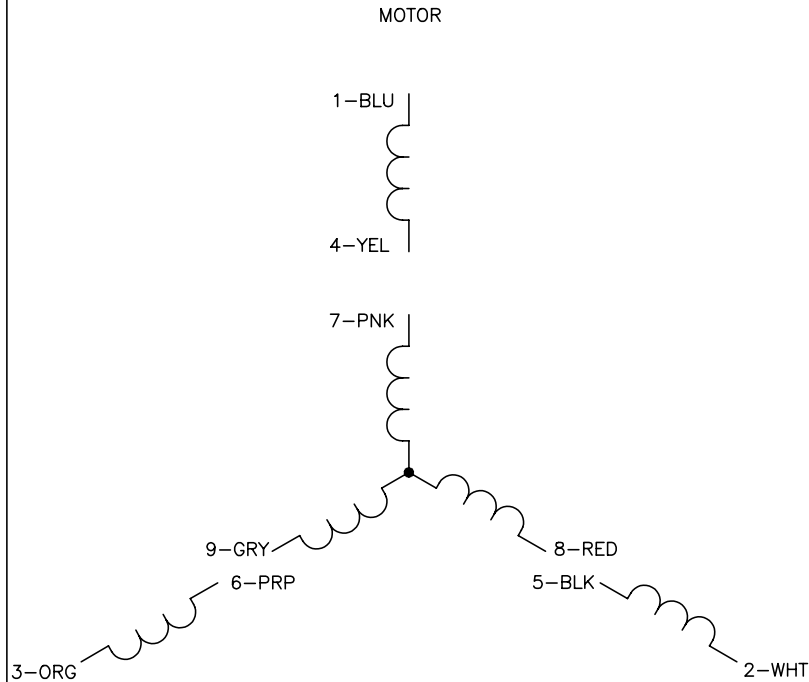

- NOTES:
1. GROUND BASE TO BAND.
 2. LEAD COLORS ARE OPTIONAL. LEADS MUST ALWAYS BE NUMBERED AS SHOWN.

STARTER BRACKET CONDUIT BOX

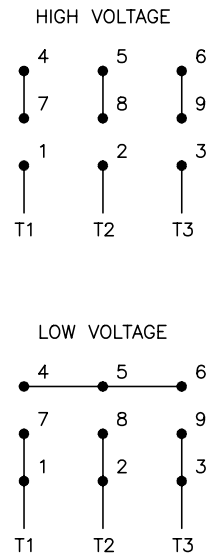

NOTE:
THE MOTOR IS FACTORY CONNECTED FOR THE SAME VOLTAGE AS THE MAGNETIC STARTER. A MAGNETIC STARTER FOR THE PROPER VOLTAGE EQUIPPED WITH THE CORRECT HEATER ELEMENTS WILL BE NEEDED FOR A VOLTAGE CONNECTION CHANGE.

STARTER

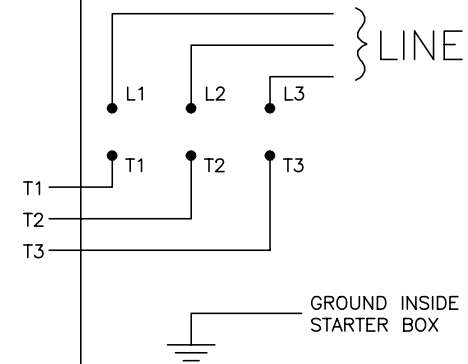

NOTE:
INTERCHANGE ANY TWO LINE LEADS TO REVERSE ROTATION.

REV. DESC: REVISE TO SHOW OPTIONAL COLORS			
REV. LTR: C	BY: EAH	REVISED: 05/05/99 11:35	TDR: 0179909
8200		FILE: AAA00051260	MDL: -
CD0258		MTL: -	

BALDOR ELECTRIC Co.

3PH, DV, 9 LEAD, GRINDER OR BUFFER W/MAGNETIC STARTER

CD0258