

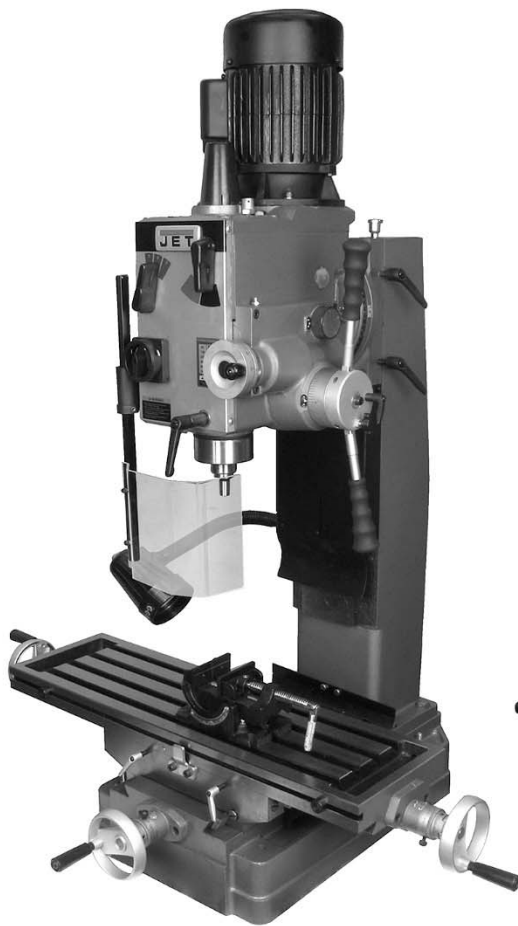

# Operating Instructions and Parts Manual Geared Head Mill-Drill Machines

Models: JMD-40GH, JMD-40GHPF, JMD-45GH, JMD-45GHPF



JMD-45GHPF



JMD-40GH

**JET**  
427 New Sanford Road  
LaVergne, Tennessee 37086  
Ph.: 800-274-6848  
www.jettools.com

**Part No. M-351040**  
Edition 2 03/2017  
ECR 171106155622  
Copyright © 2017 JET



## 1.0 IMPORTANT SAFETY INSTRUCTIONS

### WARNING – To reduce risk of injury:

1. Read and understand the entire owner's manual before attempting assembly or operation.
2. Read and understand the warnings posted on the machine and in this manual. Failure to comply with all of these warnings may cause serious injury.
3. Replace the warning labels if they become obscured or removed.
4. This mill-drill machine is designed and intended for use by properly trained and experienced personnel only. The manual is not, nor was it intended to be, a training manual. If you are not familiar with the proper and safe operation of a mill-drill, do not use until proper training and knowledge have been obtained.
5. Do not use this mill-drill for other than its intended use. If used for other purposes, JET disclaims any real or implied warranty and holds itself harmless from any injury that may result from that use.
6. Always wear protective eye wear when operating machinery. Eye wear shall be impact resistant, protective safety glasses with side shields which comply with ANSI Z87.1 specifications. Use of eye wear which does not comply with ANSI Z87.1 specifications could result in severe injury from breakage of eye protection. (Everyday eyeglasses only have impact resistant lenses; they are NOT safety glasses.)
7. Before operating this machine, remove tie, rings, watches and other jewelry, and roll sleeves up past the elbows. Do not wear loose clothing. Confine long hair. Non-slip footwear or anti-skid floor strips are recommended. Do not wear gloves.
8. Wear ear protectors (plugs or muffs) if sound exceeds safe levels.
9. CALIFORNIA PROPOSITION 65 WARNING: This product contains chemicals known to the State of California to cause cancer, or birth defects or other reproductive harm.
10. This product, when used for welding, cutting, or working with metal, produces fumes, gases, or dusts which contain chemicals known to the State of California to cause birth defects and, in some cases, cancer. (California Health and Safety Code Section 25249.5 et seq.)
11. Make certain the switch is in the OFF position before connecting the machine to the power supply.
12. Make certain the machine is properly grounded.
13. Make all machine adjustments or maintenance with the machine unplugged from the power source.
14. Remove adjusting keys and wrenches. Form a habit of checking to see that keys and adjusting wrenches are removed from the machine before turning it on.
15. Keep safety guards in place at all times when the machine is in use. If removed for maintenance purposes, use extreme caution and replace the guards immediately after completion of maintenance.
16. Check damaged parts. Before further use of the machine, a guard or other part that is damaged should be carefully checked to determine that it will operate properly and perform its intended function. Check for alignment of moving parts, binding of moving parts, breakage of parts, mounting and any other conditions that may affect its operation. A guard or other part that is damaged should be properly repaired or replaced.
17. Provide for adequate space surrounding work area and non-glare, overhead lighting.
18. Keep the floor around the machine clean and free of scrap material, oil and grease.
19. Keep visitors a safe distance from the work area. Keep children away.
20. Make your workshop child proof with padlocks, master switches or by removing starter keys.
21. Give your work undivided attention. Looking around, carrying on a conversation and "horse-play" are careless acts that can result in serious injury.
22. Maintain a balanced stance at all times so that you do not fall into the blade or other moving parts. Do not overreach or use excessive force to perform any machine operation.
23. Use the right tool at the correct speed and feed rate. Do not force a tool or attachment to do a job for which it was not designed. The right tool will do the job better and more safely.
24. Feed work into a blade or cutter against the direction of rotation of the blade or cutter only.
25. Use recommended accessories; improper accessories may be hazardous.

26. Maintain tools with care. Keep cutters sharp and clean for the best and safest performance. Follow instructions for lubricating and changing accessories.
27. Turn off the machine before cleaning. Use a brush or compressed air to remove chips or debris — do not use bare hands.
28. Do not stand on the machine. Serious injury could occur if the machine tips over.
29. Never leave the machine running unattended. Turn the power off and do not leave the machine until it comes to a complete stop.
30. Remove loose items and unnecessary work pieces from the area before starting the machine.
31. Do not perform any setup work while machine is operating.
32. Do not place hands near cutter while machine is operating.
33. Don't use in dangerous environment. Don't use power tools in damp or wet location, or expose them to rain. Keep work area well lighted.
34. All work shall be secured using either clamps or a vise to the drill press table. It is unsafe to use your hands to hold any workpiece being drilled.
35. Use proper extension cord. Make sure your extension cord is in good condition. When using an extension cord, use one heavy enough to carry the current your product will draw. An undersized cord will cause a drop in line voltage resulting in loss of power and overheating. Sect. 6.3, Table 2 shows correct size to use depending upon cord length and nameplate ampere rating. If in doubt, use the next heavier gauge. The smaller the gauge number, the heavier the cord.

**Familiarize yourself with the following safety notices used in this manual:**

**CAUTION** This means that if precautions are not heeded, it may result in minor injury and/or possible machine damage.

**WARNING** This means that if precautions are not heeded, it may result in serious, or possibly even fatal, injury.

## 1.1 Switch lock-out

To prevent unauthorized use or accidental starting of the Mill-Drill, insert padlock (not provided) through holes in switch. See Figure 1-1. Store key in a secure place.

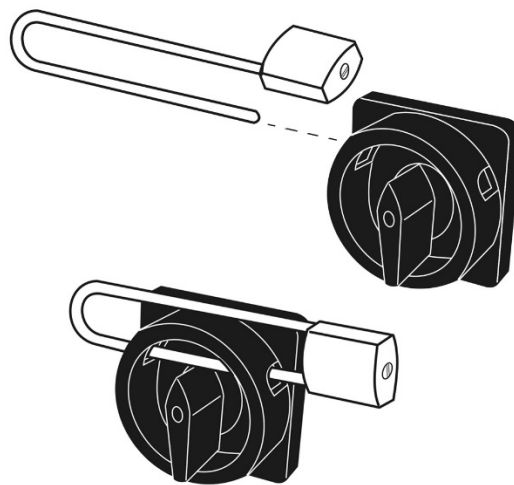

Figure 1-1

## 2.0 Table of contents

Section	Page
1.0 IMPORTANT SAFETY INSTRUCTIONS .....	2
1.1 Switch lock-out .....	3
2.0 Table of contents.....	4
3.0 About this manual .....	5
4.0 Specifications.....	6
4.1 Mounting hole centers .....	7
5.0 Setup and assembly.....	8
5.1 Shipping contents.....	8
5.2 Tools required for assembly .....	8
5.3 Unpacking and cleanup.....	8
5.4 Location.....	8
5.5 Assembly.....	8
5.6 Lubrication.....	9
6.0 Electrical connections .....	9
6.1 GROUNDING INSTRUCTIONS .....	9
6.2 Voltage conversion.....	10
6.3 Extension cords.....	10
6.4 Overload re-set button.....	10
7.0 Adjustments .....	10
7.1 Removing and installing arbors .....	10
7.2 Head adjustments .....	10
7.3 Table adjustments .....	11
7.4 Gib adjustments .....	11
7.5 Spindle return .....	11
8.0 Operation .....	12
8.1 Operating controls .....	12
8.2 Powerfeed operation (models 40GHPF and 45GHPF only).....	12
8.3 Manual coarse feed.....	13
8.4 Manual fine feed.....	13
8.5 Basic milling procedure .....	13
9.0 User-maintenance.....	13
9.1 General maintenance .....	13
9.2 Additional servicing .....	13
9.3 Lubrication.....	14
10.0 Troubleshooting JMD-40GH/45GH series Mill-Drills.....	15
11.0 Optional accessories.....	16
12.0 Replacement Parts.....	16
12.1.1 JMD-40GH,-40GHPF Table, Base, and Column Assembly – Exploded View .....	17
12.1.2 JMD-40GH,-40GHPF Table, Base, and Column Assembly – Parts List.....	18
12.2.1 JMD-40GH,-45GH (non-powerfeed) Gear Head Assembly – Exploded View .....	20
12.2.2 JMD-40GH,-45GH (non-powerfeed) Gear Head Assembly – Parts List .....	21
12.3.1 JMD-40GH,-45GH (non-powerfeed) Gears Assembly – Exploded View .....	24
12.3.2 JMD-40GH,-45GH (non-powerfeed) Gears Assembly – Parts List.....	25
12.4.1 JMD-40GHPF,-45GHPF (powerfeed) Gear Head Assembly – Exploded View .....	26
12.4.2 JMD-40GHPF,-45GHPF (powerfeed) Gear Head Assembly – Parts List .....	27
12.5.1 JMD-40GHPF,-45GHPF (powerfeed) Gears Assembly- Exploded View .....	30
12.5.2 JMD-40GHPF,-45GHPF (powerfeed) Gears Assembly – Parts List .....	31
12.6.1 JMD-45GH,-45GHPF Table and Base Assembly – Exploded View.....	32
12.6.2 JMD-45GH,-45GHPF Table and Base Assembly – Parts List .....	33
12.7.1 JMD-45GH,-45GHPF Square Column Assembly – Exploded View.....	35
12.7.2 JMD-45GH,-45GHPF Square Column Assembly – Parts List.....	36
13.0 Electrical Connections, JMD-40GH/45GH series.....	37
13.1 Wiring Diagram 115V .....	37
13.2 Wiring Diagram 230V .....	38
14.0 Warranty and service .....	39

## 3.0 About this manual

This manual is provided by JET, covering the safe operation and maintenance procedures for the JET JMD-40GH and JMD-45GH series Geared Head Mill-Drills. This manual contains instructions on installation, safety precautions, general operating procedures, maintenance instructions and parts breakdown. Your machine has been designed and constructed to provide consistent, long-term operation if used in accordance with the instructions as set forth in this document.

This manual is not intended to be a training guide for milling/drilling operations, or tool and workpiece selection. Consult a machinery handbook or shop supervisor for information on proper speed and feed rates for specific materials, or type of cutter or drill suitable for a particular operation. Whatever accepted methods or materials are used, always make personal safety a priority.

If there are questions or comments, please contact your local supplier or JET. JET can also be reached at our web site: [www.jettools.com](http://www.jettools.com).

Retain this manual for future reference. If the machine transfers ownership, the manual should accompany it.

Note that illustrations in this manual may or may not show your exact machine model.

** **WARNING** Read and understand the entire contents of this manual before attempting assembly or operation! Failure to comply may cause serious injury!**

Register your product using the mail-in card provided, or register online:  
<http://www.jettools.com/us/en/service-and-support/warranty/registration/>

## 4.0 Specifications

Table 1

Model number	JMD-40GH	JMD-40GHPF	JMD-45GH	JMD-45GHPF
Stock number	351040	351041	351045	351046
<b>Motor and Electricals</b>				
Motor type	Totally-enclosed, fan-cooled, induction			
Horsepower	1.5			
Phase	single			
Voltage	115/230 (prewired 115V)			
Cycle	60 Hz			
Listed FLA (full load amps)	20 / 10			
Starting amps	68A/34A			
Running amps (no load)	16.8A /8.4A			
Start capacitor	400MFD 125VAC			
Motor speed	1720 RPM			
Motor cord	AWM 600V 15AWG			
Power cord	SJT 3x3.31mm <sup>2</sup> 12AWG 300V, 6 ft.			
Power plug installed	20A (5-20P)			
LED work lamp	12V, 6W; separate 115V power cord SJT 3x18AWG, 6 ft.			
Recommended circuit size <sup>1</sup>	20A / 15A			
Sound emission without load <sup>2</sup>	70dB			
<b>Capacities</b>				
Spindle taper	R8			
Spindle rotation	Forward/Reverse			
Drilling capacity	Mild steel	1-1/4 in. (32mm)		
	Cast iron	1-1/2 in. (38mm)		
Face mill capacity	Ø 4 in. (100mm)			
End mill capacity	Ø 3/4 in. (20mm)			
Swing	20-1/2 in. (520mm)		19-11/16 in. (500mm)	
Max. distance spindle to table	15-3/4 in. (400mm)		18-1/8 in. (460mm)	
Spindle travel (manual)	5 in. (130mm)			
Spindle travel (power feed)	n/a	4-1/4 in. (107mm)	n/a	4-1/4 in. (107mm)
Number of spindle speeds	6			
Range of spindle speeds	65, 130, 220, 480, 925, 1550 RPM			
Number of power feeds	n/a	3	n/a	3
Range of power feeds	n/a	0.005, 0.007, 0.010 in. (0.12/0.18/0.2mm)	n/a	0.005, 0.007, 0.010 in. (0.12/0.18/0.2mm)
Head pivot around column	360 deg.			
Head swivel	90 deg. left, 30 deg. right			
Max. table travel (longitudinal)	20-1/2 in. (520mm)			
Max. cross travel	8-1/4 in. (210mm)			
<b>Main materials</b>				
Column	Cast iron			
Table	Cast iron			
Head	Cast iron			
<b>Dimensions</b>				
Quill diameter	3 in. (75mm)			
Column diameter	4-1/2 in. (115mm)		n/a (square design)	
Table working surface (LxW)	32-1/4 x 9-1/2 in. (820 x 240mm)			
Number of T-slots	4			
T-slot size (WxD)	5/8 x 1 in. (16 x 26mm)			
Base dimensions	24-1/4 x 15-15/16 in. (615 x 405mm)		26-11/16 x 15-15/16 in. (653 x 405mm)	

	<b>JMD-40GH</b>	<b>JMD-40GHPF</b>	<b>JMD-45GH</b>	<b>JMD-45GHPF</b>
Overall assembled (LxWxH)	28 x 39-1/4 x 42-1/2 in. (709 x 995 x 1079 mm)		29 x 36 x 50 in. (736 x 914 x 1270 mm)	
Shipping dimensions (LxWxH)	29-3/4 x 37-1/2 x 49 in. (755 x 950 x 1242 mm)		36 x 30 x 52 in. (915 x 763 x 1320 mm)	
<b>Weights</b>				
Net weight	628 lb (285 kg)	655 lb (297 kg)	728 lb (330 kg)	754 lb (342 kg)
Shipping weight	694 lb (315 kg)	721 lb (327 kg)	794 lb (360 kg)	820 lb (372 kg)

<sup>1</sup> subject to local and national electrical codes.

<sup>2</sup> The specified values are emission levels and are not necessarily to be seen as safe operating levels. As workplace conditions vary, this information is intended to allow the user to make a better estimation of the hazards and risks involved only.

L = length, W = width, H = height, D = depth

n/a = not applicable

The specifications in this manual were current at time of publication, but because of our policy of continuous improvement, JET reserves the right to change specifications at any time and without prior notice, without incurring obligations.

#### 4.1 Mounting hole centers

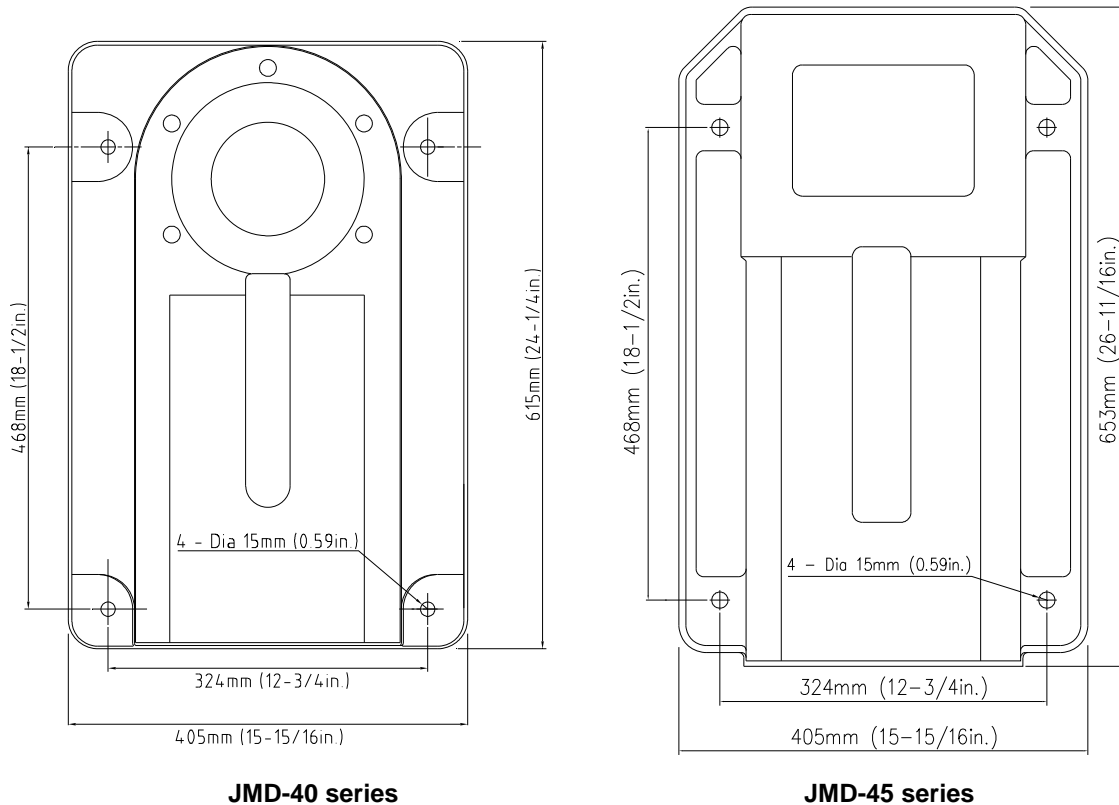

Figure 4-1

**⚠WARNING** Read and understand all assembly and setup instructions before attempting assembly. Failure to comply may cause serious injury.

## 5.0 Setup and assembly

### 5.1 Shipping contents

See Figure 5-1

- 1 Mill-Drill (not shown)
- 2 Drill arbor (*pre-installed*)
- 1 Draw bar R8-7/16 in. (*pre-installed*)
- 3 Handwheels – A
- 1 Face mill cutter assembly 3in. (74mm) – B
- 1 Face mill cutter arbor – C
- 4 Small handles – D
- 1 Crank handle – E
- 3 Downfeed handles – F (*non-powerfeed models only*)
- 1 Drill chuck with key 13mm/JT6 – G
- 1 Socket wrench – H
- 1 Box wrench 17/19mm – H1
- 3 Hex wrenches, 3/4/5mm – J
- 1 Hardware package (see *sect. 12.1.2*):
  - 2 Bolts – K
  - 2 Flat washers – L
  - 2 Hex nuts – M
- 1 Socket hd cap screw 3/8x1 – N
- 1 Flat washer 3/8 – O
- 1 Angle vise 3-inch – P
- 1 Plum wrench – Q
- 1 Operating instructions and parts list
- 1 Product registration card

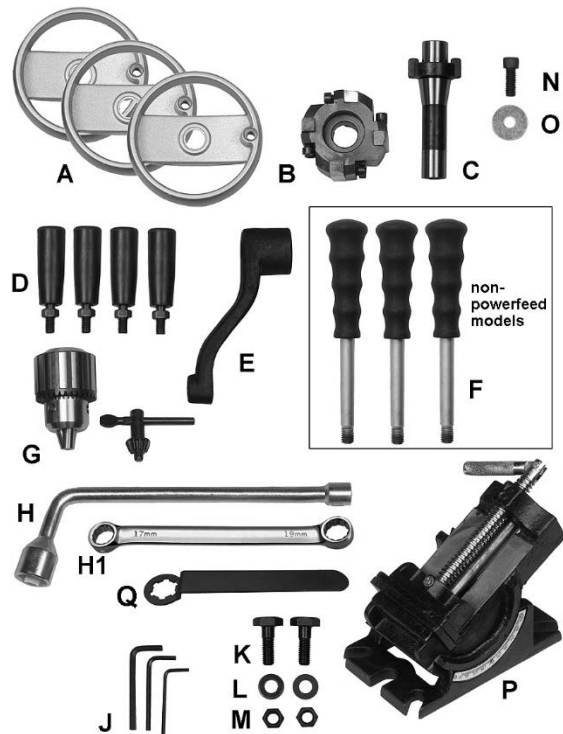

Figure 5-1: contents (not to scale)

### 5.2 Tools required for assembly

- Cross-point (Phillips) screwdriver
- 14mm open-end (or adjustable) wrench
- 3mm and 5mm hex wrenches (provided)

### 5.3 Unpacking and cleanup

1. Inspect contents for shipping damage. Report damage, if any, to your distributor. Do not discard shipping materials until Mill-Drill is installed and running properly.
2. Compare contents of shipping carton with the contents list in this manual. Report shortages, if any, to your distributor. Note: Check machine first in case some parts are pre-installed.
3. Remove rust protectant from exposed surfaces with a clean rag and cleaner/degreaser or kerosene. Avoid getting solvents on rubber or plastic parts.
4. Apply a light coat of oil to exposed metal surfaces to inhibit rust.

### 5.4 Location

**⚠WARNING** Machine is heavy; use appropriate lifting device and exercise caution when moving to final location. Failure to comply may cause serious injury.

1. The location for the mill-drill should be dry, with good overhead lighting and room enough for head to rotate 360° around column, for maximum table travel, loading and offloading of stock, and general maintenance.
2. Before bolting mill-drill to a bench or stand, the unit must be level: Place a level on table in both directions. If table is not level, shim under the low corner(s) until level. Tighten fastening bolts. (See Figure 4-1 for mounting hole spacing.)
3. Check for level again. Adjust as necessary until mill-drill is level after fastening hardware has been tightened.

NOTE: An optional stand is available from JET, see *sect. 11.0*.

### 5.5 Assembly

See Figure 5-1 to identify parts.

1. Screw three downfeed handles (F) into hub and tighten. Flat spot on rod accommodates an open or adjustable wrench. **Note:** Handle shafts are already installed into hub on powerfeed models.
2. Slide crank (E) onto shaft of column (see Figure 7-2) and tighten set screw. Make sure set screw seats on flat part of shaft.
3. Thread handle (D) into crank and tighten nut.



4. Slide handwheels (A) onto shafts at front and both ends of table. If needed, tap with rubber mallet to seat handwheels onto shafts. Tighten set screws.
5. Thread handle (D) onto each handwheel and tighten nut.
6. Loosen lock handles/nuts (Q or R, Figure 7-2) and raise head using crank (E) to remove shipping block from table.

## 5.6 Lubrication

The Mill-Drill must be checked for proper lubrication before operating. See *sect.9.3*.

## 6.0 Electrical connections

**⚠WARNING** Electrical connections must be made by a qualified electrician in compliance with all relevant codes. This machine must be properly grounded to help prevent electrical shock and possible fatal injury.

The Mill-Drill is rated at 115/230V power, and is pre-wired for 115 volt. The machine is provided with a plug designed for use on a circuit with a *grounded outlet* that looks like the one pictured in **A**, Figure 6-1.

Before connecting to power source, be sure switch is in *off* position.

It is recommended that the Mill-Drill, *when operated on 115V*, be connected to a dedicated 20 amp circuit with circuit breaker or fuse. When operated *on 230V power*, connect it to a dedicated 15 amp circuit with circuit breaker or fuse. If connected to a circuit protected by fuses, use time delay fuse marked "D".

**NOTE: Local codes take precedence over recommendations.**

### 6.1 GROUNDING INSTRUCTIONS

This machine must be grounded. In the event of a malfunction or breakdown, grounding provides a path of least resistance for electric current to reduce the risk of electric shock. This tool is equipped with an electric cord having an equipment-grounding conductor and a grounding plug. The plug must be plugged into a matching outlet that is properly installed and grounded in accordance with all local codes and ordinances.

Do not modify the plug provided - if it will not fit the outlet, have the proper outlet installed by a qualified electrician.

Improper connection of the equipment-grounding conductor can result in a risk of electric shock. The conductor with insulation having an outer surface that is green with or without yellow stripes is the equipment-grounding conductor. If repair or replacement of the electric cord or plug is

necessary, do not connect the equipment-grounding conductor to a live terminal.

**⚠WARNING** Check with a qualified electrician or service personnel if the grounding instructions are not completely understood, or if in doubt as to whether the tool is properly grounded. Failure to comply may cause serious or fatal injury.

Use only 3-wire extension cords that have 3-prong grounding plugs and 3-pole receptacles that accept the tool's plug.

Repair or replace damaged or worn cord immediately.

*Grounded, cord-connected tools intended for use on a supply circuit having a nominal rating less than 150 volts:*

This tool is intended for use on a circuit that has an outlet that looks like the one illustrated in **A**, Figure 6-1. An adapter, shown in **B** and **C**, may be used to connect this plug to a 2-pole receptacle as shown in **B** if a properly grounded outlet is not available. The temporary adapter should be used only until a properly grounded outlet can be installed by a qualified electrician. The green-colored rigid ear, lug, and the like, extending from the adapter must be connected to a permanent ground such as a properly grounded outlet box. **Note:** *In Canada, the use of a temporary adaptor is not permitted by the Canadian Electrical Code, C22.1.*

*Grounded, cord-connected tools intended for use on a supply circuit having a nominal rating between 150 - 250 volts, inclusive:*

This tool is intended for use on a circuit that has an outlet that looks like the one illustrated in **D**, Figure 6-1. The tool is intended to be used with a grounding plug that looks like the plug illustrated in **D**. Make sure the tool is connected to an outlet having the same configuration as the plug. No adapter is available or should be used with this tool. If the tool must be reconnected for use on a different type of electric circuit, the reconnection should be made by qualified service personnel; and after reconnection, the tool should comply with all local codes and ordinances.

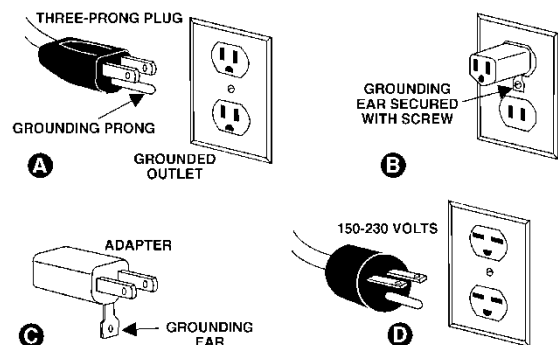

Figure 6-1

## 6.2 Voltage conversion

To convert machine to 230 volt operation:

1. Change incoming power leads according to wiring diagram on inside cover of motor junction box.
2. Replace plug on end of motor cord with a UL/CSA listed plug rated for 230V; or hardwire the machine.

## 6.3 Extension cords

The use of extension cords is discouraged; try to position equipment within reach of the power source. If an extension cord becomes necessary, be sure it is heavy enough to carry the current your product will draw. An undersized cord will cause a drop in line voltage resulting in loss of power and overheating.

Table 2 shows recommended size to use depending on cord length and nameplate ampere rating. If in doubt, use the next heavier gauge. The smaller the gauge number, the heavier the cord.

Ampere Rating		Volts	Total length of cord in feet			
More Than	Not More Than		25	50	100	150
		120	25	50	100	150
		240	50	100	200	300
			AWG			
0	6		18	16	16	14
6	10		18	16	14	12
10	12		16	16	14	12
12	16		14	12	Not Recommended	

Table 2: Extension Cord Recommendations

## 6.4 Overload re-set button

If the Mill-Drill becomes overloaded and motor shuts off, wait for machine to cool down, then push re-set button on motor junction box. Restart machine. If overloading happens frequently, refer to *sect. 10.0, Troubleshooting*.

## 7.0 Adjustments

**⚠WARNING** Disconnect machine from power source before making adjustments, unless indicated otherwise.

### 7.1 Removing and installing arbors

1. Disconnect machine from power source.
2. Remove spindle cap to expose drawbar (Figure 7-1)
3. Loosen drawbar with provided socket wrench counterclockwise 2 or 3 full turns.

4. Tap drawbar head with rubber mallet to dislodge arbor.

**⚠CAUTION** Do not loosen drawbar more than 3 or 4 turns before hitting with rubber mallet. Damage to drawbar threads may occur.

5. Grasp arbor with one hand while loosening drawbar with the other. Continue to loosen drawbar until arbor can be withdrawn from spindle. Wipe out spindle with clean, dry rag.
6. Wipe new arbor with clean, dry rag and place arbor into spindle. Thread drawbar into arbor from above. Tighten drawbar with wrench. Do not overtighten.

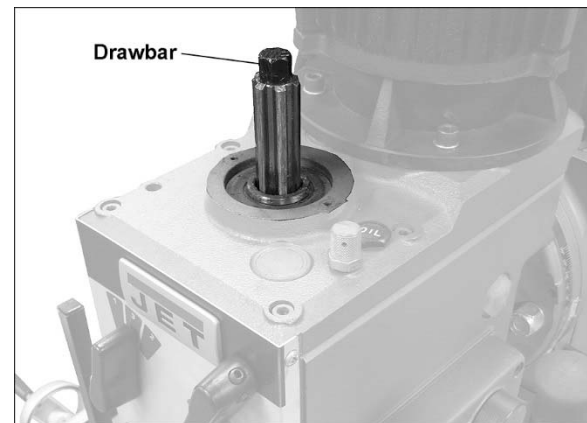

Figure 7-1

## 7.2 Head adjustments

See Figure 7-2.

### 7.2.1 Head elevation

Loosen two hex nuts (Q, JMD-40) or handles (R, JMD-45). Turn crank handle (E) clockwise to raise head on column, counterclockwise to lower head. Always tighten nuts/handles securely before milling or drilling operations.

### 7.2.2 Head rotation (JMD-40GH/GHPF)

Applicable only to JMD-40 models. Loosen two lock nuts (Q) with 24mm wrench, and rotate head around column. Make sure rack moves with head without binding. Retighten both lock nuts (Q) securely.

### 7.2.3 Head swivel

1. To swivel head up to 90° left or 30° right, loosen lock nut (S) on each side, and remove locating pin (T).
2. Swivel head to desired angle on scale. Retighten *both* lock nuts.
3. When returning head to vertical position (0-deg.), re-insert locating pin (T) and securely tighten both lock nuts (S).

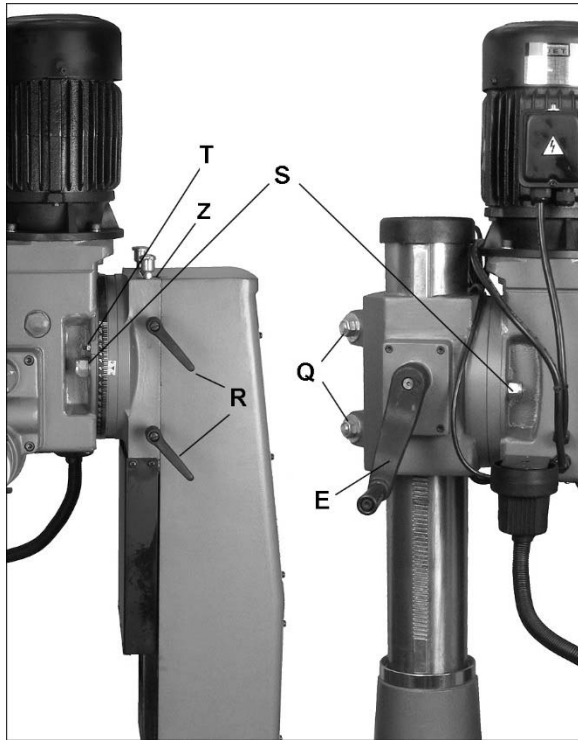

Figure 7-2: head adjustments

### 7.3 Table adjustments

See Figure 7-3.

For X-axis longitudinal feed, loosen table locks ( $L_1$ ) and use side handwheel ( $L_2$ ). The cross feed table locks ( $C_1$ ) should be kept tight.

For Y-axis cross feed, loosen table locks ( $C_1$ ) and use front handwheel ( $C_2$ ). The longitudinal feed table locks ( $L_1$ ) should be kept tight.

The scales can be adjusted by loosening screw ( $T_1$ ) and rotating scale to align with indicator.

The stops ( $T_2$ ) can be adjusted to any point along the longitudinal axis. Retighten screws after positioning.

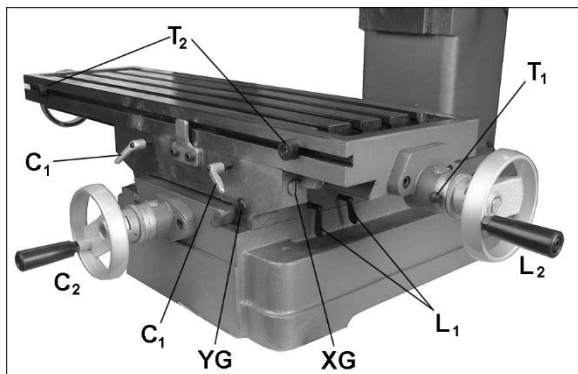

Figure 7-3: table and gib adjustments

## 7.4 Gib adjustments

### 7.4.1 Table gibs

See Figure 7-3.

Gibs have been properly adjusted by the manufacturer. After a period of time, however, movement of the table over the ways will cause normal wear and some “play” between components. To adjust gibs to eliminate this play, proceed as follows.

1. The X-axis gib adjustment screw (XG, Figure 7-3) is found on right side of saddle beneath table. The Y-axis gib adjustment screw (YG, Figure 7-3) is found to the right on the table face.
2. Turn each screw slightly clockwise to tighten. Turn table handwheels to check tension; slight drag should be felt during movement.
3. Re-adjust as required.

### 7.4.2 Column gib (JMD-45 series only)

A Z-axis gib adjustment screw is located atop the square column near oil cup (see Z, Figure 7-2). Follow same principle as described under sect. 7.4.1. Slight drag should be felt when turning crank handle.

## 7.5 Spindle return

The spindle return is pre-set by the manufacturer and should not require adjustment. If spring tension becomes a future issue due to wear, proceed as follows.

See Figure 7-4.

1. Loosen knob (A) just enough to rotate spring cap (B) past pin (C) and settle it on the next notch. **DO NOT** remove spring cap or allow it to rotate freely in your hand, or spring may unwind.
2. Rotate spring cap *clockwise* to decrease spring tension; *counterclockwise* to increase.
3. Tighten knob (A).

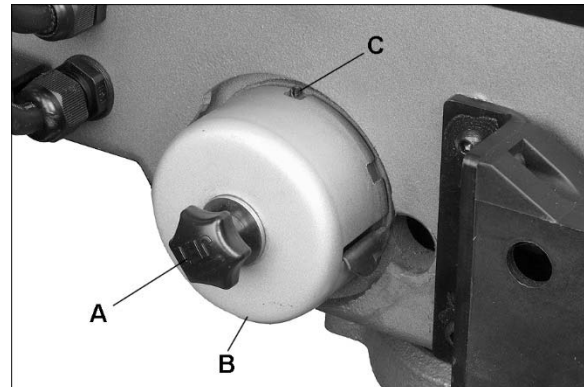

Figure 7-4: spindle return spring adjustment

## 8.0 Operation

### 8.1 Operating controls

Refer to Figure 8-1 (non-powerfeed models) or Figure 8-2 (powerfeed models).

**Depth stop and scale.** *Non-powerfeed models:* Turn knurled knob (A<sub>1</sub>) until pointer (A<sub>2</sub>) reaches desired mark on scale. *Powerfeed models:* Turn scale (A<sub>3</sub>) to desired depth, and tighten lock handle (A<sub>4</sub>).

**Downfeed handle (B).** Counterclockwise movement advances quill toward table. When released, return spring retracts quill. **CAUTION:** Handle will spring back if released, and will rotate during retraction.

**Fine feed engagement knob (C).** *Non-powerfeed models only.* Tighten knob to engage fine feed handwheel (D). Loosen knob to use downfeed handle.

**Fine feed handwheel (D).** *Non-powerfeed models:* To engage, tighten knob (C). *Powerfeed models:* To engage, turn downfeed dial (H) to zero, loosen knob (J), and push feed handle (B) outward.

**Fwd/Off/Rev switch (E).** Activates spindle rotation and selects rotation direction.

**Spindle lock handle (F).** Turn clockwise to lock spindle in position, counterclockwise to release.

**Speed Levers (G).** Select speed according to chart on control plate. A similar chart is shown as Table 3. While moving speed levers, turn spindle by hand to ensure proper gear engagement.

**CAUTION** Turn switch to OFF before changing speed. Failure to comply may damage gear mechanism.







RPM	Levers	
65	 1	 = black  = red
130	 2	
220	 3	
480	 1	
925	 2	
1550	 3	

Table 3: speed selection

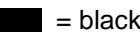
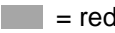
**Downfeed dial (H).** *Powerfeed models only.* Select among three feed rates. Must be set to zero when using fine feed handwheel.

**Powerfeed disengagement knob (J).** *Powerfeed models only.* Tighten to prevent powerfeed engagement and fine feed engagement. Loosen to allow downfeed handles (B) to be pushed outward into powerfeed and fine feed position.

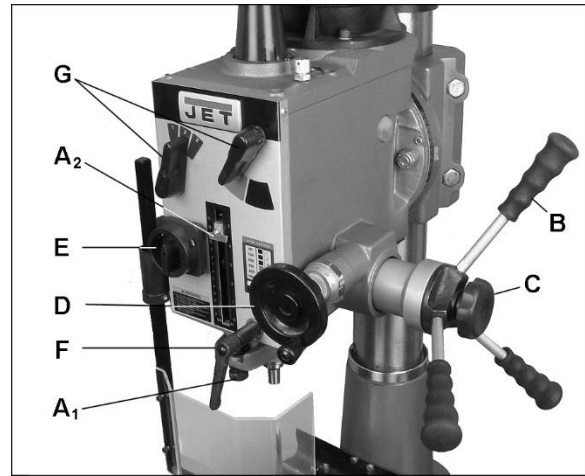

Figure 8-1: operating controls (non-PF models)

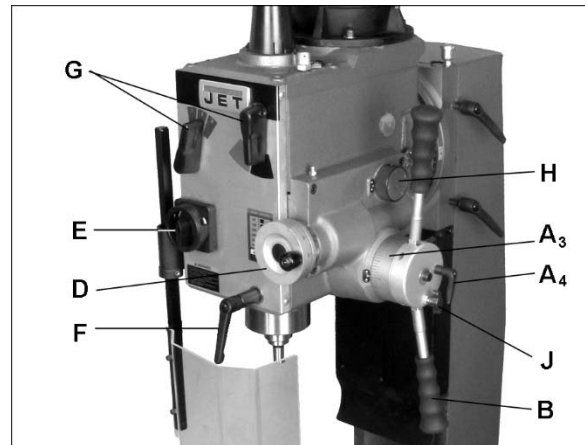

Figure 8-2: operating controls (PF models)

### 8.2 Powerfeed operation (models 40GHPF and 45GHPF only)

**CAUTION** Turn machine OFF before selecting speed and initial powerfeed settings. Failure to comply may damage gear mechanism.

See Figure 8-2.

1. Disengage spindle lock (F).
2. Select appropriate spindle speed (G).
3. Select downfeed rate (H).
4. Loosen handle (A<sub>4</sub>) and rotate collar (A<sub>3</sub>) counterclockwise to desired depth on scale.  
OR... lower spindle to desired depth and set collar to zero on scale.
5. Tighten handle (A<sub>4</sub>) to secure setting.
6. Loosen powerfeed disengagement knob (J).
7. Turn on machine and pull downfeed handle (B) away from column to activate power downfeed.
8. Once downfeed has reached pre-set depth, the trip will release and spindle will retract.

9. To stop feed before cycle has ended, push handle (B) toward head.

NOTE: Set downfeed dial (H) to zero when not using powerfeed.

### 8.3 Manual coarse feed

**Non-powerfeed models** (Figure 8-1):

1. Disengage spindle lock (F) and loosen lock knob (C).
2. Select spindle speed (G).
3. Set drill depth (A<sub>1</sub>/A<sub>2</sub>).
4. Turn on machine and engage workpiece using downfeed handle (B).

**Powerfeed models** (Figure 8-2):

1. Disengage spindle lock (F).
2. Set feed rate to "0" on dial (H).
3. Select spindle speed (G).
4. Set drill depth (A<sub>3</sub>/A<sub>4</sub>).
5. Tighten thumb screw (J) to prevent auto downfeed engagement.
6. Turn on machine and engage workpiece using downfeed handle (B).

### 8.4 Manual fine feed

**Non-powerfeed models** (Figure 8-1):

1. Disengage spindle lock (F).
2. Tighten lock knob (C).
3. Select spindle speed (G).
4. Rotate fine feed handwheel (D). Scale is 0.001 inch increments.

**Powerfeed models** (Figure 8-2):

1. Disengage spindle lock (F).
2. Set feed rate to "0" on dial (H).
3. Set depth scale (A<sub>3</sub>/A<sub>4</sub>) to desired stop; or set it to exceed the desired depth to prevent premature stopping of feed.
4. Select spindle speed (G).
5. Pull handles (B) into powerfeed position.
6. Turn fine feed handwheel (D) to accomplish operation. Fine feed scale is 0.001 inch graduations. If depth reaches pre-set stop, fine feed will disengage and spindle will retract. To disengage fine feed at any time, push handle (B) toward head.

### 8.5 Basic milling procedure

The Mill-Drill is provided with a face mill cutter with tungsten carbide inserts. Install cutter onto mill arbor, and secure with socket cap screw and washer

(N and O, Figure 5-1). Install arbor into spindle using procedure in *sect. 7.1*.

For best results, all milling operations should be performed with cutter raised as close to head assembly as possible.

1. Adjust depth stop to highest position.
2. Engage fine feed handwheel, and turn it to set milling height.
3. Tighten spindle lock (F, Figures 8-1,8-2) at desired height.
4. See *sect. 7-3* for table movements.

**⚠ WARNING** Lock spindle in position before attempting milling operations.

## 9.0 User-maintenance

**⚠ WARNING** Always disconnect power to machine before performing maintenance. Failure to do this may result in serious personal injury.

### 9.1 General maintenance

1. After each use, wipe down machine with a clean rag and apply light coat of oil to exposed metal surfaces.
2. Periodically check for backlash, or "play", in table and head movements. If handles or handwheels are turned an appreciable amount before they seem to engage, or there is a looseness in table or head movements, make adjustments using gib screws. See *sect. 7.4*.
3. Keep table and ways clean and free of debris. Use a brush to clear shavings, not bare hands.
4. Make sure machine remains properly lubricated. See *sect. 9.3*.

### 9.2 Additional servicing

Any additional servicing should be performed by authorized service personnel.

### 9.3 Lubrication

Note: Spindle bearings are sealed and do not require further lubrication.

Location (see Figure 13-1)	Applicable model	Recommended lubricant (an equivalent may be used)	Frequency
Ball oiler, handwheels (L <sub>1</sub> )	all	Mobil DTE® Oil Heavy Medium	Once daily
Ball oiler, front of table (L <sub>2</sub> )	all	Mobil DTE® Oil Heavy Medium	Once daily
Ball oiler, crank handle (L <sub>3</sub> )	JMD-40	Mobil DTE® Oil Heavy Medium	Once daily
Ball oiler for powerfeed (L <sub>4</sub> )	JMD-45	Mobil DTE® Oil Heavy Medium	Once daily
Ways (L <sub>5</sub> )	all	Mobil DTE® Oil Heavy Medium	Once daily (move table along both axes to distribute oil)
Rack (L <sub>6</sub> )	JMD-40	Mobilith® AW2	As needed (especially if head is difficult to raise)
Column (L <sub>7</sub> )	JMD-40	Mobil DTE® Oil Heavy Medium	As needed
Oil cups (L <sub>8</sub> )	JMD-45	Mobil DTE® Oil Heavy Medium	Periodically check sight glass (L <sub>88</sub> ), top off as needed
Oil fill hole for gearbox (L <sub>9</sub> )	all	Mobil DTE® Oil Heavy Medium	Periodically check sight glass; top off to half-way mark. Completely drain and refill once a year (drain plug beneath head)
Cross & Longitudinal leadscrews (L <sub>10</sub> ) (move table forward and remove way cover to access cross leadscrew)	all	Mobilith® AW2	As needed (especially if handwheels do not turn smoothly)
Gear and rack (L <sub>11</sub> ) (remove upper back panel)	JMD-45	Mobilith® AW2	As needed (especially if head is difficult to raise)
Return spring (L <sub>12</sub> ) (loosen cover-do NOT remove-and apply with squirt can or brush)	All	SAE 20	Once annually

Table 4

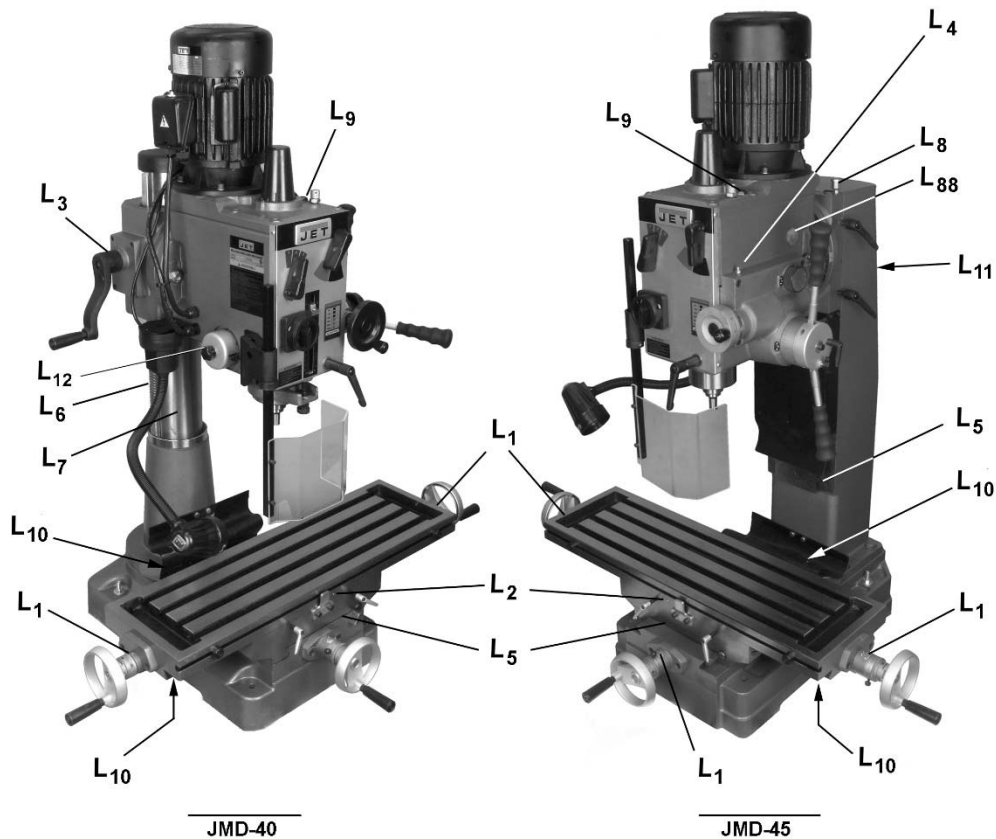

Figure 9-1: lubrication areas

## 10.0 Troubleshooting JMD-40GH/45GH series Mill-Drills

Symptom	Possible Cause	Correction*
Motor will not start.	Low voltage.	Check power line for proper voltage.
	Open circuit in motor or loose connection.	Inspect all lead connections on motor for loose or open connections.
	Overload has tripped.	Press reset button on junction box, and retry.
	Switch failure.	Inspect switch, replace if needed.
Motor will not start: fuses blow or circuit breakers trip.	Short circuit in line cord or plug.	Inspect cord or plug for damaged insulation and shorted wires.
	Short circuit in motor or loose connections.	Inspect all connections on motor for loose or shorted terminals or worn insulation.
	Incorrect fuses or circuit breakers in power line.	Install correct fuses or circuit breakers.
Motor overheats.	Motor overloaded.	Decrease feed pressure to reduce load on motor.
	Air circulation through motor is restricted.	Clean motor fan with compressed air to restore normal air circulation.
	Prolonged operation at higher speeds.	Allow machine to cool.
	Overload relay failure.	Replace relay.
	Motor failure.	Repair or replace motor.
Motor stalls, or doesn't build to normal operating speed.	Motor overloaded.	Reduce feed rate.
	Dull drill bit or mill cutter.	Keep tools sharp.
	Short circuit in motor or loose connections.	Inspect connections on motor for loose or shorted terminals or worn insulation.
	Low voltage.	Correct the low voltage conditions.
	Incorrect fuses or circuit breakers in power line.	Install correct fuses or circuit breakers.
	Motor fault.	Repair or replace motor.
Spindle turns, but with loss of power.	Applying too much downfeed pressure.	Slow downfeed.
	Low voltage.	Correct the low voltage conditions.
	Motor fault.	Repair or replace motor.
Spindle/bearing runs hot.	Prolonged operation at higher speeds.	Allow machine to cool.
	Insufficient spindle lubrication.	Make sure machine is properly lubricated.
Poor cut performance.	Dull bit or cutting tool.	Sharpen or replace.
	Drill chuck loose	Secure chuck in spindle.
	Workpiece not secured to table.	Tighten down workpiece. Use proper vise or jig for irregularly shaped pieces.
	Arbor not secured in spindle.	Adjust tightness with drawbar.
	Spindle runout or loosening due to bearing misadjustment or failure.	Inspect spindle elements, such as bearings and lock nuts; adjust or replace.
Fine feed not smooth, or won't engage properly.	Fine feed handwheel loose.	Tighten set screw.
	Non-powerfeed models: damaged spring between worm gear and locking knob.	Replace spring.
	Improper worm gear engagement.	Replace worm gear elements as needed.

Symptom	Possible Cause	Correction*
Excessive vibration or noise.	Loose motor fan.	Inspect and tighten.
	Spindle improperly lubricated.	Maintain proper machine lubrication.
	Spindle runout or loosening due to bearing misadjustment or failure.	Inspect spindle elements, such as bearings and lock nuts; adjust or replace.
	Motor imbalance.	Repair or replace motor.
Drill or cutter overheats or burns workpiece.	Dull cutting tool.	Sharpen or replace.
	Insufficient feed rate.	Increase feed rate. Consult machinery handbook for proper speeds and feed rates for specific materials.
	Excessive spindle speed.	Reduce speed. Consult machinery handbook for proper speeds and feed rates for specific materials.
	Tool rotation incorrect.	Reverse rotation.
	Chips not clearing.	Adjust speed or feed rate to allow proper clearing.
	Failure to use cutting lubricant.	Use proper lubricant for material being cut.
Drill bit wanders.	No drill spot.	Center punch or center drill workpiece.
	Improper geometry of cutting edges.	Regrind drill bit or replace.
	Spindle or quill loose, or play in bearings.	Inspect and adjust.
Excessive wobble/runout in drill.	Improper chucking of bit.	Properly reinsert drill bit in chuck.
	Drill bent.	Replace.
	Play in spindle bearings	Inspect and adjust.

Table 5

**\*Warning:** Some corrections may require a qualified electrician.

## 11.0 Optional accessories

An optional enclosed stand (p/n 350045) is available for your JET Mill-Drill Machine. Contact your dealer or visit our website for more information.



Figure 9-1: optional stand

## 12.0 Replacement Parts

Replacement parts are listed on the following pages. To order parts or reach our service department, call 1-800-274-6848 Monday through Friday, 8:00 a.m. to 5:00 p.m. CST. Having the Model Number and Serial Number of your machine available when you call will allow us to serve you quickly and accurately.

Non-proprietary parts, such as fasteners, can be found at local hardware stores, or may be ordered from JET. Some parts are shown for reference only, and may not be available individually.



# 12.1.1 JMD-40GH,-40GHPF Table, Base, and Column Assembly – Exploded View

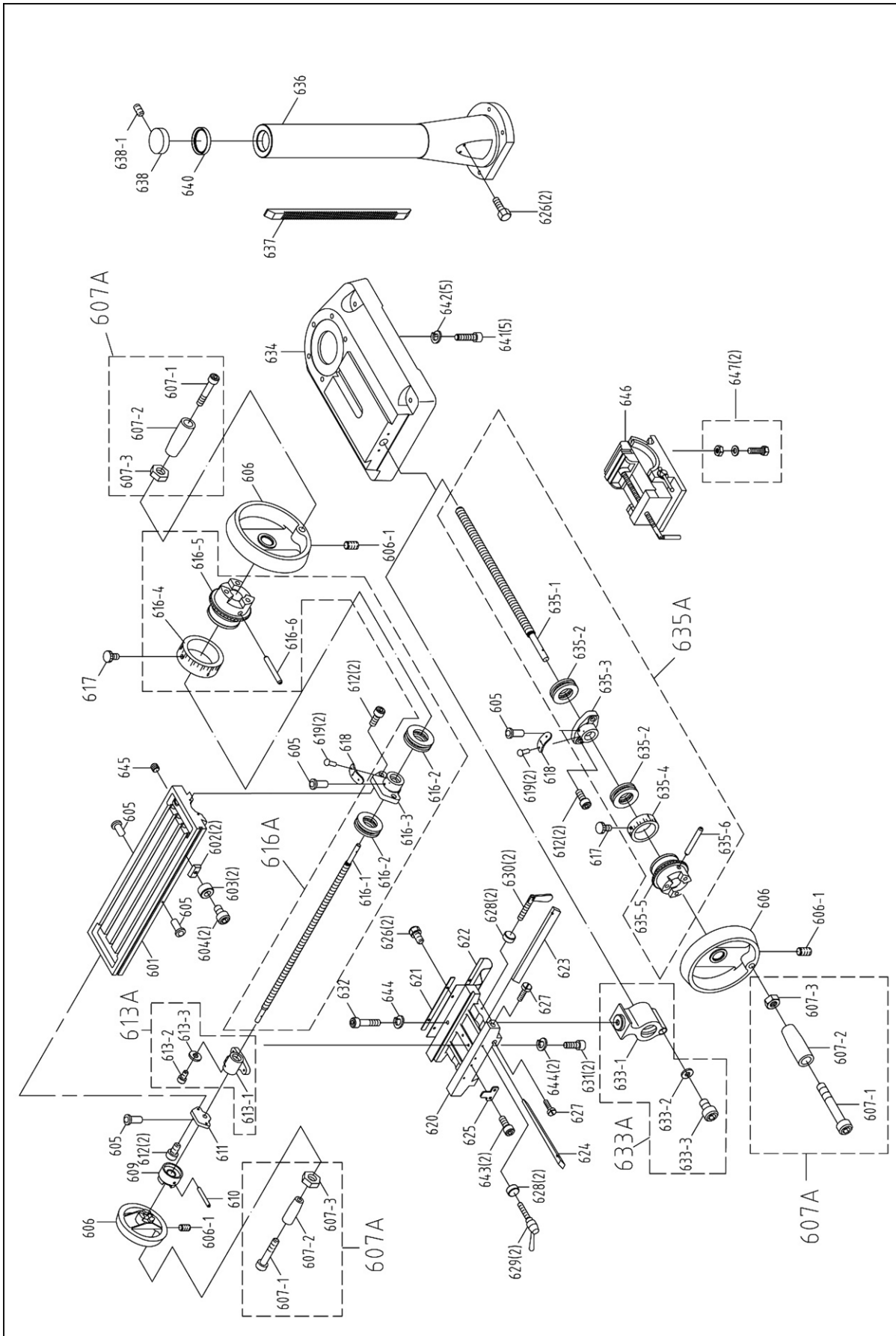

## 12.1.2 JMD-40GH,-40GHPF Table, Base, and Column Assembly – Parts List

Index No.	Part No.	Description	Size	Qty
601	JMD18-228G	Table	31L	1
602	JMD18-229	Fixed T-Block		2
603	JMD18-230	Stop Ring		2
604	TS-0207021	Hex Socket Head Cap Screw	1/4"-20x1/2"	2
605	JMD18-368	Ball Oiler	1/4"	5
606	JMD18-201	Table Handwheel		3
606-1	TS-0267041	Set Screw	1/4"-20x3/8"	3
607A	JMD18-201A	Handle Assembly (#607-1 thru 607-3)		3
607-1	JMD18-201-1	Hex Socket Head Cap Screw (RE: JMD18-201-2)	3/8"-16x16	3
607-2	JMD18-201-2	Handle		3
607-3	TS-0561031	Hex Nut	3/8"-16	3
609	JMD18-220	Table Clutch		1
610	JMD18-366	Spring Pin	5x38L mm	1
611	JMD18-222	Left Flange		1
612	TS-0208061	Hex Socket Head Cap Screw	5/16"-18x1"	6
613A	JMD18-223A	Table Nut Set (#613-1 thru 613-3)		1
613-1	JMD18-223	Table Nut	TM23.7-10	1
613-2	TS-1502041	Hex Socket Head Cap Screw	M5-0.8x16	1
613-3	TS-1550031	Flat Washer	M5	1
616A	JMD18-224A	Table Screw Assembly (#616-1 thru 616-6)		1
616-1	JMD18-224	Table Lead Screw		1
616-2	BB-51103	Thrust Bearing	51103	2
616-3	JMD18-226	Right Flange		1
616-4	JMD18-202-1	Graduated Dial		1
616-5	JMD18-202	Dial Clutch		1
616-6	JMD18-366	Spring Pin	5x38L mm	1
617	JMD18N-617	Link Screw		2
618	JMD18-121	Indicator Plate		2
619	JMD18-204-2	Rivet	2mm	4
620	JMD18-216G	Center Base	31L	1
621	JMD18-219	Anti-Dust Plate		1
622	JMD18-217	Anti-Dust Plate Assembly		1
623	JMD18-227	Gib Strip	31L	1
624	JMD18-207	Gib Strip	31L	1
625	JMD18-214	Fixed Block		1
626	TS-0051011	Hex Cap Screw	5/16"-18x1/2"	4
627	JMD18-212	Gib Strip Bolt		2
628	JMD18N-628	Bushing		4
629	JMD18-213-1	Locking Handle		2
630	JMD18-213	Leaf Screw		2
631	TS-0208061	Hex Socket Head Cap Screw	5/16"-18x1"	2
632	TS-0051101	Hex Socket Head Cap Screw	5/16"-18x2-1/4"	1
633A	JMD18-215A	ACME Nut Assembly (#633-1 thru 633-3)		1
633-1	JMD18-215	ACME Nut	TM23	1
633-2	TS-1550031	Flat Washer	M5	1
633-3	TS-1502041	Hex Socket Head Cap Screw	M5x16	1
634	JMD18N-634G	Base		1
635A	JMD18-205A	ACME Nut Assembly (#63-1 thru 635-6)		1
635-1	JMD18-205	Cross Lead Screw	TM23	1
635-2	BB-51103	Thrust Bearing	51103	2
635-3	JMD18-204	Square Flange		1
635-4	JMD18-202-1	Graduated Dial		1
635-5	JMD18-202	Dial Clutch		1
635-6	JMD18-366	Spring Pin	5x38 mm	1
636	JMD18N-636G	Column Base		1
637	JMD18N-637	Rack	600.5L	1
638	JMD18-211	Column Cap		1
638-1	TS-0270021	Set Screw	5/16"-18x5/16"	1
640	JMD18-209	Column Flange Ring		1
641	F004999	Hex Socket Head Cap Screw	5/8"-11x2-1/2"	5

Index No.	Part No.	Description	Size	Qty
642	TS-0720131	Lock Washer	5/8"	5
643	TS-0208022	Hex Socket Head Cap Screw	5/16"-24x1/2"	2
644	JMD18N-644	Lock Washer	5/16"	3
645	JMD18N-645	Plug	PT1/4"x3/8"	1
646	365534	Angle Vise		1
647	365534-01	Hardware Package (2 Bolts, 2 Nuts, 2 Washers)		1
	JMD40GH-AP	Accessory Package (not shown) *		1

\* Contents of JMD40GH-AP Accessory Package:

JMD18-020	Cutter Arbor		1
JMD18-022	Handle		4
JMD18-039	Handle Rod		3
JMD18-040	Knob		3
JMD18-050	Lock Handle		1
561704	Drill Chuck w/Chuck Key	JT6, 1/2" (13mm)	1
JMD18-086	Face Mill Cutter Assembly	3" (74mm)	1
JMD18-021	Chuck Arbor (Installed)		1
365534	Angle Vise		1
JMD18-058	Handle Crank		1
JMD18-201	Wheel		3
TS-152704	Hex Wrench	3mm	1
TS-152705	Hex Wrench	4mm	1
TS-152706	Hex Wrench	5mm	1
TS-0209051	Hex Socket Cap Screw	3/8"-16x1"	1
TS-0680041	Flat Washer	3/8"	1
365534-01	Hardware Package (2 Bolts, 2 Nuts, 2 Washers)		1
JMD40GH-PW	Plum Wrench		1

12.2.1 JMD-40GH,-45GH (non-powerfeed) Gear Head Assembly – Exploded View

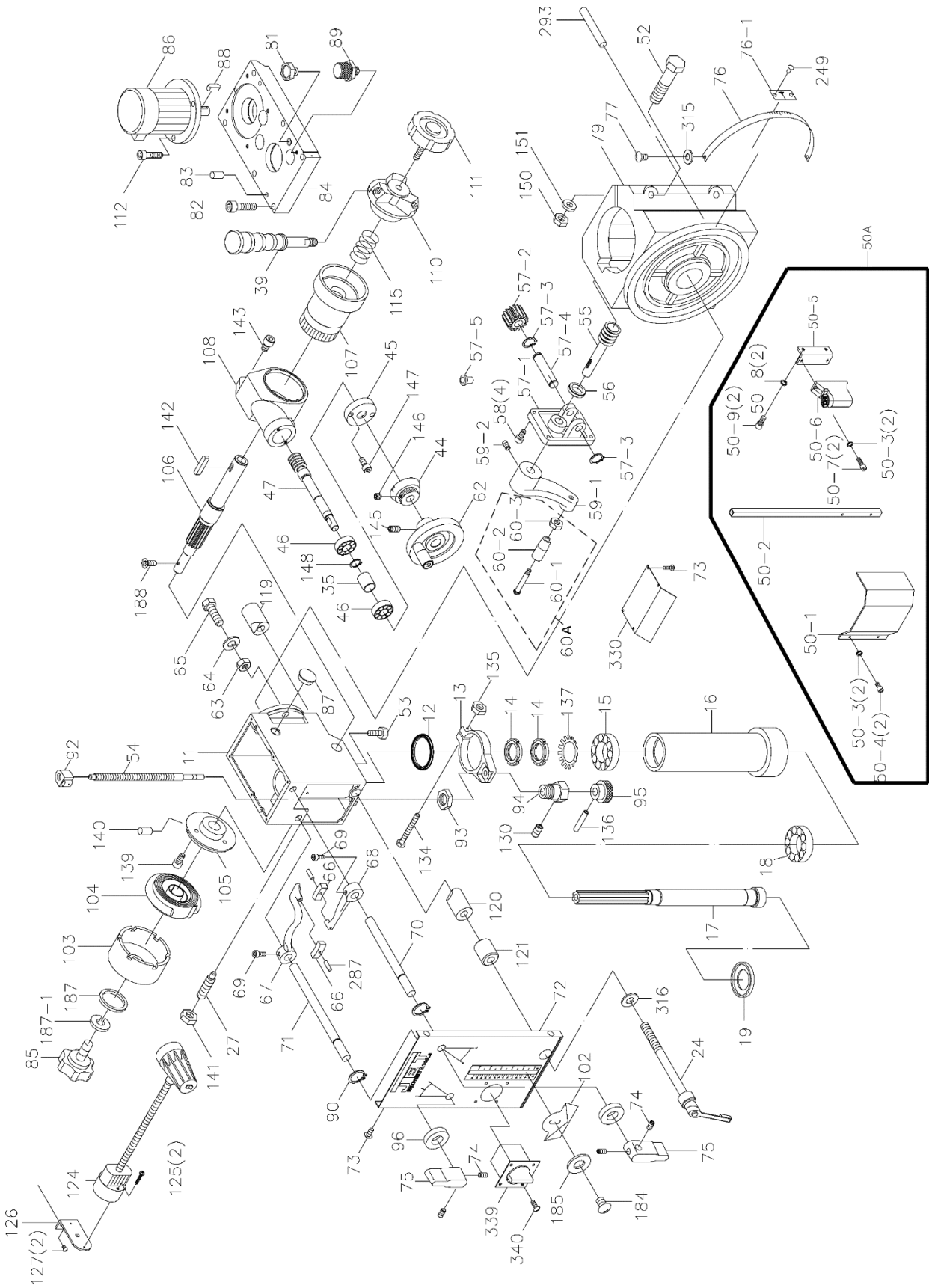

## 12.2.2 JMD-40GH,-45GH (non-powerfeed) Gear Head Assembly – Parts List

Index No.	Part No.	Description	Size	Qty
11	2401011G	Head Casting		1
12	6112	Rubber Gasket		1
13	6513	Feed Base		1
14	6114	Lock Nut		2
15	BB-30206	Taper Roller Bearing	30206	1
16	6116-R8	Quill	R8	1
17	6117-R8	Spindle Shaft	R8	1
18	BB-30207	Taper Roller Bearing	30207	1
19	6119	Bearing Cap		1
24	2421003	Handle Rod Assembly		1
27	6127	Screw Key		1
35	6135	Bearing Spacer		1
39	6139N	Handle Rod		3
44	6144	Micro Adjusting Indicator		1
45	6145	Worm Cover		1
46	BB-6202Z	Ball Bearing	6202Z	2
47	6147	Worm Shaft		1
50-A	GHD20-50-A	Chuck Guard Assembly (#50-1 thru 50-9)		1
50-1	JMD18-125-1	Chuck Guard and Support Rod		1
50-2	JMD18-125-2	Support Rod (RE: JMD18-125-1)		1
50-3	TS-2361051	Lock Washer	M5	4
50-4	TS-1502021	Hex Socket Head Cap Screw	M5 x 10	2
50-5	GHD20-50-5	Chuck Guard Bracket		1
50-6	JMD18-125-5	Rotary Support Base		1
50-7	JMD18-125-6	Hex Socket Head Cap Screw	M5x15L	2
50-8	TS-1551041	Lock Washer	M6	2
50-9	6286490	Hex Socket Head Cap Screw	M6x15L	2
52	TS-0071141	Hex Cap Screw	5/8"-11 x 5-1/2"	2
53	GHD20-53	Oil Plug		1
54	GHD20-54	Threaded Rod		1
55	JMD40GH-55	Worm Shaft		1
56	JMD40GH-56	O-Ring		1
57-1	JMD40GH-57-1	Bracket		1
57-2	JMD40GH-57-2	Worm Gear		1
57-3	F006042	C-Ring, External	S14	2
57-4	JMD40GH-57-4	Shaft		1
57-5	JMD40GH-57-5	Ball Oiler		1
58	TS-0207041	Hex Socket Head Cap Screw	1/4"-20x3/4"	4
59-1	JMD40GH-59-1	Crank		1
59-2	TS-0271052	Set Screw	3/8"-24x1/2"	1
60A	JMD18-201A	Handle Assembly (#60-1 thru 60-3)		1
60-1	TS-0561031	Hex Socket Head Cap Screw	3/8"-16x16UNC	1
60-2	JMD18-201-2	Handle		1
60-3	TS-0561031	Hex Nut	3/8"-16	1
62	6142-2	Handwheel		1
63	F001600	Full Nylon Insert Lock Nut	5/8"-11	3
64	TS-0680081	Flat Washer	5/8"	2
65	F008242	Hex Cap Screw	5/8"-11 x 2-1/4"	3
66	2401066	Gear Lever Bracket		2
67	2401067	Gear Lever (Left)		1
68	2401068	Gear Lever (Right)		1
69	GHD20-69	Screw	1/4" x 1/2"	2
70	2401070	Lever Shaft (Right)		1
71	2401071	Lever Shaft (Left)		1
72	JMD40GH-72	Name Plate		1
	JET-92	JET Logo (not shown)	92x38MM	1
73	GHD20-73	Phillips Head Screw	3/16" x 3/8"	8
74	TS-0267021	Set Screw	1/4"-20 x 1/4"	8
75	2401075	Speed Lever		2
76	2401076	Scale		1

Index No.	Part No.	Description	Size	Qty
76-1	2401076-1	Pointer		1
77	GHD20-77	Screw		2
79	2412001G	Casting		1
81	GHD20-81	Oil Plug		1
82	TS-0209031	Hex Socket Cap Screw	3/8"-16 x 3/4"	6
83	GHD20-83	Miter Pin		2
84	2401084G	Cover		1
85	6185	Lock Knob		1
86	JMD40GH-86	Motor	1.5HP 1PH 115/230V	1
	JMD40GH-86MF	Motor Fan		1
	JMD40GH-86MFC	Motor Fan Cover		1
	JMD40GH-86SC	Start Capacitor	400MFD 125VAC	1
	JMD40GH-86CC	Capacitor Cover		1
	JMD40GH-86JB	Junction Box		1
	JMD40GH-86JBC	Junction Box Cover		1
87	GHD20-87	Oil Sight Glass		1
88	GHD20-88	Key	6 x 6 x 30mm	1
89	GHD20-89	Brass Fitting		1
90	6286478	C-Ring, External	S12	2
92	6192	Block		1
93	6193	Nut		1
94	6194	Support Base		1
95	6195	Knurled Knob Assembly		1
96	GHD20-96	Oil Seal		2
102	61102	Limit Plate		1
103	61103S	Spring and Cover (includes #104)		1
104	61104	Spring (RE:61103S)		1
105	61105	Spring Base		1
106	61106	Pinion Shaft		1
107	61107	Worm Gear		1
108	61108G	Feed Cover		1
110	61110	Spring Base		1
111	6138	Lock Bolt w/ Knob		1
112	TS-0209051	Hex Socket Head Cap Screw	3/8"-16 x 1"	3
115	61115	Compression Spring		1
119	6126-1	Collar (threaded)		1
120	6125-1	Collar Nut		1
121	6125-2	Collar		1
124	JMD40GH-124	Lamp Assembly	110V	1
125	TS-2284352	Phillips Pan Head Machine Screw	M4-0.7x35L	2
126	GHD20-126	Lamp Base		1
127	TS-1503031	Hex Socket Head Cap Screw	M6-1.0 x 12L	2
130	TS-1501021	Hex Socket Head Cap Screw	M4-0.7 x 8	1
134	TS-0050091	Hex Cap Screw	1/4"-20 x 2"	1
135	TS-0561011	Hex Nut	1/4"-20	1
136	F012072	Roll Pin	Ø4x20L	1
137	GHD20-137	Star Washer, Ext. Tooth	M30	1
139	GHD20-139	Screw	3/16" x 3/4"	3
140	GHD20-140	Spring Pin	Ø3x12L	1
141	TS-0561031	Hex Nut	3/8"-16	1
142	GHD20-142	Double Rd. Hd. Key	7 x 7 x 20 mm	1
143	TS-0208021	Hex Socket Head Cap Screw	5/16"-18 x 1/2"	2
145	TS-0270021	Set Screw	5/16"-18x 5/16"	1
146	TS-0267021	Set Screw	1/4"-20 x 1/4"	1
147	GHD20-147	Hex Socket Head Cap Screw	3/16" x 7/16"	2
148	GHD20-148	C-Ring, External	S15	1
150	TS-0561071	Hex Nut	5/8"-11	2
151	TS-0680081	Flat Washer	5/8"	2
184	F000197	Phillips Pan Hd Machine Screw	#8-32 x 1/4"	1
185	GHD20-185	Flat Washer	1/4"	1
187	TS-0680021	Flat Washer	1/4"	1
187-1	TS-0720071	Lock Washer	1/4"	1

Index No.	Part No.	Description	Size	Qty
188	GHD20-188	Screw	3/16" x 3/8"	1
249	GHD20-249	Rivet		2
287	GHD20-287	Spring Pin	Ø4x16Lmm	2
293	HP309	Taper Pin	M6xØ7 (1:48)	1
315	TS-0680011	Flat Washer	3/16"	2
316	GHD20-374	Flat Washer	1/2"x7/8"x2"	1
330	2401085	Dust Plate		1
339	JMD40GH-339	For/Rev Switch		1
340	GHD20-340	Screw		2
341	JMD40GH-341	Motor Cord (not shown)	14AWGx5C 300V	1
342	JMD40GH-342	Power Cord (not shown)	.3x3.31mm <sup>2</sup> 12AWG, 5-20P	1
	LM000286	Warning Label, Mill-Drills (not shown)		1

12.3.1 JMD-40GH,-45GH (non-powerfeed) Gears Assembly – Exploded View

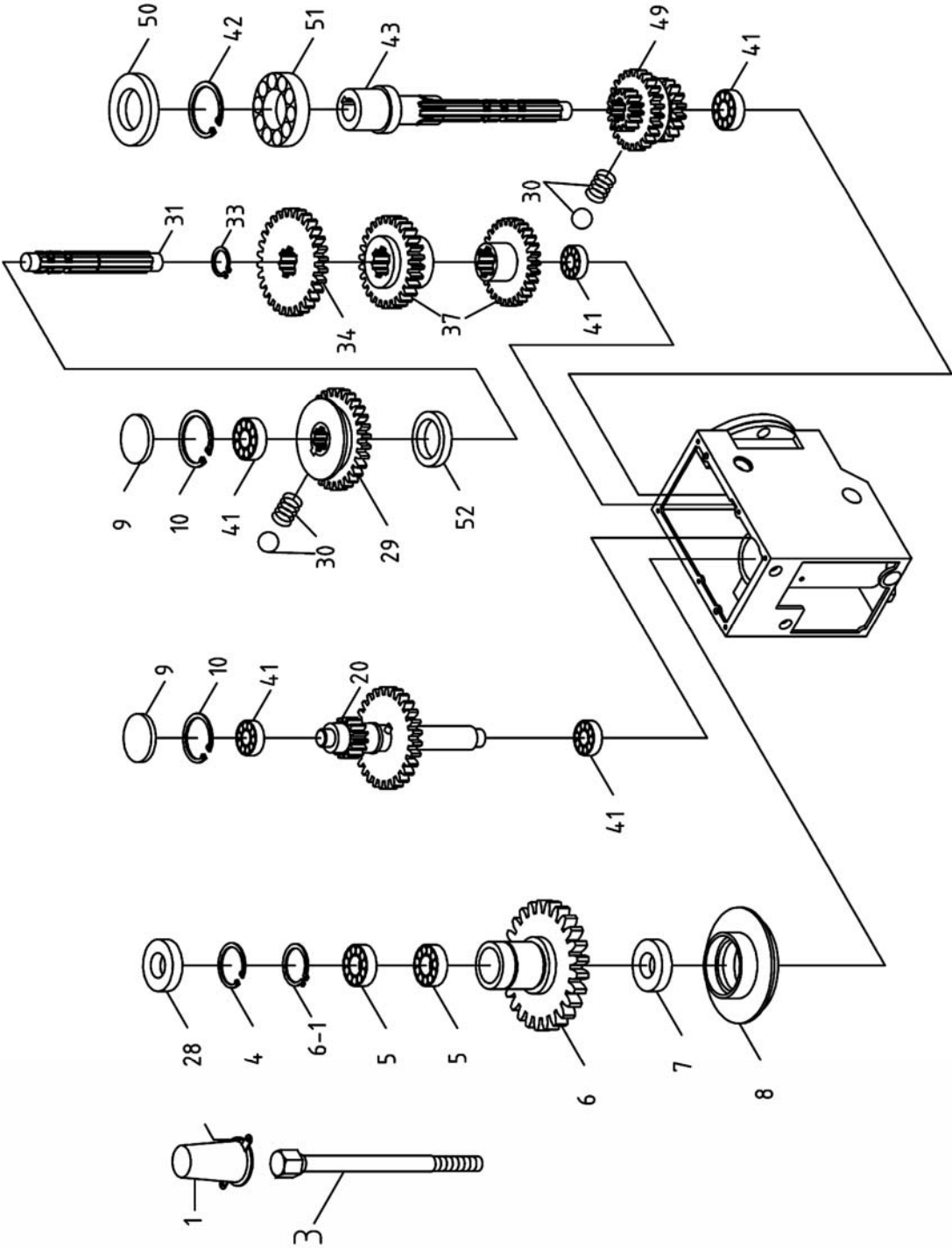



### 12.3.2 JMD-40GH,-45GH (non-powerfeed) Gears Assembly – Parts List

Index No.	Part No.	Description	Size	Qty
1	2401001-2	Main Shaft Cover		1
3	JMD40GH-03	Draw Bar	7/16"	1
4	GHD20-4	Retainer Ring, Internal	R68	1
5	BB-6008ZZ	Ball Bearing	6008ZZ	2
6	2401006	Idle Gear	53T	1
6-1	F006055	C-Ring, External	S40	1
7	GHD20-7	Oil Seal		1
8	2401008	Oil Seal Ring		1
9	GHD20-9	Dust Cover		2
10	GHD20-10	C-Ring, External	S17	2
20	2401020A	Gear Shaft Assembly	15/41T	1
28	GHD20-28	Oil Seal		1
29	2401029N	Idle Gear	42/16T	1
30	GHD20-30	Steel Ball w/ Spring	5/16"	3
31	2401031	Pinion Shaft (RE: T2401031BS)		1
	T2401031BS	Pinion Shaft w/Gear Assembly (includes #29,31,33,34,37,52)		1
33	GHD20-33	C-Ring	S18	1
34	2401055N	Idle Gear	44T	1
37	2401037N	Idle Gear (2 piece)	35/28T	1
41	BB-6002ZZ	Ball Bearing	6002ZZ	5
42	GHD20-42	C-Ring, Internal	R62	1
43	2401043	Pinion Shaft (RE: T2401043BS)		1
	T2401043BS	Pinion Shaft w/Gear Assembly (includes #,43,49,50)		1
49	2401049N	Idle Gear (RE: T2401043BS)	15/31/23T	1
50	GHD20-50	Oil Seal		1
51	BB-6007ZZ	Ball Bearing	6007ZZ	1
52	2401192	Bushing		1

# 12.4.1 JMD-40GHPF,-45GHPF (powerfeed) Gear Head Assembly – Exploded View

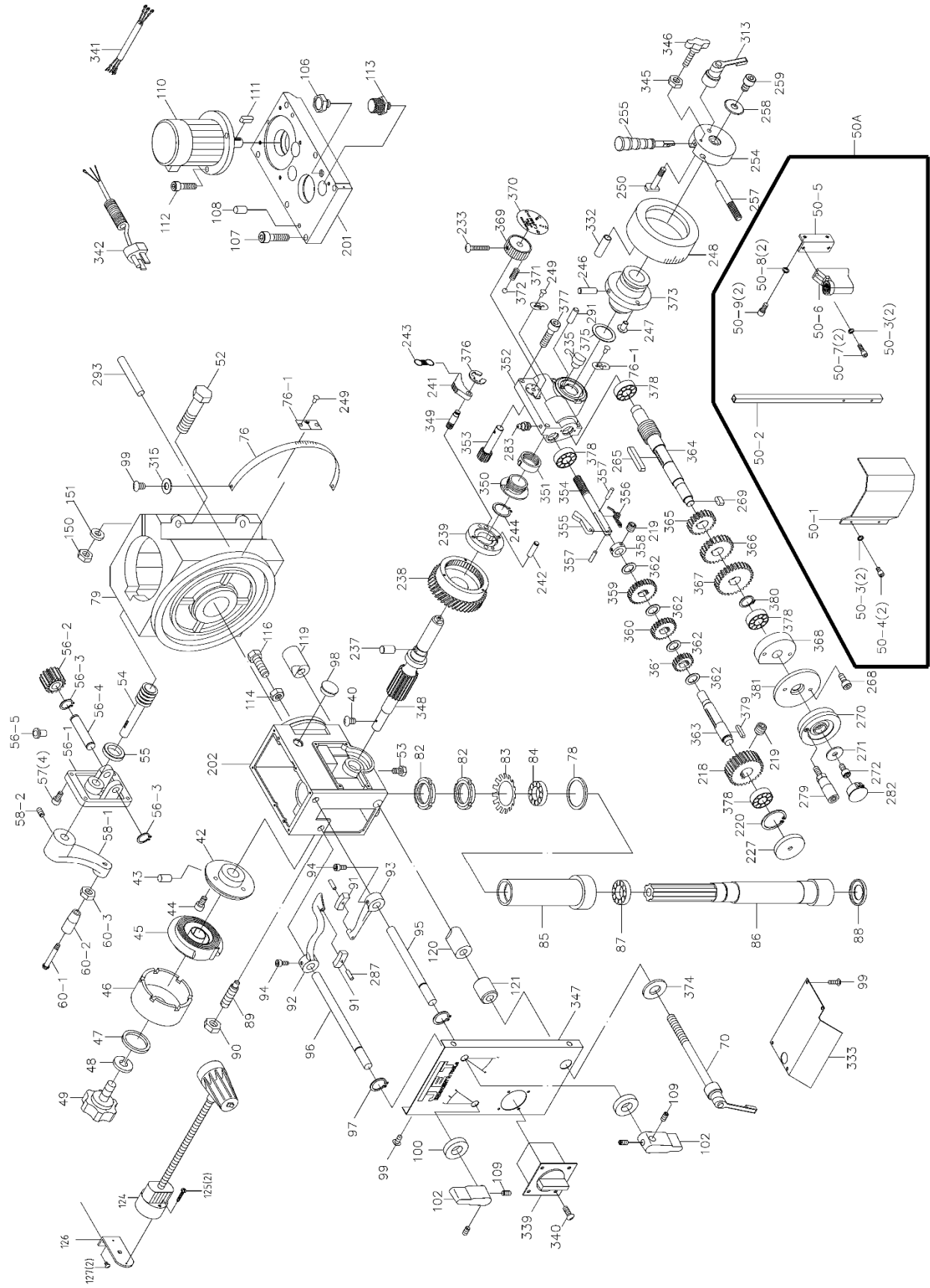

## 12.4.2 JMD-40GHPF,-45GHPF (powerfeed) Gear Head Assembly – Parts List

Index No.	Part No.	Description	Size	Qty
40	GHD20PF-40	Screw	3/16" x 3/8"	1
42	61105	Spring Base		1
43	GHD20PF-43	Spring Pin	3 x 12 mm	2
44	GHD20PF-44	Screw	3/16" x 3/4"	3
45	61103S	Spring and Cover (includes #46)		1
46	61103	Spring Cover (RE:61103S)		1
47	TS-0680021	Flat Washer	1/4"	1
48	TS-0720071	Lock Washer	1/4"	1
49	6185	Lock Knob		1
50A	GHD20-50-A	Chuck Guard Assembly (#50-1 thru 50-9)		1
50-1	JMD18-125-1	Chuck Guard and Support Rod		1
50-2	JMD18-125-2	Support Rod (RE:JMD18-125-1)		1
50-3	TS-2361051	Lock Washer	M5	4
50-4	TS-1502021	Hex Socket Head Cap Screw	M5 x 10	2
50-5	GHD20-50-5	Chuck Guard Bracket		1
50-6	JMD18-125-5	Rotary Support Base		1
50-7	JMD18-125-6	Hex Socket Head Cap Screw	M5 x 15L	2
50-8	TS-1551041	Lock Washer	M6	2
50-9	6286490	Hex Socket Head Cap Screw	M6 x 15L	2
52	TS-0071141	Hex Cap Screw	5/8"-11 x 5-1/2"	2
53	GHD20-53	Oil Plug	1/4"PT	1
54	JMD40GH-55	Worm Shaft		1
55	JMD40GH-56	O-Ring		1
56-1	JMD40GH-57-1	Bracket		1
56-2	JMD40GH-57-2	Worm Gear		1
56-3	F006042	C-Ring, External	S14	2
56-4	JMD40GH-57-4	Shaft		1
56-5	JMD40GH-57-5	Ball Oiler		1
57	TS-0207041	Hex Socket Head Cap Screw	1/4"-20 x 3/4"L	4
58-1	JMD40GH-59-1	Crank		1
58-2	TS-0271052	Set Screw	3/8"-16 x 1/2"L	1
60A	JMD18-201A	Handle Assembly (#60-1 thru 60-3)		1
60-1	JMD18-201-1	Hex Socket Head Cap Screw	3/8" x 16UNC	1
60-2	JMD18-201-2	Handle		1
60-3	TS-0561031	Hex Nut	3/8"-16	1
70	2421003	Handle Rod Assembly		1
76	2401076	Scale		1
76-1	2450060	Pointer		3
78	6112	Rubber Gasket		1
79	2412001G	Casting		1
82	6114	Lock Nut		1
83	GHD20PF-83	Star Washer, External Tooth	M30	1
84	BB-30206	Taper Roller Bearing	30206	1
85	6116-R8	Quill	R8	1
86	6117-R8	Spindle Shaft	R8	1
87	BB-30207	Taper Roller Bearing	30207	1
88	6119	Bearing Cap		1
89	6127	Screw Key		1
90	TS-0561031	Hex Nut	3/8"-16	1
91	2401066	Gear Lever Bracket		2
92	2401067	Gear Lever (Left)		1
93	2401068	Gear Lever (Right)		1
94	TS-0207021	Hex Socket Head Cap Screw	1/4"-20 x 1/2"	1
95	2401070	Lever Shaft (Right)		1
96	2401071	Lever Shaft (Left)		1
97	GHD20PF-97	C-Ring, External	S12	2
98	GHD20PF-98	Oil Sight Glass		1
99	GHD20PF-99	Screw	3/16" x 3/8"	8
100	GHD20PF-100	Oil Seal	G12	2
102	2401075	Speed Lever		2

Index No.	Part No.	Description	Size	Qty
106	GHD20PF-106	Oil Plug		1
107	TS-0209081	Hex Socket Head Cap Screw	3/8"-16 x 3/4"	6
108	GHD20PF-108	Miter Pin		2
109	TS-0267021	Set Screw	1/4"-20 x 1/4"	4
110	JMD40GH-86	Motor	1.5HP 1PH 115/230V	1
	JMD40GH-86MF	Motor Fan		1
	JMD40GH-86MFC	Motor Fan Cover		1
	JMD40GH-86SC	Start Capacitor	400MFD 125VAC	1
	JMD40GH-86CC	Capacitor Cover		1
	JMD40GH-86JB	Junction Box		1
	JMD40GH-86JBC	Junction Box Cover		1
111	GHD20PF-111	Double Rd. Hd. Key	6 x 6 x 30mm	1
112	TS-0209031	Hex Socket Head Cap Screw	3/8"-16 x 3/4"	6
113	GHD20-89	Brass Fitting		1
114	TS-0561071	Hex Nut	5/8"-11	3
116	F008242	Hex Cap Screw	5/8"-11 x 2-1/4"	3
119	6126-1	Collar (threaded)		1
120	6125-1	Collar Nut		1
121	6125-2	Collar		1
124	JMD40GH-124	Lamp Assembly	110V	1
125	TS-2284352	Phillips Pan Head Machine Screw	M4-0.7x35L	2
126	GHD20-126	Lamp Base		1
127	TS-1503031	Hex Socket Head Cap Screw	M6x12L	2
150	TS-0561071	Hex Nut	5/8"-11	2
151	TS-0680081	Flat Washer	5/8"	2
201	2450001G	Head Body Cover		1
202	2450002G	Head Body Casting		1
218	2450008	Worm Gear		1
219	TS-1523011	Set Screw	M6 x 6	4
220	F006033	C-Ring, Internal	R35	4
227	2450014	Cover		1
233	GHD20PF-233	Screw	M4 x 25	1
235	2450020	Release Block		1
236	2450021	Small Pinion Shaft		1
237	2450022A	Cylindrical Key	M8x12	2
238	2450023	Worm Gear		1
239	2450024	Clutch Key Base		1
241	2450026	Clutch Key		2
242	2450027	Spring Pin	Ø5x18L	2
243	2450028	Spring		2
244	GHD20PF-244	C-Ring, External	S25	1
246	2450030	Bushing Pin		1
247	2450031	Bushing Stop		1
248	2450032	Scale Base		1
249	GHD20PF-249	Rivet	Ø2x4L	8
250	2450033	Scale Base Set Screw		1
254	2450037	Handle Hub		1
255	2450038N	Handle Rod		2
257	2450039	Handle Rod Pin		2
258	2450040	Washer		1
259	TS-1504021	Hex Socket Head Cap Screw	M8-1.25 x 12	1
265	GHD20PF-265	Double Rd. Hd. Key	5 x 5 x 32mm	1
266	2450045	Cover		1
268	TS-1502031	Hex Socket Head Cap Screw	M5-0.8 x 12	2
269	GHD20PF-269	Key	4 x 4 x 10mm	1
270	24500470	Handwheel		1
271	GHD20PF-271	Washer		1
272	TS-1503031	Hex Socket Head Cap Screw	M6-1.0 x 12	1
279	JMD40GH-279	Handle Assembly	5/16"	1
282	GHD20PF-282	Plug	7/8"	1
283	GHD20PF-283	Oil Seal		1
287	GHD20PF-287	Spring Pin	4x16mm	2

Index No.	Part No.	Description	Size	Qty
291	2450051	Pin		1
293	HP309	Taper Pin	M6xØ7 (1:48)	1
313	2450063	Handle		1
315	TS-0680011	Flat Washer	3/16"	2
332	GHD20PF-332	Pin		1
333	2450069	Dust Plate		1
339	JMD40GH-339	For/Rev Switch		1
340	GHD20-340	Screw		1
341	JMD40GH-341	Motor Cord	14AWGx5C 300V	1
342	JMD40GH-342	Power Cord	3x3.31mm <sup>2</sup> 12AWG, 5-20P	1
345	TS-0640081	Hex Nut	5/16"-18	1
346	GHD20PF-346	Manual Feed Knob		1
347	JMD40GHPF-347	Name Plate		1
	JET-92	JET Logo (not shown)	92x38MM	1
348	2450086A	Pinion Shaft		1
349	2450097	Clutch Key Pin	Ø7x23L mm	2
350	2450096	Clutch Screw		1
351	2450095	Clutch Nut		1
352	2450068G	Gear Box		1
353	2450081A	Gear Shaft		1
354	2450082A	Speed Change Lever		1
355	2450083A	Stop		1
356	2450084A	Spring Leaf		1
357	GHD20PF-357	Pin	Ø3x10L mm	2
358	2450089A	Fixed Bushing		1
359	2450072A	Gear		1
360	2450071A	Gear		1
361	2450070A	Gear		1
362	2450074A	Washer		4
363	2450073A	Shaft		1
364	2450078A	Transmission Worm		1
365	2450075A	Gear		1
366	2450076A	Gear		1
367	2450077A	Gear		1
368	2450085A	Spacer Ring		1
369	2450079	Speed Lever		1
370	GHD20PF-370	Speed Scale		1
371	290089	Spring		1
372	SB-8MM	Steel Ball	8mm	1
373	2450087A	Clutch Bushing		1
374	GHD20-374	Flat Washer	1/2" x 7/8" x 2"	1
375	2450100	Washer		1
376	GHD20PF-376	E-Retainer Ring	E5	2
377	TS-0208071	Hex Socket Head Cap Screw	5/16"-18 x 1-1/4"L	4
378	CA6003ZZ	Ball Bearing		4
379	GHD20PF-379	Double Rd. Hd. Key	5 x 5 x 28L mm	1
380	GHD20PF-380	C-Ring		1
381	2450088A	Graduated Bottom Plate		1
	LM000286	Warning Label, Mill-Drills (not shown)		1

12.5.1 JMD-40GHPF,-45GHPF (powerfeed) Gears Assembly- Exploded View

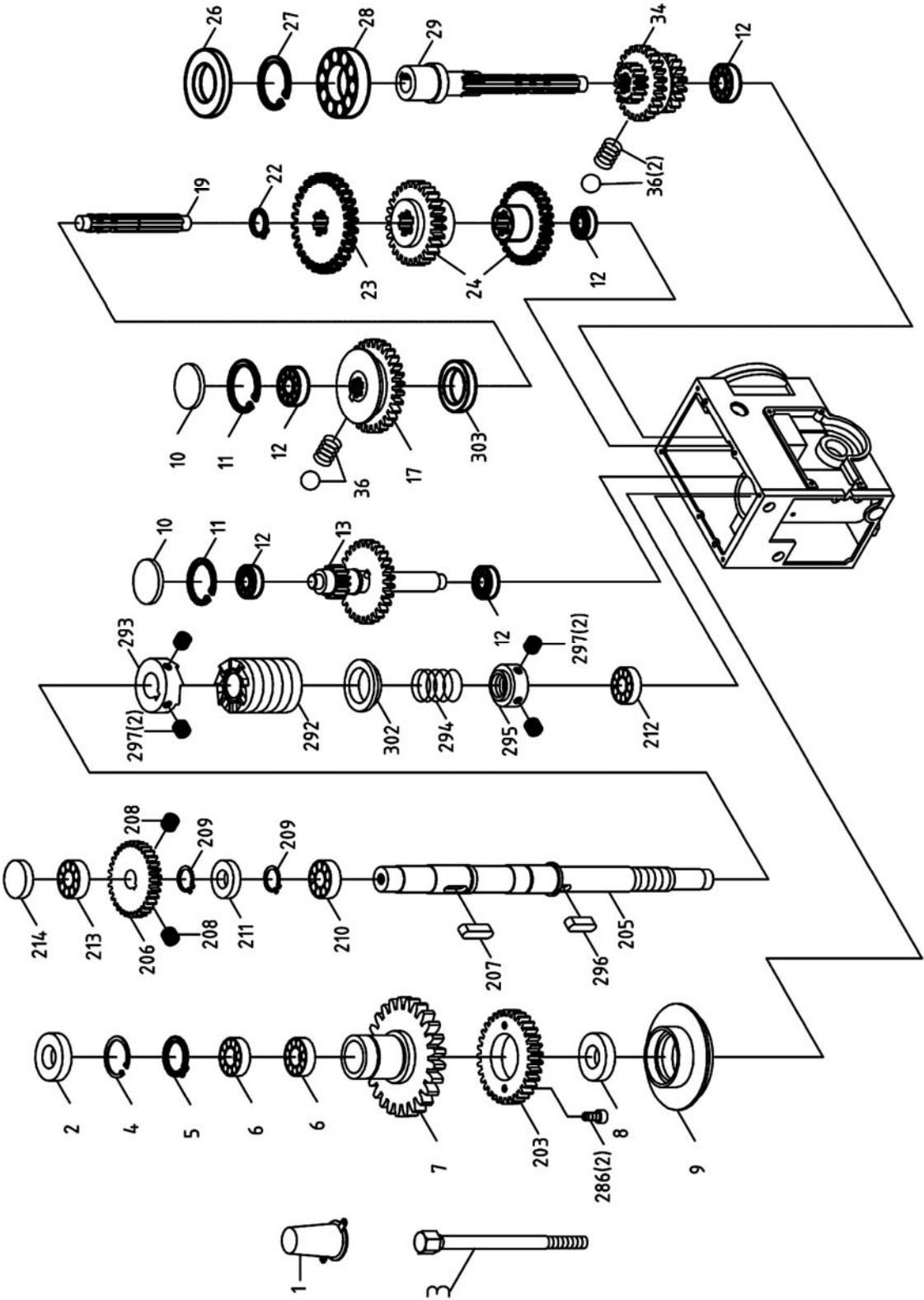

## 12.5.2 JMD-40GHPF,-45GHPF (powerfeed) Gears Assembly – Parts List

Index No.	Part No.	Description	Size	Qty
1	2401001-2	Main Shaft Cover		1
2	GHD20-28	Oil Seal		1
3	JMD45GH-03	Draw Bar	7/16"	1
4	GHD20-4	Retainer Ring, Internal	R68	1
5	GHD20PF-5	Retainer Ring, External	S40	1
6	BB-6008ZZ	Ball Bearing	6008ZZ	2
7	2401006	Idle Gear	53T	1
8	GHD20-7	Oil Seal		1
9	2401008	Oil Seal Ring		1
10	GHD20-9	Dust Cover		2
11	GHD20-10	C-Ring		2
12	BB-6002ZZ	Ball Bearing	6002ZZ	5
13	2401020A	Gear Shaft Assembly	15/41T	1
17	2401029N	Idle Gear	42/16T	1
19	2401031	Pinion Shaft (RE: T2401031BS)		1
	T2401031BS	Pinion Shaft w/Gear Assembly (includes #17,19,22,23,24,303)		1
22	GHD20-33	C-Ring, Ext	S18	1
23	2401055N	Idle Gear	44T	1
24	2401037N	Idle Gear (2piece)	35/28T	1
26	GHD20-50	Oil Seal		1
27	GHD20-42	C-Ring, Internal	R62	1
28	BB-6007ZZ	Ball Bearing	6007ZZ	1
29	2401043	Pinion Shaft (RE: T2401043BS)		1
	T2401043BS	Pinion Shaft W/Gear Assembly (includes #29,34)		1
34	2401049N	Idle Gear (RE: T2401043BS)	15/31/23T	1
36	GHD20-30	Steel Ball W/ Spring	5/16"	3
203	2450003	Idle Gear	33T	1
205	2450004	Transmission Worm		1
206	2450005	Idle Gear	33T	1
207	GHD20PF-207	Double Rd. Hd. Key	5x5x16	1
208	TS-1523011	Set Screw	M6x6	2
209	GHD20PF-209	C-Ring, External	S17	2
210	BB-6003ZZ	Ball Bearing	6003ZZ	1
211	GHD20PF-211	Oil Seal		1
212	BB-6001ZZ	Ball Bearing	6001ZZ	1
213	BB-6202ZZ	Ball Bearing	6202ZZ	1
214	GHD20-214	Oil Seal Cover		1
286	TS-1502031	Hex Socket Head Cap Screw	M5x12	2
292	2450052	Worm Shaft		1
293	2450053	Clutch Block		1
294	2450054	Spring		1
295	2450055	Adjustable Bolt		1
296	GHD20PF-296	Key	5x5x10	1
297	GHD20PF-297	Set Screw	M5x5	4
302	2450057	Washer		1
303	2401192	Bushing		1

12.6.1 JMD-45GH,-45GHPF Table and Base Assembly – Exploded View

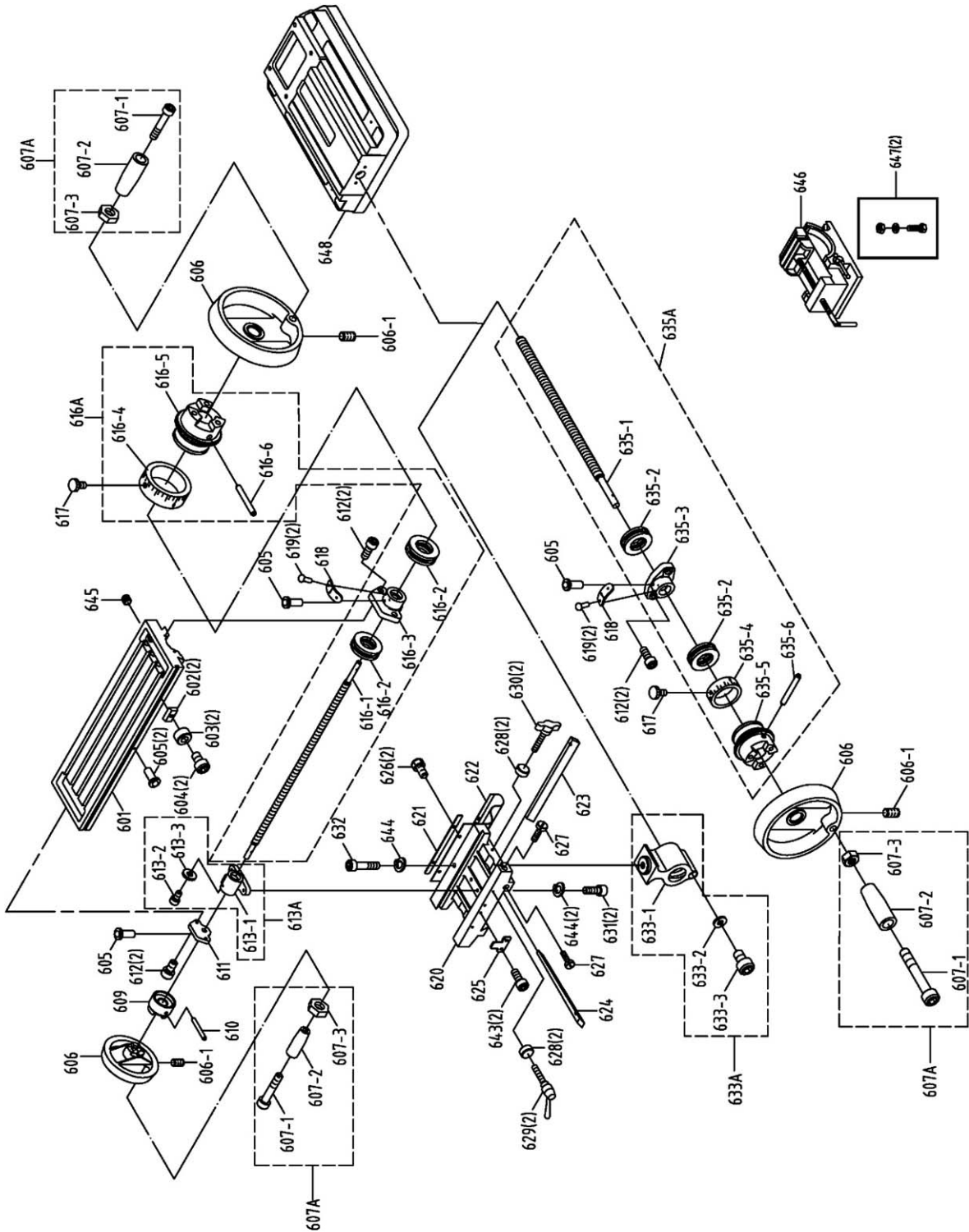



## 12.6.2 JMD-45GH,-45GHPF Table and Base Assembly – Parts List

Index No.	Part No.	Description	Size	Qty
601	JMD18-228G	Table	31L	1
602	JMD18-229	Fixed T-Block		2
603	JMD18-230	Stop Ring		2
604	TS-0207021	Hex Socket Head Cap Screw	1/4"-20x1/2"	2
605	JMD18-368	Ball Oiler	1/4"	5
606	JMD18-201	Table Handwheel		3
606-1	TS-0267041	Set Screw	1/4"-20x3/8"	3
607A	JMD18-201A	Handle Assembly (#607-1 thru 607-3)		3
607-1	JMD18-201-1	Hex Socket Head Cap Screw (RE: JMD18-201-2)	3/8"-16x16	3
607-2	JMD18-201-2	Handle		3
607-3	TS-0561031	Hex Nut	3/8"-16	3
609	JMD18-220	Table Clutch		1
610	JMD18-366	Spring Pin	5x38L mm	1
611	JMD18-222	Left Flange		1
612	TS-0208061	Hex Socket Head Cap Screw	5/16"-18x1"	6
613A	JMD18-223A	Table Nut Set (#613-1 thru 616-3)		1
613-1	JMD18-223	Table Nut	TM23.7-10	1
613-2	TS-1502041	Hex Socket Head Cap Screw	M5-0.8x16	1
613-3	TS-1550031	Flat Washer	M5	1
616A	JMD18-224A	Table Screw Assembly (#616-1 thru 616-6)		1
616-1	JMD18-224	Table Lead Screw		1
616-2	BB-51103	Thrust Bearing	51103	2
616-3	JMD18-226	Right Flange		1
616-4	JMD18-202-1	Graduated Dial		1
616-5	JMD18-202	Dial Clutch		1
616-6	JMD18-366	Spring Pin	5x38L mm	1
617	JMD18N-617	Link Screw		2
618	JMD18-121	Indicator Plate		2
619	JMD18-204-2	Rivet	2mm	4
620	JMD18-216G	Center Base	31L	1
621	JMD18-219	Anti-Dust Plate		1
622	JMD18-217	Anti-Dust Plate Assembly		1
623	JMD18-227	Gib Strip	31L	1
624	JMD18-207	Gib Strip	31L	1
625	JMD18-214	Fixed Block		1
626	TS-0051011	Hex Cap Screw	5/16"-18x1/2"	4
627	JMD18-212	Gib Strip Bolt		2
628	JMD18N-628	Bushing		4
629	JMD18-213-1	Locking Handle		2
630	JMD18-213	Leaf Screw		2
631	TS-0208061	Hex Socket Head Cap Screw	5/16"-18x1"	2
632	TS-0051101	Hex Socket Head Cap Screw	5/16"-18x2-1/4"	1
633A	JMD18-215A	ACME Nut Assembly (#633-1 thru 633-3)		1
635A	JMD18-205A	ACME Nut Assembly (#635-1 thru 635-6)		1
635-1	JMD18-205	Cross Lead Screw	TM23	1
635-2	BB-51103	Thrust Bearing	51103	2
635-3	JMD18-204	Square Flange		1
635-4	JMD18-202-1	Graduated Dial		1
635-5	JMD18-202	Dial Clutch		1
635-6	JMD18-366	Spring Pin	5x38 mm	1
643	TS-0208022	Hex Socket Head Cap Screw	5/16"-24x1/2"	2
644	JMD18N-644	Lock Washer	5/16"	3
645	JMD18N-645	Plug	PT1/4"x3/8"	1
646	365534	Angle Vise		1
647	365534-01	Hardware Package (2 Bolts, 2 Nuts, 2 Washers)		1
648	JMD45GH-648	Base		1
	JMD40GH-AP	Accessory Package (not shown) *		1

\* Contents of JMD40GH-AP Accessory Package:

.....JMD18-020.....	Cutter Arbor .....	.....	1
.....JMD18-022.....	Handle .....	.....	4
.....JMD18-039.....	Handle Rod.....	.....	3
.....JMD18-040.....	Knob .....	.....	3
.....JMD18-050.....	Lock Handle.....	.....	1
.....561704 .....	Drill Chuck w/Chuck Key .....	.....JT6, 1/2" (13mm) .....	1
.....JMD18-086.....	Face Mill Cutter Assembly .....	.....3" (74mm) .....	1
.....JMD18-086A .....	Cutter Insert (Installed) .....	.....	4
.....JMD18-021.....	Chuck Arbor (Installed).....	.....	1
.....365534 .....	Angle Vise .....	.....	1
.....JMD18-058.....	Handle Crank.....	.....	1
.....JMD18-201.....	Wheel.....	.....	3
.....TS-152704 .....	Hex Wrench.....	.....3mm.....	1
.....TS-152705 .....	Hex Wrench.....	.....4mm.....	1
.....TS-152706 .....	Hex Wrench.....	.....5mm.....	1
.....TS-0209051 .....	Hex Socket Cap Screw.....	.....3/8"-16x1" .....	1
.....TS-0680041 .....	Flat Washer .....	.....3/8".....	1
.....365534-01 .....	Hardware Package (2 Bolts, 2 Nuts, 2 Washers) .....	.....	1
.....JMD40GH-PW .....	Plum Wrench .....	.....	1

12.7.1 JMD-45GH,-45GHPF Square Column Assembly – Exploded View

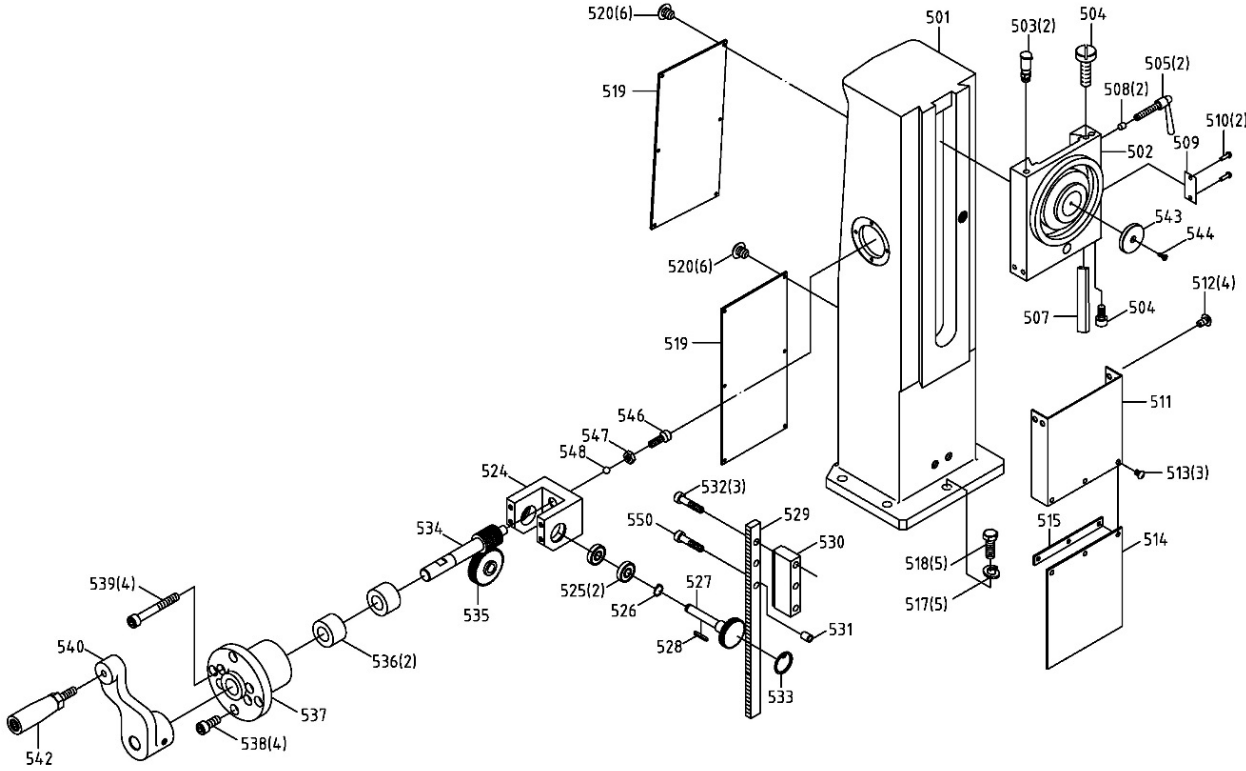

## 12.7.2 JMD-45GH,-45GHPF Square Column Assembly – Parts List

Index No.	Part No.	Description	Size	Qty
501	JMD45GH-501	Vertical Square Column		1
502	JMD45GH-502	Headstock Swivel Base		1
503	JMD45GH-503	Oil Cup	PT1/8"	2
504	JMD45GH-504	Adjustable Screw		2
505	JMD45GH-505	Handle		2
507	JMD45GH-507	Gib		1
508	JMD45GH-508	Bushing		2
509	JMD45GH-509	Index		1
510	JMD45GH-510	Rivet	φ2-5L	2
511	JMD45GH-511	Anti-Dust Plate		1
512	F001216	Phillips Pan Hd Machine Screw BO	M5x10L	4
513	F001175	Phillips Pan Hd Machine Screw BO	M4x8L	3
514	JMD45GH-514	Anti-Dust Plate		1
515	JMD45GH-515	Press Board		1
517	TS-0720131	Lock Washer	5/8"	5
518	TS-0071051	Hex Cap Screw	5/8"-11x2-1/2"L	5
519	JMD45GH-519	Steel Plate		2
520	F001216	Phillips Pan Hd Machine Screw BO	M5x10L	12
524	JMD45GH-524	Bracket		1
525	BB-6003ZZ	Ball Bearing	6003ZZ	2
526	F006045	C-Retainer Ring, External	S17	1
527	JMD45GH-527	Gear Shaft		1
528	JMD45GH-528	Key, Double Rd. Head	5x5x28L mm	1
529	JMD45GH-529	Rack		1
530	JMD45GH-530	Block		1
531	JMD45GH-531	Bushing		1
532	F005671	Hex Socket Head Cap Screw	M12x85L	4
533	F006033	C-Retainer Ring, Internal	R35	1
534	JMD45GH-534	Worm Shaft		1
535	JMD45GH-535	Worm Gear		1
536	JMD45GH-536	Bearing		2
537	JMD45GH-537	Support Flange		1
538	TS-1504051	Hex Socket Head Cap Screw	M8x25L	4
539	TS-1504121	Hex Socket Head Cap Screw	M8x60L	4
540	JMD40GH-59-1	Crank		1
542	JMD18-201A	Handle Assembly		1
543	JMD45GH-543	Swivel Base Flange		1
544	JMD45GH-544	Hex Socket Flat Head Screw		1
546	TS-1504041	Hex Socket Head Cap Screw	M8x20L	1
547	TS-1540061	Hex Nut	M8	1
548	SB-6MM	Steel Ball	Ø6mm	1
550	F005461	Hex Socket Head Cap Screw	M12-1.75x75	1

# 13.0 Electrical Connections, JMD-40GH/45GH series

## 13.1 Wiring Diagram 115V

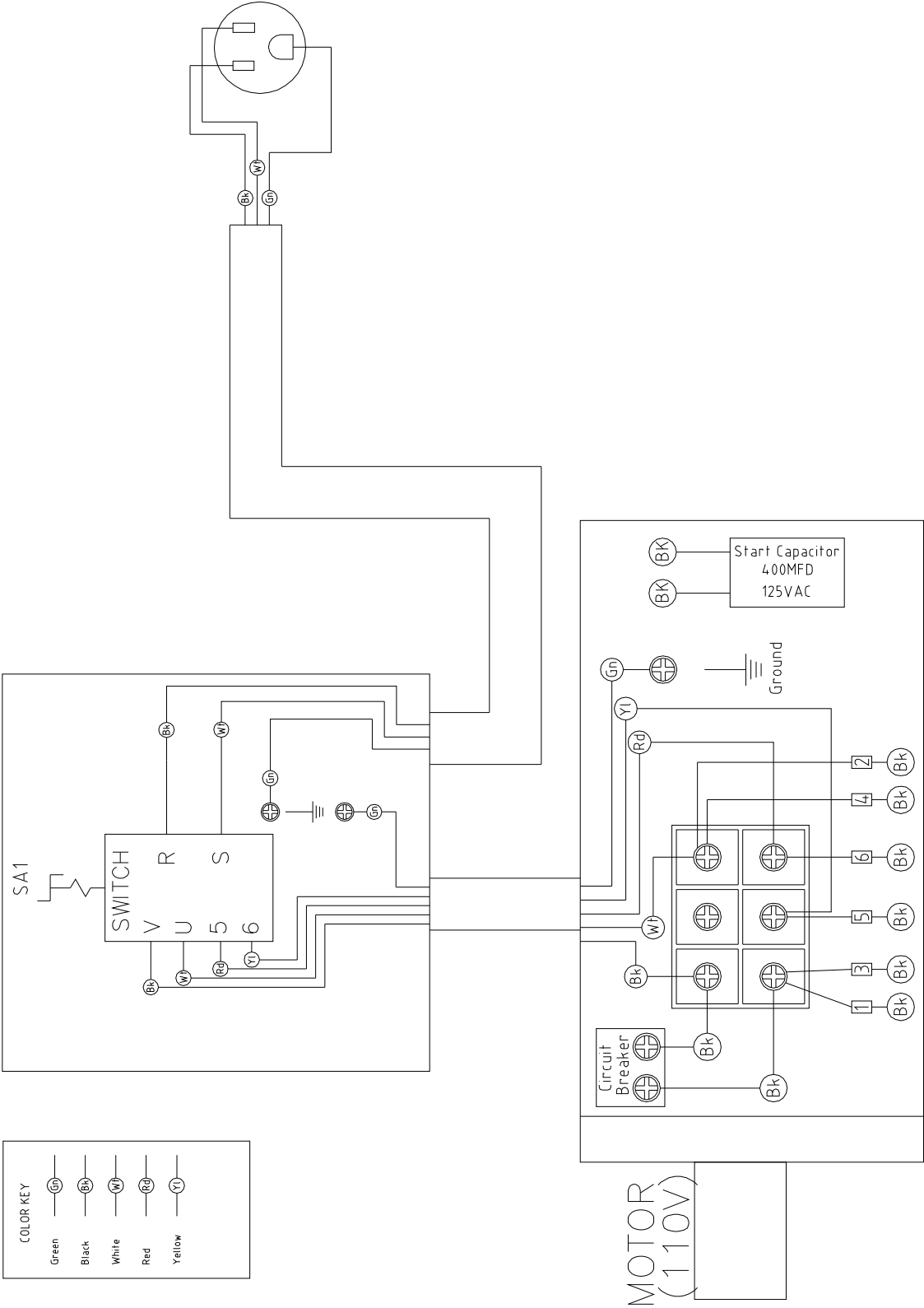

# 13.2 Wiring Diagram 230V

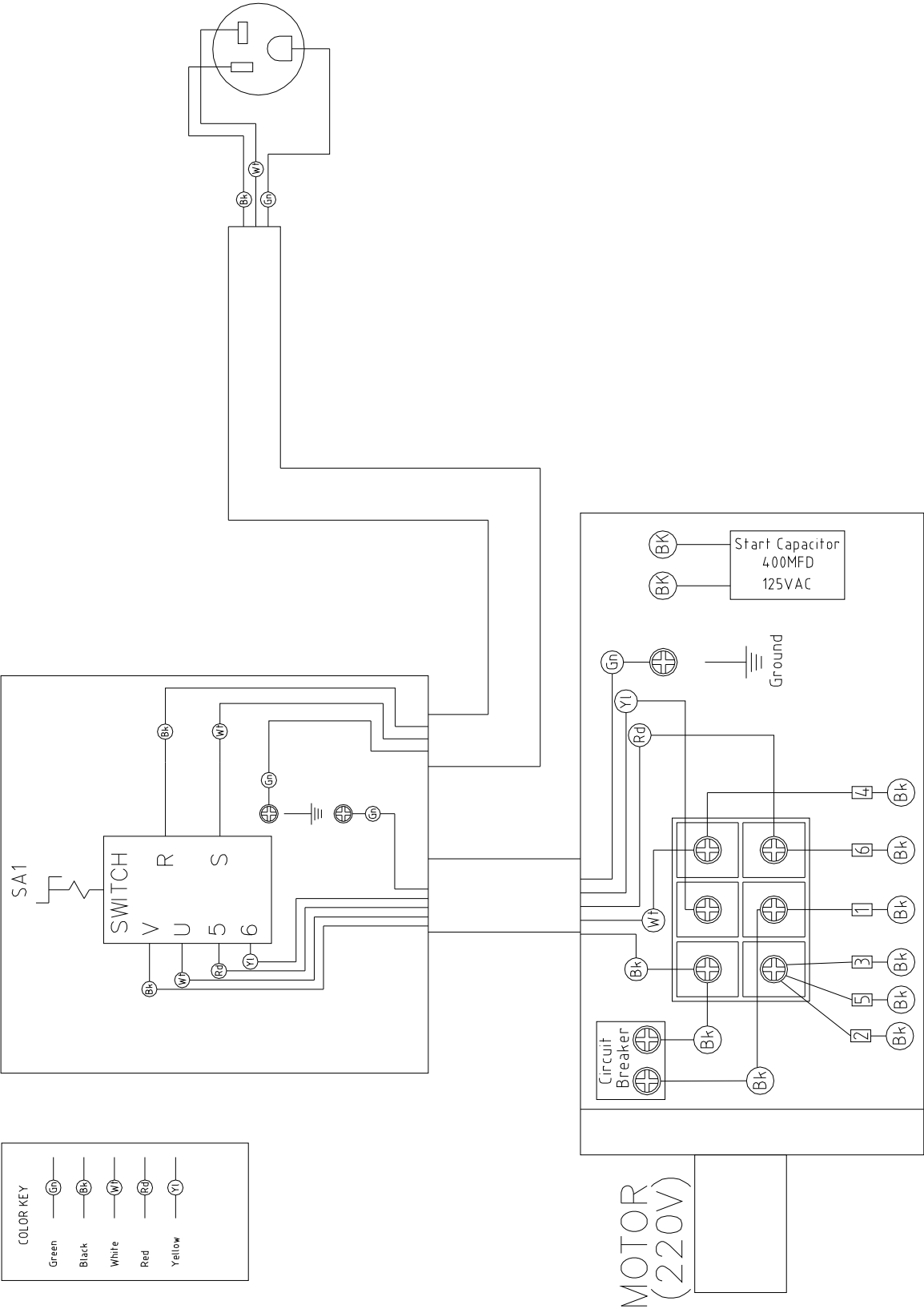

# 14.0 Warranty and service

JET warrants every product it sells against manufacturers' defects. If one of our tools needs service or repair, please contact Technical Service by calling 1-800-274-6846, 8AM to 5PM CST, Monday through Friday.

**Warranty Period**

The general warranty lasts for the time period specified in the literature included with your product or on the official JET branded website.

- JET products carry a limited warranty which varies in duration based upon the product. (See chart below)
- Accessories carry a limited warranty of one year from the date of receipt.
- Consumable items are defined as expendable parts or accessories expected to become inoperable within a reasonable amount of use and are covered by a 90 day limited warranty against manufacturer's defects.

**Who is Covered**

This warranty covers only the initial purchaser of the product from the date of delivery.

**What is Covered**

This warranty covers any defects in workmanship or materials subject to the limitations stated below. This warranty does not cover failures due directly or indirectly to misuse, abuse, negligence or accidents, normal wear-and-tear, improper repair, alterations or lack of maintenance. JET woodworking machinery is designed to be used with Wood. Use of these machines in the processing of metal, plastics, or other materials outside recommended guidelines may void the warranty. The exceptions are acrylics and other natural items that are made specifically for wood turning.

**Warranty Limitations**

Woodworking products with a Five Year Warranty that are used for commercial or industrial purposes default to a Two Year Warranty. Please contact Technical Service at 1-800-274-6846 for further clarification.

**How to Get Technical Support**

Please contact Technical Service by calling 1-800-274-6846. **Please note that you will be asked to provide proof of initial purchase when calling.** If a product requires further inspection, the Technical Service representative will explain and assist with any additional action needed. JET has Authorized Service Centers located throughout the United States. For the name of an Authorized Service Center in your area call 1-800-274-6846 or use the Service Center Locator on the JET website.

**More Information**

JET is constantly adding new products. For complete, up-to-date product information, check with your local distributor or visit the JET website.

**How State Law Applies**

This warranty gives you specific legal rights, subject to applicable state law.

**Limitations on This Warranty**

JET LIMITS ALL IMPLIED WARRANTIES TO THE PERIOD OF THE LIMITED WARRANTY FOR EACH PRODUCT. EXCEPT AS STATED HEREIN, ANY IMPLIED WARRANTIES OF MERCHANTABILITY AND FITNESS FOR A PARTICULAR PURPOSE ARE EXCLUDED. SOME STATES DO NOT ALLOW LIMITATIONS ON HOW LONG AN IMPLIED WARRANTY LASTS, SO THE ABOVE LIMITATION MAY NOT APPLY TO YOU. JET SHALL IN NO EVENT BE LIABLE FOR DEATH, INJURIES TO PERSONS OR PROPERTY, OR FOR INCIDENTAL, CONTINGENT, SPECIAL, OR CONSEQUENTIAL DAMAGES ARISING FROM THE USE OF OUR PRODUCTS. SOME STATES DO NOT ALLOW THE EXCLUSION OR LIMITATION OF INCIDENTAL OR CONSEQUENTIAL DAMAGES, SO THE ABOVE LIMITATION OR EXCLUSION MAY NOT APPLY TO YOU.

JET sells through distributors only. The specifications listed in JET printed materials and on official JET website are given as general information and are not binding. JET reserves the right to effect at any time, without prior notice, those alterations to parts, fittings, and accessory equipment which they may deem necessary for any reason whatsoever. JET® branded products are not sold in Canada by JPW Industries, Inc.

**Product Listing with Warranty Period**

90 Days – Parts; Consumable items
1 Year – Motors; Machine Accessories
2 Year – Metalworking Machinery; Electric Hoists, Electric Hoist Accessories; Woodworking Machinery used for industrial or commercial purposes
5 Year – Woodworking Machinery
Limited Lifetime – JET Parallel clamps; VOLT Series Electric Hoists; Manual Hoists; Manual Hoist Accessories; Shop Tools; Warehouse & Dock products; Hand Tools; Air Tools

NOTE: JET is a division of JPW Industries, Inc. References in this document to JET also apply to JPW Industries, Inc., or any of its successors in interest to the JET brand.



427 New Sanford Road  
LaVergne, Tennessee 37086  
Phone: 800-274-6848  
[www.jettools.com](http://www.jettools.com)