

# ICECUT 300

Spare Parts List  
Pièces de Rechanges  
Lista de Refacciones  
Liste de Peças de Reposição

07/2018



*“Only the best”*

 **WALTER**  
Surface Technologies

## ICECUT300 - WIRING DIAGRAM

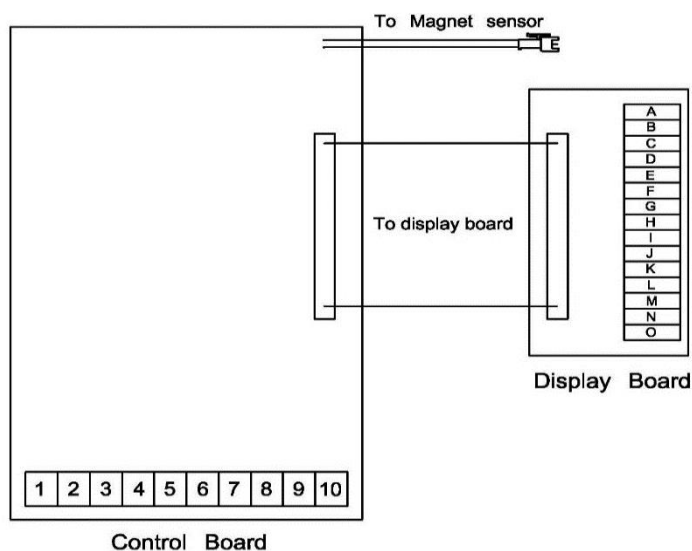

#	FUNCTION	WIRE COLOR
1	Mains Live Input Alimentation secteur phase Entrada de red eléctrica	Brown Brun Marrón
2	Speed controller module Lead wire Fil principal du module de rég de la vitesse Cable conductor de regulador de velocidad	White Blanc Blanco
3	Speed controller module Lead wire Fil principal du module de rég de la vitesse Cable conductor de regulador de velocidad	Red Rouge Rojo
4	Mains Neutral Input Alimentation secteur neutre Cable de neutro de entrada de red eléctrica	Blue Bleu Azul
5	Magnet Positive Output Sortie positive de l'aimant Cable de salida positiva de imán	120V Blue 120V Bleu 120V Azul
6	Magnet Negative Output Sortie negative de l'aimant Cable de salida negativa de imán	Black Noire Negro
7	Field coil Lead wire Fil principal de la bobine de champ Cable conductor bobina de inducción	Blue Bleu Azul
8	Field coil Lead wire Fil principal de la bobine de champ Cable conductor bobina de inducción	Green Vert Verde
9	Carbon brush Lead wire Fil principal de la brosse de carbone Cable conductor escobilla de carbono	Black Noir Negro
10	Carbon brush Lead wire Fil principal de la brosse de carbone Cable conductor escobilla de carbono	Brown Brun Marrón

#	FUNCTION	WIRE COLOR
<b>A</b>	Motor 'Reverse' Switch 0V Interrupteur du moteur en 'marche arrière' 0V Interruptor motor "reverso" 0V	White Blanc Blanco
<b>B</b>	Motor 'Reverse' Switch +5V Interrupteur du moteur en 'marche arrière' +5V Interruptor motor "reverso" +5V	White Blanc Blanco
<b>C</b>	Motor 'Forward' Switch 0V Interrupteur du moteur en 'marche avant' 0 V Interruptor motor "avance" 0V	White Blanc Blanco
<b>D</b>	Motor 'Forward' Switch +5V Interrupteur du moteur en 'marche avant' +5V Interruptor motor "avance" +5V	White Blanc Blanco
<b>E</b>	Magnet Switch 0V Interrupteur de l'aimant 0 V Interruptor imán 0V	White Blanc Blanco
<b>F</b>	Magnet Switch +5V Interrupteur de l'aimant +5V Interruptor imán +5V	White Blanc Blanco
<b>G</b>	Magnet 'ON' LED +5V DEL de l'aimant allumé +5 V LED imán "ON" +5V	White+Green Blanc + Vert Blanco + Verde
<b>H</b>	Magnet 'ON' LED +5V DEL de l'aimant allumé +5 V LED imán "ON" +5V	White+Red Blanc + Rouge Blanco + Rojo
<b>I</b>	Magnet 'ON' LED 0V DEL de l'aimant allumé 0 V LED imán "ON" 0V	White+Brown Blanc + Brun Blanco + Marrón
<b>J</b>	Power 'ON' LED 0V DEL de l'outil en marche 0 V Encendido "ON" LED 0V	White+Black Blanc + Noir Blanco + Negro
<b>K</b>	Power 'ON' LED +5V DEL de l'outil en marche +5 V Encendido "ON" LED +5V	White+Brown Blanc + Brun Blanco + Marrón
<b>L</b>	Motor 'Reverse' LED 0V (BLUE) DEL du moteur en 'marche-arrière' 0 V (BLEUE) Motor "Reverso" LED 0V (AZUL)	White Blanc Blanco
<b>M</b>	Motor 'Reverse' LED +12V (BLUE) DEL du moteur en 'marche-arrière' +12 V (BLEUE) Motor 'Reverso' LED +12V (AZUL)	White Blanc Blanco
<b>N</b>	Motor 'Forward' LED 0V (Green) DEL du moteur en 'marche avant' 0 V (VERTE) Motor "Avance" LED 0V (Verde)	White Blanc Blanco
<b>O</b>	Motor 'Forward' LED +12V (Green) DEL du moteur en 'marche-arrière' +12 V (VERTE) Motor "Avance" LED +12V (Verde)	White Blanc Blanco

**ICECUT300 - EXPLODED VIEW OF MACHINE**

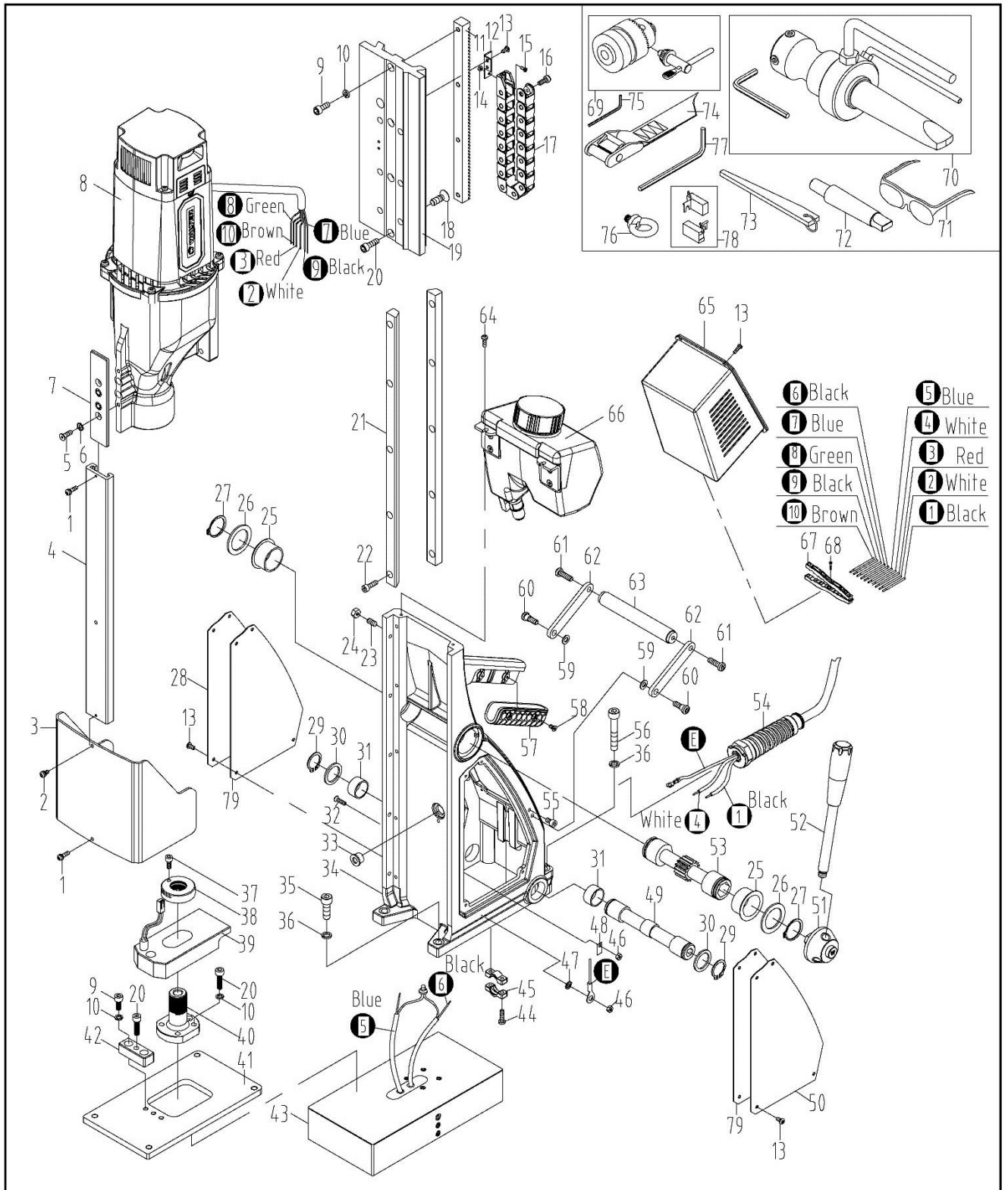

NUMBER	CODE	DESCRIPTION	QTY/pcs
1	48S206	Screw M4x14 Button Head Vis M4x14 à tête bombée Tornillo cabeza botón M4x14	2
2	48S190	Screw M4x8 Button Head Vis M4x8 à tête bombée Tornillo cabeza botón M4x8	1
3	48H427	Guard Icecut 300 Garde Protector	1
4	48H428	Slide channel Glissière du garde Guía deslizante	1
5	48S193	Screw M5x12 CSK HD Vis M5x12 CSK HD Tornillo M5x12 CSK HD	2
6	48K600	M5 CSK Washer Rondelle M5 CSK Arandela M5 CSK	2
7	48H429	Guard support Soutien du garde Elemento protector	1
9	48S211	Screw M6x16 CAP HD Vis M6x16 CAP HD Tornillo M6x16 CAP HD	5
10	48K628	Spring washer Rondelle à resort Arandela de presión	9
11	48H430	Rack Socle de fixation Cremallera	1
12	48H431	Cable chain attachment Attache du câblage Accesorio cadena portacables	1
13	48S208	Screw M4x8 Button Head Vis M4x8 à tête bombée Tornillo cabeza botón M4x8	14
14	48K608	M3 Nut Écrou M3 Tuerca M3	2
15	48S213	Screw M3x8 CSK HD Vis M3x8 CSK HD Tornillo M3x8 CSK HD	2

16	48S194	Screw M5x12 Button Head Vis M5x12 à tête bombée Tornillo cabeza botón M5x12	1
17	48H432	Chain Câble Cadena	1
18	48S196	Screw M8x22 CSK HD Vis M8x22 CSK HD	6
19	48H433	Slide Glissière	1
20	48S197	Screw M6x22 CAP HD Vis M6x22 CAP HD Tornillo CSK HD M8x22	6
21	48H434	Guide bar Barre de guidage Vara/ deslizador	2
22	48S198	Screw M5x16 CAP HD Vis M5x16 CAP HD Tornillo CAP HD M5x16	10
23	48S199	Grub Screw M6x15 Vis sans tête M6x15 Tornillo prisionero M6x15	5
24	48K629	M6 nut Écrou M6 Tuerca M6	5
25	48H435	Bush Bague Buje	2
26	48K630	Capstan Washer Rondelle Arandela de cabrestante	2
27	48K631	Circlip	2

28	48H436	Right side panel Panneau droit Lado derecho del panel	1
29	48K632	Circlip	2
30	48K633	Eccentricity spindle washer Rondelle de l'arbre excentrée Arandela de eje excéntrico	2
31	48H437	Shaft sleeve Manchon Camisa del eje	2
32	48S200	Screw M4x16 CSK HD Vis M4x16 CSK HD Tornillo CSK HD M4x16	2
33	48H307	Cable bush Bague de cable Buje para cable	1
34	48H438	Main housing Boîtier principal Carcasa principal	1
35	48S210	Screw M8x22 CAP HD Vis M8x22 CAP HD Tornillo CAP HD M8x22	2
36	48K602	Spring washer Rondelle à ressort Arandela de presión	4
37	48S215	Screw M5x10 CAP HD Vis M5x10 CAP HD Tornillo CAP HD M5x10	1
38	48K634	Locked nut Écrou freiné Tuerca de seguridad	1
39	48H439	Button assembly Bouton équipé Pieza ensamble	1

40	48H440	Joint sleeve Douille du joint Camisa de unión	1
41	48H441	Swivel base Base pivotante Base giratoria	1
42	48H442	Spacer block Cale d'écartement Block separador	1
43	48H444	Magnet - 120V Aimant – 120V Imán – 120V	1
44	48S235	Screw M4x18 Vis M4x18 Tornillo M4x18	2
45	48H445	Cable clamp Serre-câble Abrazadera de cable	2
46	48K610	M4 nut Écrou M4 Tuerca M4	2
47	48K609	M4 Washer Rondelle M4 Arandela M4	1
48	48H319	Ground label Fiche de mise à la terre Identificación tierra	1
49	48H446	Eccentricity spindle Arbre excentré Eje excéntrico	1
50	48H532	Left side panel Panneau gauche Lado izquierdo del panel	1
51	48H448	Capstan Hub Moyeu Soporte cabrestante	1



52	48H449	Capstan arm Poignée Brazo cabrestante	3
53	48H450	Intermediate gear shaft Arbre-pignon intermédiaire Engranaje intermedio del eje	1
54	48Z234	Power cable - 120V Câble d'alimentation – 120V Cable de alimentación	1
55	48Z236	Screw M5x8 CAP HD Vis M5x8 CAP HD Tornillo CAP HD M5x8	2
56	48S237	Screw M8x43 CAP HD Vis M8x43 CAP HD Tornillo CAP HD M8x43	2
57	48H451	Handle insert Encart de poignée Cubre manija	1
58	48S247	Screw M4x8 CSK HD Vis M4x8 CSK HD Tornillo CSK HD M4x8	4
59	48K635	Washer 6 Rondelle 6 Arandela M 6	2
60	48S248	Bracket screw Support de vis Tornillo de brida	2
61	48S249	Screw M6x15 Button Head Vis M6x15 à tête bombée Tornillo cabeza botón M6x15	2
62	48H452	Capstan bracket Support Brida de cabrestante	2
63	48H453	Handle Poignée Manija	1

64	48S250	Screw M4x12 Button Head Vis M4x12 à tête bombée Tornillo cabeza botón M4x12	2
65	48H455	Control panel assembly - 120V Assemblage de panneau de contrôle – 120V Ensamble de panel de control – 120V	1
66	48H456	Coolant bottle assembly Bouteille liquid de refroidissement Ensamble de botella de refrigerante	1
67	48H457	Clamp Pince Grampa	1
68	48S251	Tapping screw ST2.9x12 Vis-taroux ST2.9x12 Tornillo autoroscante ST2.9x12	3
69	39D007	Chuck Mandrin Mandril	1
70	48H458	Arbor assembly Arbre Eje	1
71	48H424	Safety glass Lunettes de sécurité Gafas de seguridad	1
72	48H459	Arbor shank Tige de l'arbre Cono	1
73	48H460	Drift Broche d'assemblage Cuña	1
74	48H461	Safety belt Sangle de sécurité Correa de seguridad	1
75	48Z003	3mm hexagonal spanner Clé hexagonal en "T" de 3 mm Llave hexagonal de 3mm	1

76	48H462	Stationary ring Anneaux stationnaires Anillo de sujeción/ cáncamo	2
78	48Z010	10mm hexagonal spanner Clé hexagonal en "T" de 10 mm Llave hexagonal de 10mm	1
79	48H465	Spare brush - 120V Brosse de rechange – 120V Escobilla de repuesto – 120V	1pair
		Foam insert Inserts en mousse Insertos de espuma	2

# ICECUT300 - EXPLODED VIEW OF MOTOR AND GEAR BOX

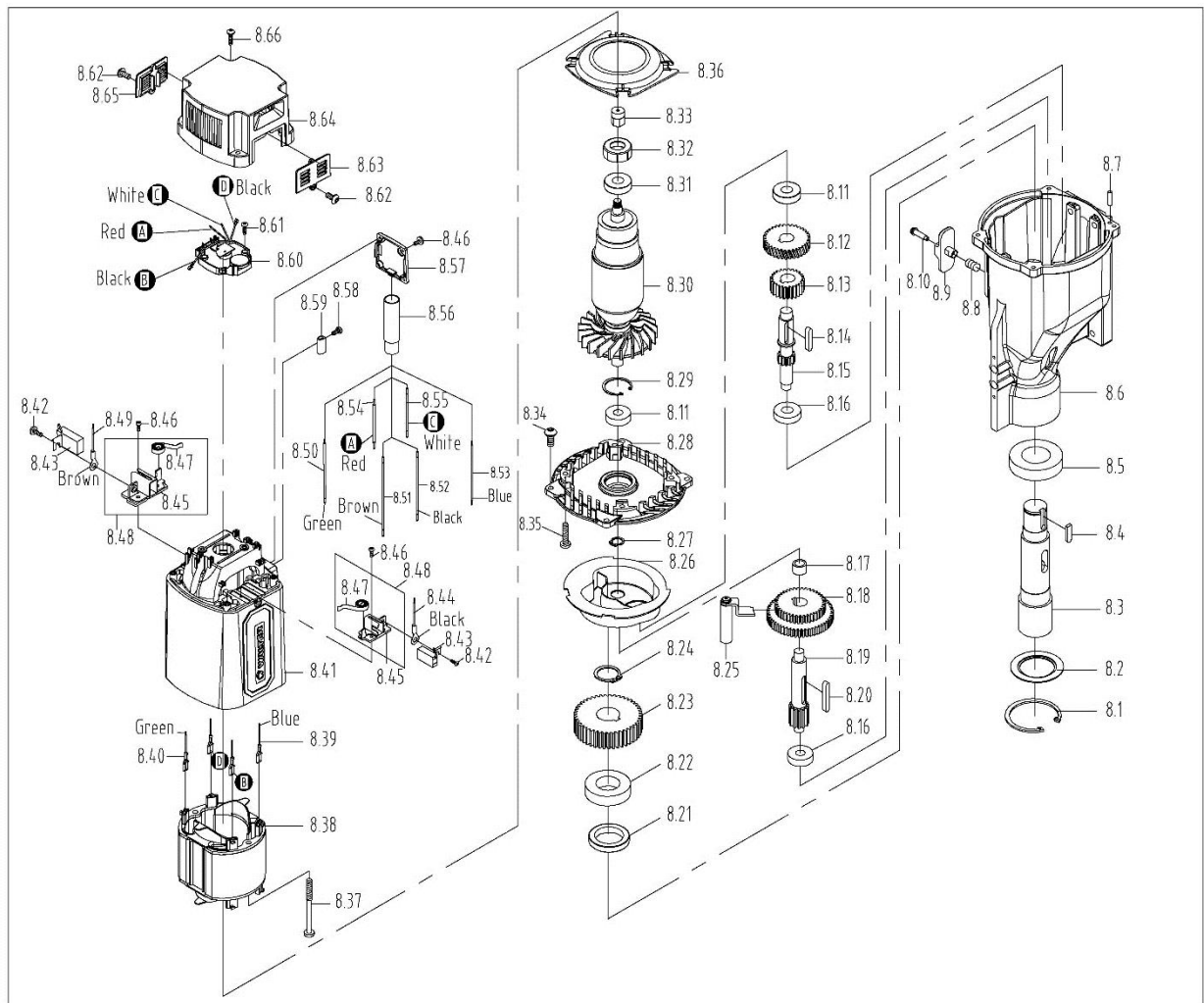

NUMBER	CODE	DESCRIPTION	QTY/ pcs
8	48H467	Motor assembly-120V Moteur – 120V Ensamble motor– 120V	1
8.1	48K636	Circlip	1
8.2	48K637	Oil seal washer Rondelle du joint d’huile Arandela de sello de aceite	1
8.3	48H468	Arbor spindle Arbre Eje	1
8.4	48H469	Key steel Clé en acier Chaveta de acero	1
8.5	48Q039	Rolling bearing 6006 Roulement 6006 Rodamiento de bolas 6006	1
8.6	48H470	Gear box Boîte d’engrenages Caja de engranaje	1
8.7	48H338	Straight Pin Axe lisse Clavija	1
8.8	48H370	Spring Ressort resorte	1
8.9	48H371	Gear lever Levier de commande Palanca de cambios	1
8.10	48H472	Gear lever M4 shoulder bolt Boulon à épaulement M4 du levier de commande Palanca de engranaje eje de tornillo	1
8.11	48Q266	Rolling bearing 6001 Roulement Rodamiento de bolas 6001	2
8.12	48H473	Helical gear Engrenage hélicoïdal Engranaje helicoidal	1

8.13	48H474	Gear Engrenage Engranaje	1
8.14	48H475	Key steel Clé en acier Llave de acero	1
8.15	48H476	Shaft gear Axe de l'engrenage Eje de engranaje	1
8.16	48Q040	Rolling bearing 6000 Roulement 6000 Rodamiento de bolas 6000	2
8.17	48H477	Needle bearing Roulement à aiguilles Rodamiento de agujas	1
8.18	48H478	Sliding gear unit Pignon d'entraînement Engranaje dual	1
8.19	48H479	Shaft gear Axe de l'engrenage Eje de engranaje	1
8.20	48H480	Key steel Clé en acier Llave de acero	1
8.21	48H481	Oil seal Joint d'huile Sello de aceite	1
8.22	48Q041	Rolling bearing 6005 Roulement 6005 Rodamiento de bolas 6005	1
8.23	48H482	Gear Engrenage Engranaje	1
8.24	48K606	Circlip	1
8.25	48H483	Gear lever shaft Arbre de levier Eje de engranaje	1

8.26	48H484	Oil baffle plate Déflecteur d'huile Placa deflectora de aceite	1
8.27	48K638	Circlip	1
8.28	48H485	Gear plate Plateau d'engrenage Placa de engranaje	1
8.29	48K639	Circlip	1
8.30	48H487	Armature-120V Armadura – 120V	1
8.31	48Q267	Rolling bearing 629 Roulement 629 Rodamiento de bolas 629	1
8.32	48H488	Bearing Sleeve Chemise d'arbre sous coussinet Casquillo de cojinete	1
8.33	48H489	Inductor Inducteur Inductor	1
8.34	48S252	Screw M5×16 Button Head Vis M5x16 à tête bombée Tornillo cabeza botón M5×16	4
8.35	48S253	Tapping screw ST4.8×25 Vis-taraud ST4.8x25 Tornillo autoroscante ST4.8×75	4
8.36	48H490	Baffle plate Déflecteur Placa deflectora	1
8.37	48S254	Tapping screw ST4.8×70 Vis-taraud ST4.8x70 Tornillo autoroscante ST4.8×70	2
8.38	48H492	Field coil-120V Bobine de champ – 120V Campo – 120V	1

8.39	48H493	Lead wire Fil de connexion Cable de conexión	1
8.40	48H494	Lead wire Fil de connexion Cable de conexión	1
8.41	48H495	Motor housing Carcasse de moteur Carcasa del motor	1
8.42	48S208	Screw M4x8 Button Head Vis M4x8 à tête bombée Tornillo cabeza botón M4x8	2
8.43	48H497	Brush-120V Brosse – 120V Escobilla – 120V	2
8.44	48H498	Lead wire Fil de connexion Cable de conexión	1
8.45	48H499	Brush frame assembly Assemblage du châssis de la brosse Ensamble porta escobilla	2
8.46	48S221	Tapping screw ST2.9x8 Vis-taraud ST2.9x8 Tornillo autoroscante ST2.9x8	8
8.47	48H500	Spring Ressort Resorte	2
8.48	48H501	Brush frame assembly Assemblage du châssis de la brosse Ensamble porta escobilla	2
8.49	48H502	Lead wire Fil de connexion Cable de conexión	1
8.50	48H503	Lead wire(green) Fil de connexion (vert) Cable de conexión - verde	1
8.51	48H504	Lead wire(brown) Fil de connexion (brun) Cable de conexión - marrón	1



8.52	48H569	Lead wire(black) Fil de connexion (noir) Cable de conexión - negro	1
8.53	48H516	Lead wire(blue) Fil de connexion (bleu) Cable de conexión- azul	1
8.54	48H517	Lead wire(red) Fil de connexion (rouge) Cable de conexión - rojo	1
8.55	48H518	Lead wire(white) Fil de connexion (blanc) Cable de conexión – (blanco)	1
8.56	48H519	Plastic tube Tube en plastique Tubo plástico	1
8.57	48H520	Wire box cover Couvercle du dessus Caja cubre cables	1
8.58	48S220	Screw M3×6 Vis M3x6 Tornillo M3×6	12
8.59	48H350	Terminal	6
8.60	48H522	Speed controller module-120V Module de regulation de la vitesse – 120V Módulo controlador de velocidad – 120V	1
8.61	48S222	Tapping screw ST4.2×12 Vis-taraud ST4.2x12 Tornillo autoroscante ST4.2×12	2
8.62	48S255	Tapping screw ST2.9×12 Vis-taraud ST2.9x12 Tornillo autoroscante ST2.9×12	2
8.63	48H523	Left brush cap Bouchon gauche Tapa cubre escobilla izquierda	1
8.64	48H524	Top Cap Couvercle du dessus Tapa superior	1

8.65	48H525	Right brush cap Bouchon droit Tapa cubre escobilla derecha	1
8.66	48S256	Tapping screw ST4.2x25 Vis-taraud ST4.2x25 Tornillo autoroscante ST4.2x25	4

### ICECUT300 - CONTROL PANEL AND PARTS LIST

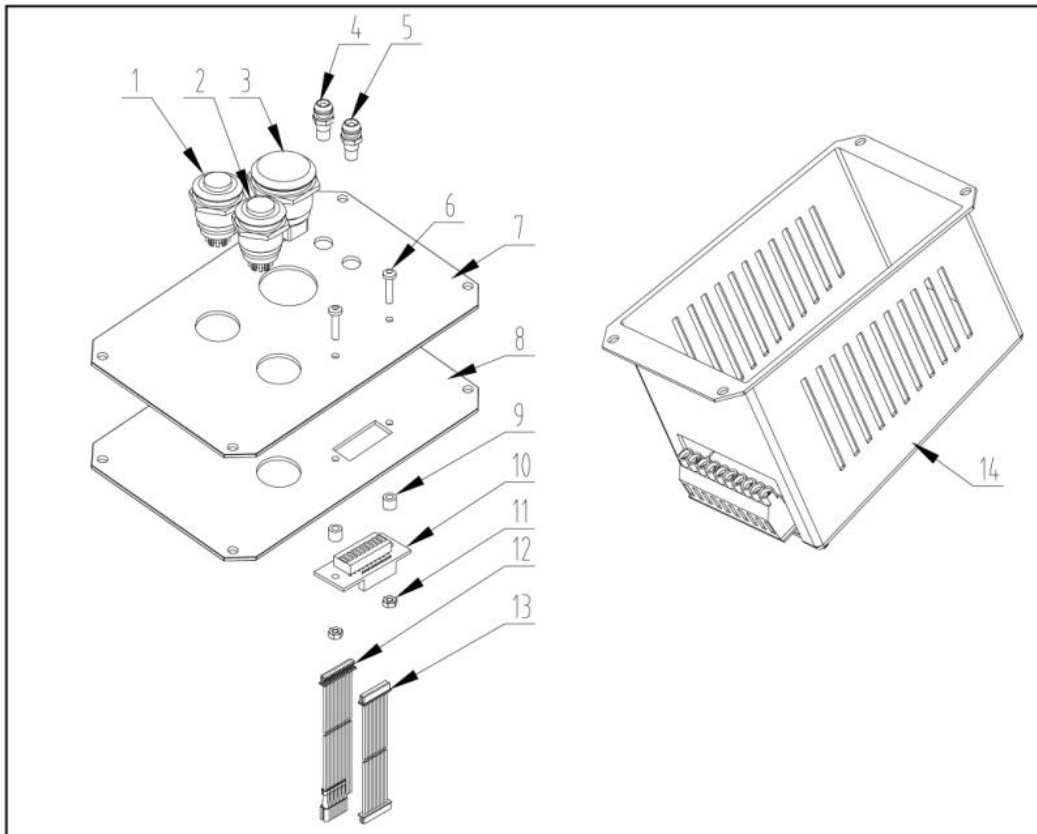

NUMBER	CODE	DESCRIPTION	QTY/ pcs
1	48H397	Green Motor Switch Interrupteur du moteur vert Interruptor verde motor	1
2	48H505	Blue Motor Switch Interrupteur du moteur bleu Interruptor azul motor	1
3	48H506	Magnet Switch Interruption de l'électro-aimant Interruptor imán	1

4	48H507	Red LED DEL rouge LED rojo	1
5	48H508	Green LED DEL vert LED verde	1
6	48S227	Screw M3x12 Button Head Vis M3x12 à tête bombée Tornillo M3x12 BTTN HD	2
7	48H509	Control Panel Cover Couvercle du panneau de contrôle Cubierta panel de control	1
8	48H511	Control Plate - 120V Plateau de contrôle – 120V Placa control -120V	1
9	48H404	Nylon Spacer Espaceur en nylon Espaciador nylon	2
10	48K640	Array Board Boîtier de connexion Tablero electrónico	1
11	48K608	M3 Nut Écrou M3 Tuerca M3	2
12	48H512	Connection line Câble connecteur Línea de conexión	1
13	48H513	Connection line Câble connecteur Línea de conexión	1
14	48H515	E76PCBA - 120V	1