

BALDOR® • RELIANCE 

Product Information Packet

7306

.5HP, 1800RPM, 1PH, 60HZ, 3420C, GRND

Part Detail							
Revision:	AP	Status:	PRD/A	Change #:		Proprietary:	No
Type:	AC	Elec. Spec:	G7WG0385	CD Diagram:	CD0121	Mfg Plant:	
Mech. Spec:	G7-306	Layout:	G7LY0306	Poles:	04	Created Date:	
Base:	RG	Eff. Date:	03-27-2019	Leads:	4#18		

Specs			
Nameplate Output:	.5		
Product Style:	GRINDER		

Nameplate NP3118	
CAT.NO.	7306
HP	.5
PHASE	1
HZ	60
SER.NO.	
SPEC.	G7-306-385
	VOLTS 115/230
	AMPS 3.8/1.9
	RPM 1800

Parts List		
Part Number	Description	Quantity
SA004985	SA G7-306-385	1.000 EA
RA002335	RA G7-306-385	1.000 EA
OC3008F12SP	CYL OIL CAP 8MFD/370V	1.000 EA
G7BA3000	G7-286 BASE DIE CAST	1.000 EA
LD5001A07	CORD & PLUG ASSY 18-3 SJT .33 DIA. 10 AM	1.000 EA
WD4102A01	SR-6L-1 HEYCO STRN RELIEF OR 23MPO6L10 M	1.000 EA
SP9000SP	80600BJ A-H OR 1520237-2 TYCO;2PST,125/2	1.000 EA
HA3205A50	U550-N SWITCH NUT/CARLING	1.000 EA
HW1003A50	LOCKWASHER,1/2",EXT.TOOTHZINC PLATED	1.000 EA
WD1000A22	41473 AMP TERM. (15M/REEL)	4.000 EA
G7CB4500	BASE COVER PLATE 7" GRINDER	1.000 EA
51XW1032A06	10-32 X .38, TAPTITE II, HEX WSHR SLTD S	2.000 EA
RM1005A01A	BASE FOOT & SCREW ASSLY	4.000 EA
11XW1032G06	10-32 X .38, TAPTITE II, HEX WSHR SLTD U	1.000 EA
HW5100A03	WAVY WASHER (W1543-017)	2.000 EA
G7EP3900A01	ENDPLATE, MACH	1.000 EA
G7EP3900A01	ENDPLATE, MACH	1.000 EA
XY1032A02	10-32 HEX NUT DIRECTIONAL SERRATION	4.000 EA
G7FH1800A01GSP	GRINDER GUARD, MACH	1.000 EA
G7FH1801A01	GRINDER GUARD COVER, MACH	1.000 EA
10XF2520A16	SCREW, HEX HD, ZN X	3.000 EA
10XN2520A16	1/4-20 X 1 HEX HEAD CAP SCR, ZINC PLATED	4.000 EA
HA6096A01SP	WHEEL FLANGE, MACH	4.000 EA
HA2040A01SP	SPACER,CRST(WELKER#824500	2.000 EA

Parts List (continued)		
Part Number	Description	Quantity
HW3021C04	SPRG PIN 3/32 DIA .375LGH DRIV-LOK	2.000 EA
G7AP3000A02	WHEEL, 7 X 1 X 60 GRIT B74 X	1.000 EA
G7AP3000A01	WHEEL, 7 X 1 X 36 GRIT B73 X	1.000 EA
XY6311A12SP	HEX NUT 5/8-11	1.000 EA
XY6311A62	5/8-11 NUT L.H. HEX (NC)X (F/S)	1.000 EA
G7FH1802A01GSP	GRINDER GUARD, MACH	1.000 EA
G7FH1803A01GSP	GRINDER GUARD COVER, MACH	1.000 EA
10XF2520A16	SCREW, HEX HD, ZN X	3.000 EA
10XN2520A16	1/4-20 X 1 HEX HEAD CAP SCR, ZINC PLATED	4.000 EA
G6AP1008A01SP	TOOLREST, MACH/PRIMED	1.000 EA
HA6064A01SP	PAINT/PRIME HA6064A01	1.000 EA
10XN2520A12	1/4-20 X 3/4 HEX HEAD CAP	2.000 EA
10XN2520A12	1/4-20 X 3/4 HEX HEAD CAP	2.000 EA
HW1001A25	LOCKWASHER 1/4, ZINC PLT .493 OD, .255 I	2.000 EA
HW1000A25	1/4 SAE FLAT WASHER (FS)	2.000 EA
G6AP1008A01SP	TOOLREST, MACH/PRIMED	1.000 EA
HA6064A01SP	PAINT/PRIME HA6064A01	1.000 EA
HW1001A25	LOCKWASHER 1/4, ZINC PLT .493 OD, .255 I	2.000 EA
HW1000A25	1/4 SAE FLAT WASHER (FS)	2.000 EA
G6AP1002A01	SPARK BREAKER-6",7" & 8" GRINDERS	2.000 EA
10XN3118A10	5/16-18 X 5/8 HEX HEAD CAP	2.000 EA
HW1000A31	5/16 SAE FL WSHR NARROW, ID=.344, OD=.62	2.000 EA
HW1001A31	LOCKWASHER 5/16, ZINC PLT.591 OD, .319 I	2.000 EA
HA6053A01ZP	CLAMP, CAPACITOR 2" DIA, WHITE ZINC PLAT	1.000 EA

Product Information Packet: 7306 - .5HP,1800RPM,1PH,60HZ,3420C,GRND

51XN1032A06	10-32 X .38 HEX SLOTTED SERRATED WASHER	2.000 EA
XY1032A02	10-32 HEX NUT DIRECTIONAL SERRATION	2.000 EA
G7AP5001A01	EYE SHIELD ASSEM.-7",8",10",12"&14"GRIND	1.000 EA
MG1000G01	MUNSELL 5.93PB 3.81/ 2.71	0.014 GA
85XU0407S04	4X1/4 U DRIVE PIN STAINLESS	2.000 EA
WD4006C05	ORANGE, WIRENUT, G-B #13-003 ORG SIZE 73B	2.000 EA
HA3100A29	THRUBOLT 10-32 X 7.00	4.000 EA
LB1008	LABEL, UL	1.000 EA
LB1009N	LABEL,ROTATION DIRECTION (ON ROLLS)	1.000 EA
LB1030	LABEL, OSHA (ON ROLLS)	1.000 EA
LB1307	LABEL, WARNING	1.000 EA
LB1119N	WARNING LABEL	1.000 EA
MN903	INSTR MANUAL FOR GRINDERS 9/03	1.000 EA
LC0279A01	1PH, DV, FIX, GRINDER, CONN FOR LV	1.000 EA
NP3118	ALUM GRINDERS-BUFFERS NO LOGO'S	1.000 EA
35PA1007	PKG GRP, PRINT PK1034A06	1.000 EA

Accessories		
Part Number	Description	Multiplier
GA16E	PEDESTAL LIGHT INDUSTRIAL,STEEL	A8
GA16	PEDESTAL INDUSTRIAL, CAST IRON 6" - 10"	A8
GA14	PEDESTAL FABRICATED STEEL W/SHELVES	A8
GA9	PAIR LIGHTED EYESHIELDS	A8
GA9-1	SINGLE LIGHTED EYESHIELD	A8
GA9S	PAIR EYESHIELDS W/ ON-OFF SWITCH	A8
GA11	PAIR EYESHIELDS	A8
GA24	WATER POT	A8
B73	7" 36 GRIT GRINDING WHEEL	A8
B74	7" 60 GRIT GRINDING WHEEL	A8
BQ1-015-CC	1PH Brake, NEMA 1,110-125 VAC, 50/60Hz	P1
BQ1-015-CP	1PH Brake, Panel 110-125 VAC, 50/60 Hz	P1
DC7	DUST CONTROL UNIT	A8

No performance data has been
assigned to this product.

G7LY0306

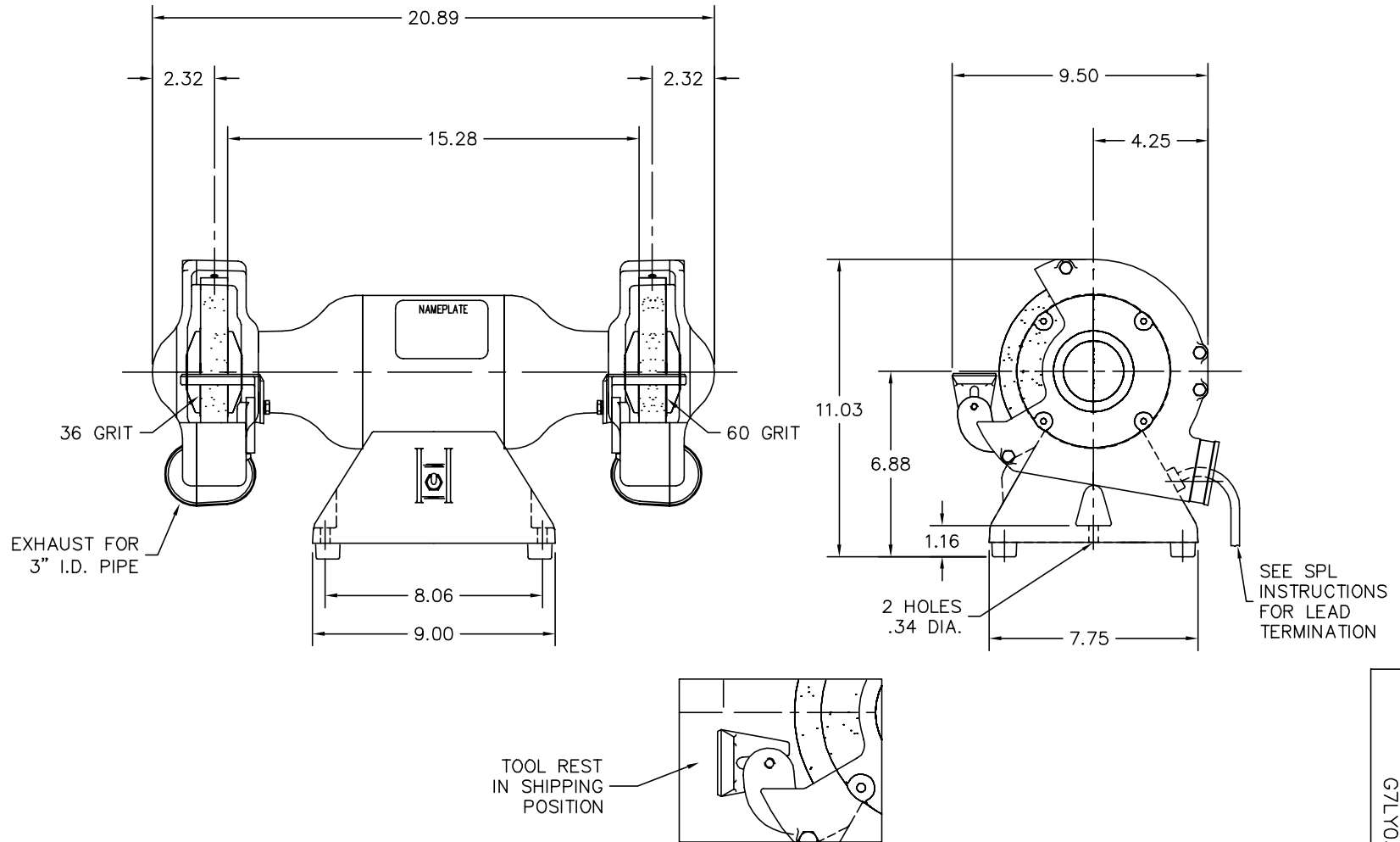

CUSTOMER IS RESPONSIBLE FOR DETERMINING THAT BALDOR'S PRODUCT WILL PERFORM SUITABLY IN THE INTENDED APPLICATION.

REV. DESC: CHG TO SHOW TO PACK THE SPARK BREAKERS AND SHIELDS		
REV. LTR: Y	VERSION: 03	TDR: 000000484468
FILE: \AAA\00102\175		REVISED: 10:55:58 05/31/2011
MTL: -		BY: ENTRUV0

BALDOR

STANDARD 7" DELUXE GRINDER TYPE C

SH 1 of 1

G7LY0306

CD0121

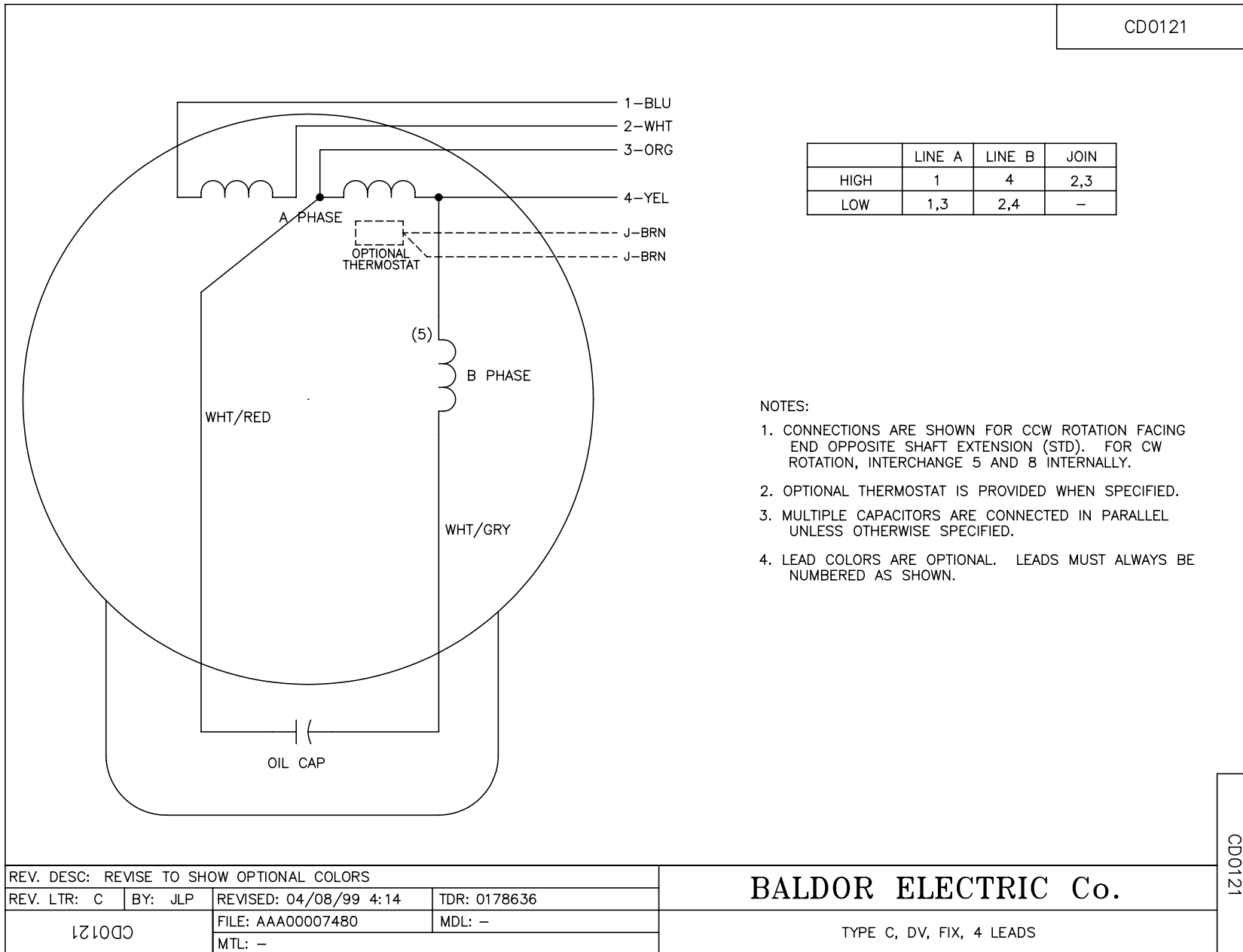

	LINE A	LINE B	JOIN
HIGH	1	4	2,3
LOW	1,3	2,4	-

NOTES:

1. CONNECTIONS ARE SHOWN FOR CCW ROTATION FACING END OPPOSITE SHAFT EXTENSION (STD). FOR CW ROTATION, INTERCHANGE 5 AND 8 INTERNALLY.
2. OPTIONAL THERMOSTAT IS PROVIDED WHEN SPECIFIED.
3. MULTIPLE CAPACITORS ARE CONNECTED IN PARALLEL UNLESS OTHERWISE SPECIFIED.
4. LEAD COLORS ARE OPTIONAL. LEADS MUST ALWAYS BE NUMBERED AS SHOWN.

REV. DESC: REVISE TO SHOW OPTIONAL COLORS			
REV. LTR: C	BY: JLP	REVISED: 04/08/99 4:14	TDR: 0178636
CD0121		FILE: AAA00007480	MDL: -
		MTL: -	

BALDOR ELECTRIC Co.

TYPE C, DV, FIX, 4 LEADS

CD0121