

**BALDOR® • RELIANCE** 

**Product Information Packet**

**7308**

**.5HP, 1500/1800RPM, 3PH, 50/60HZ, 3420M, GRND**

Part Detail							
Revision:	AM	Status:	PRD/A	Change #:		Proprietary:	No
Type:	AC	Elec. Spec:	G7WG0045	CD Diagram:	CD0005	Mfg Plant:	
Mech. Spec:	G7-0311	Layout:	G7LY0311	Poles:	04	Created Date:	
Base:	RG	Eff. Date:	08-21-2018	Leads:	9#18 SEE NOTES		Y

Specs			
Nameplate Output:	.5		
Product Style:	GRINDER		

Nameplate NP0113	
CAT.NO.	7308
HP	.5
PHASE	3
HZ	50//60
SER.NO	
SPEC.	G7-311-45
	VOLTS 208-230/460
	AMPS 1.5-1.4/.7
	RPM 1500//1800

Parts List		
Part Number	Description	Quantity
SA004990	SA G7-311-45	1.000 EA
RA002340	RA G7-311-45	1.000 EA
G7BA3000A01	BASE, MACH	1.000 EA
SP9004	SWITCH HKA270-73 CARLING	1.000 EA
HW3051A01	C/H #15-192 LOCKNUT FOR TOGGLE SWITCHES	1.000 EA
HW1003A50	LOCKWASHER, 1/2", EXT. TOOTH ZINC PLATED	1.000 EA
G7CB4500	BASE COVER PLATE 7" GRINDER	1.000 EA
11XT1032G04	10-32 X 1/4" GRD SCREW	1.000 EA
RM1005A01A	BASE FOOT & SCREW ASSLY	4.000 EA
WD4502A01A02	CONDUIT BOX W/KNOCKOUTS, FOR 7,8 & 10 GR	1.000 EA
51XW1032A06	10-32 X .38, TAPTITE II, HEX WSHR SLTD S	2.000 EA
51XW1032A06	10-32 X .38, TAPTITE II, HEX WSHR SLTD S	2.000 EA
HW5100A03	WAVY WASHER (W1543-017)	1.000 EA
G7EP3900A01	ENDPLATE, MACH	1.000 EA
HW5100A03	WAVY WASHER (W1543-017)	1.000 EA
G7EP3900A01	ENDPLATE, MACH	1.000 EA
HA3100A29	THRUBOLT 10-32 X 7.00	4.000 EA
XY1032A02	10-32 HEX NUT DIRECTIONAL SERRATION	4.000 EA
G7FH1800A01GSP	GRINDER GUARD, MACH	1.000 EA
10XF2520A16	SCREW, HEX HD, ZN X	3.000 EA
G7FH1801A01	GRINDER GUARD COVER, MACH	1.000 EA
10XN2520A16	1/4-20 X 1 HEX HEAD CAP SCR, ZINC PLATED	4.000 EA
G7FH1802A01GSP	GRINDER GUARD, MACH	1.000 EA
10XF2520A16	SCREW, HEX HD, ZN X	3.000 EA

Parts List (continued)		
Part Number	Description	Quantity
G7FH1803A01GSP	GRINDER GUARD COVER, MACH	1.000 EA
10XN2520A16	1/4-20 X 1 HEX HEAD CAP SCR, ZINC PLATED	4.000 EA
HA2040A01SP	SPACER,CRST(WELKER#824500	2.000 EA
HA6096A01SP	WHEEL FLANGE, MACH	4.000 EA
HW3021C04	SPRG PIN 3/32 DIA .375LGH DRIV-LOK	2.000 EA
G7AP3000A01	WHEEL, 7 X 1 X 36 GRIT B73 X	1.000 EA
G7AP3000A02	WHEEL, 7 X 1 X 60 GRIT B74 X	1.000 EA
XY6311A62	5/8-11 NUT L.H. HEX (NC)X (F/S)	1.000 EA
XY6311A12SP	HEX NUT 5/8-11	1.000 EA
G6AP1008A01SP	TOOLREST, MACH/PRIMED	1.000 EA
HA6064A01SP	PAINT/PRIME HA6064A01	1.000 EA
10XN2520A14	1/4 20X7/8 HX HD CAP	2.000 EA
HW1001A25	LOCKWASHER 1/4, ZINC PLT .493 OD, .255 I	2.000 EA
HW1000A25	1/4 SAE FLAT WASHER (FS)	2.000 EA
G6AP1008A01SP	TOOLREST, MACH/PRIMED	1.000 EA
HA6064A01SP	PAINT/PRIME HA6064A01	1.000 EA
10XN2520A14	1/4 20X7/8 HX HD CAP	2.000 EA
HW1001A25	LOCKWASHER 1/4, ZINC PLT .493 OD, .255 I	2.000 EA
HW1000A25	1/4 SAE FLAT WASHER (FS)	2.000 EA
G6AP1002A01	SPARK BREAKER-6",7" & 8" GRINDERS	1.000 EA
10XN3118A10	5/16-18 X 5/8 HEX HEAD CAP	1.000 EA
HW1001A31	LOCKWASHER 5/16, ZINC PLT.591 OD, .319 I	1.000 EA
HW1000A31	5/16 SAE FL WSHR NARROW, ID=.344, OD=.62	1.000 EA
G6AP1002A01	SPARK BREAKER-6",7" & 8" GRINDERS	1.000 EA

Product Information Packet: 7308 - .5HP,1500/1800RPM,3PH,50/60HZ,3420M,GRND

10XN3118A10	5/16-18 X 5/8 HEX HEAD CAP	1.000 EA
HW1001A31	LOCKWASHER 5/16, ZINC PLT.591 OD, .319 I	1.000 EA
HW1000A31	5/16 SAE FL WSHR NARROW, ID=.344, OD=.62	1.000 EA
WD4503A01	T&B 58 C 1, OUTLET BOX LID	1.000 EA
G7AP5001A01	EYE SHIELD ASSEM.-7",8",10",12"&14"GRIND	1.000 EA
MG1000G01	MUNSELL 5.93PB 3.81/ 2.71	0.014 GA
85XU0407S04	4X1/4 U DRIVE PIN STAINLESS	2.000 EA
WD4006B01	TYPE O/B+ 3M SCOTCHLOK WIRE CONNECTOR	6.000 EA
LB1008	LABEL, UL	1.000 EA
LB1009N	LABEL,ROTATION DIRECTION (ON ROLLS)	1.000 EA
LB1030	LABEL, OSHA (ON ROLLS)	1.000 EA
LB1307	LABEL, WARNING	1.000 EA
LB1119N	WARNING LABEL	1.000 EA
MN903	INSTR MANUAL FOR GRINDERS 9/03	1.000 EA
LC0005B01	CONN LABEL GRINDER/BUFFER X	1.000 EA
NP0113	N.P.- DELUXE GRINDERS - BUFFERS	1.000 EA
35PA1007	PKG GRP, PRINT PK1034A06	1.000 EA

<b>Accessories</b>		
<b>Part Number</b>	<b>Description</b>	<b>Multiplier</b>
GA16E	PEDESTAL LIGHT INDUSTRIAL,STEEL	A8
GA16	PEDESTAL INDUSTRIAL, CAST IRON 6" - 10"	A8
GA14	PEDESTAL FABRICATED STEEL W/SHELVES	A8
GA9	PAIR LIGHTED EYESHIELDS	A8
GA9-1	SINGLE LIGHTED EYESHIELD	A8
GA9S	PAIR EYESHIELDS W/ ON-OFF SWITCH	A8
GA11	PAIR EYESHIELDS	A8
GA24	WATER POT	A8
B73	7" 36 GRIT GRINDING WHEEL	A8
B74	7" 60 GRIT GRINDING WHEEL	A8
DC7	DUST CONTROL UNIT	A8

No performance data has been  
assigned to this product.



G7LY0311

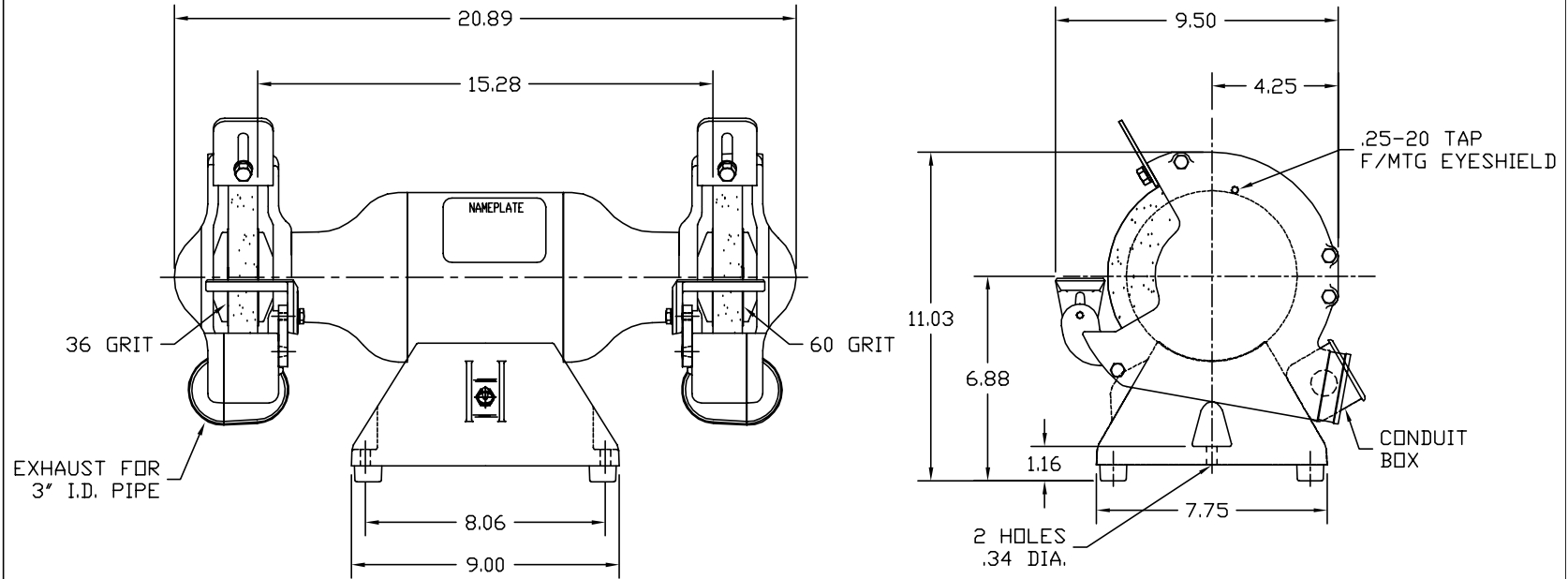

TOOL REST  
IN SHIPPING  
POSITION

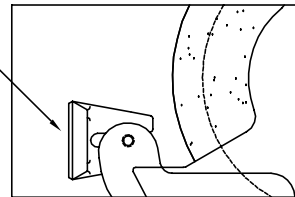

CUSTOMER IS RESPONSIBLE FOR DETERMINING THAT MOTOR PERFORMANCE IS SUITABLE IN THE APPLICATION.

REV. LTR: Q				BY: YTD				REVISED: 11:04:36 07/23/2002				TDR: 256297			
1150A79				FILE: AAA00021035				REF: G7LY0311				MTL: -			

**BALDOR ELECTRIC Co.**

STD 7" DELUXE GRINDER TYPE M, CAT NO'S 7308 & 7309

G7LY0311

CD0005



LOW VOLTAGE  
(2Y)



HIGH VOLTAGE  
(1Y)

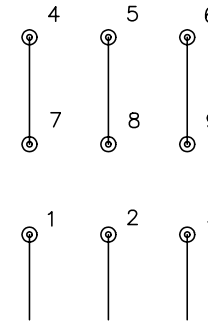

NOTES:

1. INTERCHANGE ANY TWO LINE LEADS TO REVERSE ROTATION.
2. OPTIONAL THERMOSTATS ARE PROVIDED WHEN SPECIFIED.
3. ACTUAL NUMBER OF INTERNAL PARALLEL CIRCUITS MAY BE A MULTIPLE OF THOSE SHOWN ABOVE.
4. LEAD COLORS ARE OPTIONAL. LEADS MUST ALWAYS BE NUMBERED AS SHOWN.

REV. DESC: REVISE TO SHOW OPTIONAL COLORS			
REV. LTR: E	BY: JLP	REVISED: 01/19/99 10:15	TDR: 0171435
900000		FILE: AAA00005140	MDL: -
		MTL: -	

**BALDOR ELECTRIC Co.**

3PH, DV, 9 LEADS

CD0005