

YAK 66/33 Ton - High Tonnage 2 Stage Long Style Jack

Model #92006

NEW

**100%
MADE IN
EUROPE**

3 YEAR WARRANTY



EXCLUSIVE

0.5" 10mm
4.75" 120mm
2.75" 70mm

MODEL 92006

- ▶ Air hydraulic jack for heavy vehicles, practical and effective.
- ▶ The pistons move back automatically; the two descent valves guarantee perfect holding in all situations and controlled speed under load.
- ▶ A complete range of jacks for all stroke and capacity requirements. Ideal for workshops, tire repairers and bodywork shops.

Model #	92006
Style	YAK 222/N
Capacity	66/33 Ton 60/30 Tonne
Net weight	157 lb 71 kg
Working Air Pressure	116-145 psi 8-10 bar

SPECIFICATIONS:

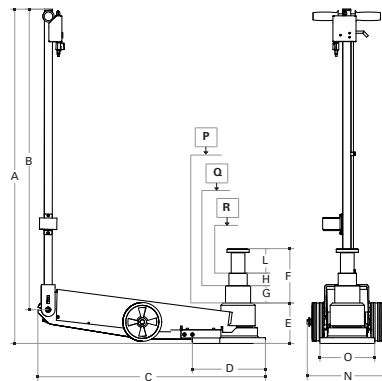

A	56.30" 1430 mm
B	51.97" 1320 mm
C	39.37" 1000 mm
D	12.6" 320 mm
E	8.66" 220 mm
F	9.06" 230 mm
G	4.33" 110 mm
H	4.72" 120 mm
L	NA
N	13.78" 350 mm
O	9.45" 240 mm
P	66 Ton 60 Tonne
Q	33 Ton 30 Tonne
R	NA



YAK 3 Stage 66/33/17 Ton Jack - Low Profile Jack

Model #92007

NEW

**100%
MADE IN
EUROPE**

3 YEAR WARRANTY



EXCLUSIVE

0.5" 10mm
4.75" 120mm
2.75" 70mm

MODEL 92007

Air-hydraulic jacks with pistons moving back automatically. Specifically designed for lifting buses and all vehicles with low profile axles.

Model #	92007
Style	YAK 312
Capacity	66-33-17 Ton 60-30-15 Tonne
Net Weight	110 lb 50 kg
Working Air Pressure	116-145 psi 8-10 bar

SPECIFICATIONS:

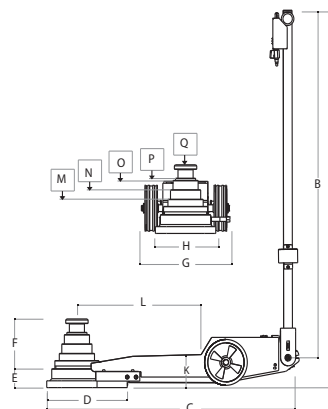

A	54.53" 1385 mm
B	51.77" 1315 mm
C	26" 660 mm
D	13" 330 mm
E	4.74" 120 mm
F	5.31" 135 mm
G	11.81" 300 mm
H	9.84 in 250 mm
K	NA
L	NA
M	66 Ton 60 Tonne
N	33 Ton 30 Tonne
O	17 Ton 15 Tonne
P	NA
Q	NA

