



**Astro Pneumatic
Tool Company**

372 Old US Highway 52 South
Mount Airy, NC 27030

Model:
8050

Product Type:
**ADJUSTABLE DARKENING FILTER
WELDING HELMET - VARIABLE DIN 9-13**

PARTS BREAKDOWN

Call 1.800.221.9705 for questions concerning performance of the product or other inquiries.

Parts List

Index No.	Part No.	Description	Qty
1	8050-01	Shade Knob	1
2	8050-02	Block Nut	2
3	8050-03	Auto Darkening Filter Cartridge	1
4	8050-04	Front Cover Lens	1
5	8050-05	Block Nut	2
6	8050-06	Washer	2
7	8050-07	Shell	1
8	8050-08	Screw	2
9	8050-09	adjustable Limitation Washer	1
10	8050-10	Adjustable Headband	1
11	8050-11	Limitation Washer	1
12	8050-12	Two AAA Alkaline Batteries Box	1
13	8050-13	Four Headband	1
14	8050-14	Sweatband	1
15	8050-15	Inside Cover Lens	1

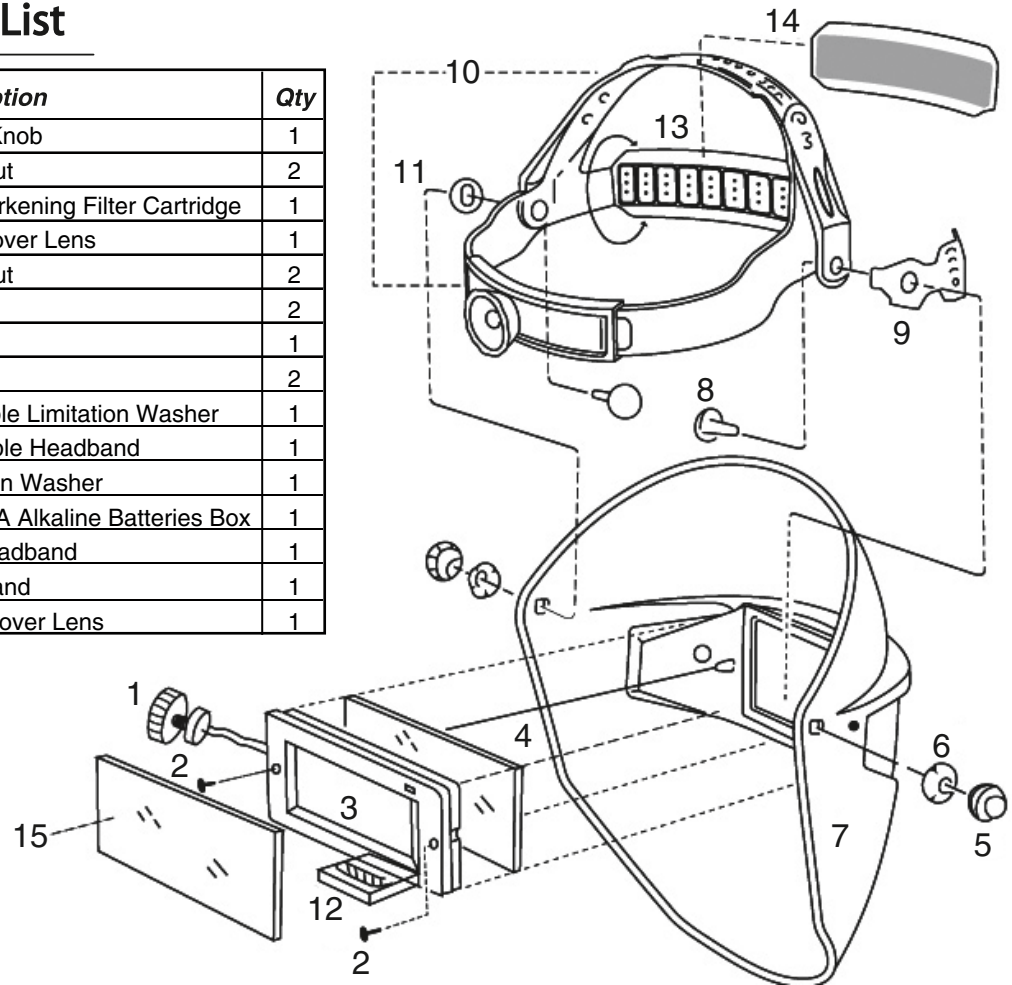

SHADE GUIDE TABLE

Welding Process	Arc Current (Amperes)											
	0.5	2.5	10	20	40	80	125	175	225	275	350	450
SMAW					9	10	11		12		13	14
MIG (heavy)						10	11		12		13	14
MIG (light)						10	11		12		13	14
TIG,GTAW			9	10	11	12		13		14		
MAG/CO ₂						10	11	12		13		14
SAW							10	11	12	13	14	15
PAC								11	12		13	
PAW			8	9	10	11	12		13		14	15

SMAW - Shielded Metal Arc Welding
MIG (Heavy) - MIG on Heavy Metals

TIG,GTAW - Gas Tungsten Arc Welding
PAW - Plasma Arc Welding
SAW - Shielded Semi-Automatic Arc Welding

MIG (Light) - MIG on Light Alloys
PAC - Plasma Arc Cutting