



DMNC 5C STYLE MODELS (single spindle)



MODEL 5C
(with manual 5C closer)



MODEL 5C (back)



UDNC-M1 Controller



MODEL 5C (showing threaded spindle nose)
2 3/16 x 10

Also available as full fourth axis

STANDARD ACCESSORIES:

- ▶ UDNC-M1 Controller
- ▶ Remote cable (for M-Code interface, 15 ft.)
- ▶ Power Cord (105~240 VAC, single phase)
- ▶ Operators Manual, Warranty Card, Locating Keys
- ▶ Manual 5C Collet Closer (Model 5C)
- ▶ Now with Home Limit Switch

OPTIONAL ACCESSORIES

- ▶ Handwheel (MPG-300)
- ▶ Tailstock, (manual & air operated)
- ▶ Remote quill switch (RQS-100) for manual mills
- ▶ Air Operated Collet Closer (DM 105A)
- ▶ PC programming software

Inch/(mm)

MODEL / DMNC	5C
SUB TABLE	5C TYPE
O.D.	N/A
BORE I.D.	N/A
THREADED I.D.	N/A
CENTER HEIGHT	4.33 (110)
MAX RPM	100
SPINDLE TORQUE ft.lbs (kg.m)	90 (12)
SPINDLE BRAKE TORQUE ft.lbs. (kg-m)	
PNEUMATIC	N/A
HYDRAULIC	N/A
RESOLUTION DEGREE	0.001"
MAX LOAD HORIZONTAL (Indexer position)	44 lbs. (20 kg)
MAX LOAD VERTICAL (Indexer position)	22 lbs. (10 kg)
POSITIONING ACCURACY	(+/-) 20 seconds
REPEATABILITY	(+/-) 2 seconds
MOTOR TYPE	Digital AC Servo
SETTING POSITION	Horizontal / Vertical
THRU HOLE DIA. (Spindle)	1.114 (28.30)
POWER SUPPLY	105 ~ 240 VAC Single Phase 20 Amp
GEAR RATIO	45 : 1
SPINDLE RUNOUT	0.0004"(0.01)
SPINDLE TYPE	2 3/16"-10
NET WEIGHT	60.6 lbs. (27.55 kg)

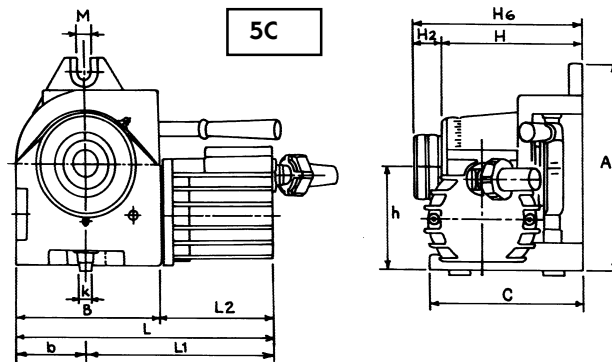

MODEL	A	B	b	C	D	L	L1	L2	H	H2	H6	t	h	k	M
5CA	8.78 (223)	6.46 (164)	3.23 (82)	7.01 (178)	N/A	12.6 (320)	9.37 (238)	6.14 (156)	6.69 (170)	1.22 (31)	7.91 (201)	N/A	4.33 (110)	0.63 (16)	0.67 (17)

FEATURES (5C): MACHINE ZERO HOME SWITCH

The 5C models feature a compact footprint, designed for small VMC's and CNC drilling and tapping centers. The 5C units offer a 2 3/16" - 10 threaded spindle nose, enabling the use of any threaded Hardinge chucks and tooling. The 5C model has an optional air collet closer. This air closer is "button operated" and fits inside the indexer body casting, allowing for horizontal and vertical use. In addition, the integrity of the thru-hole is also maintained, even when the air collet closer is used.