

QuiK-SET™ Tool Presetter Specifications



Measure the tool diameter



Measure the tool length



Lock the Z-axis for quick length adjustment

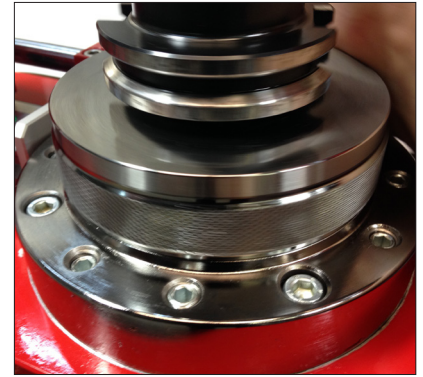

Rotating interchangeable sleeve, with adjustment screws for parallel calibration

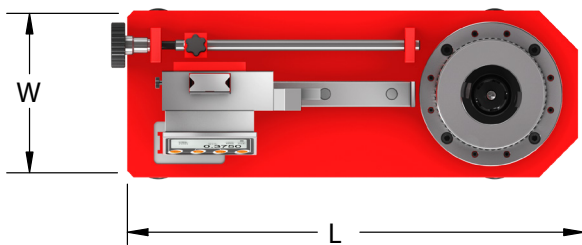
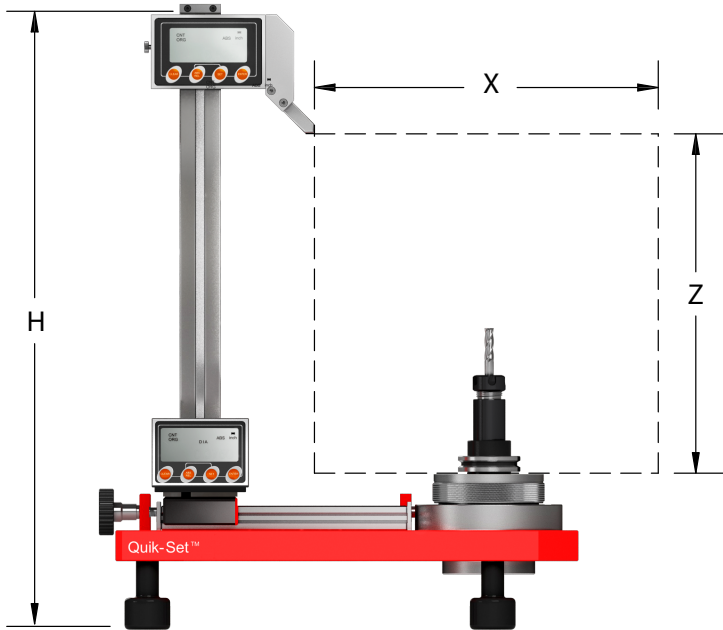

UPC 733101-	42001	42030	42032	42034
QuiK-SET	Z300	Z400	XM	Z600
Accuracy	±.0005 (0,010mm)			
Height Capacity (Z)	12.0in (300mm)	15.8in (400mm)	12.0in (300mm)	23.6in (600mm)
Diameter Capacity (X)	10.0in (250mm)	10.0in (250mm)	15.8in (400mm)	23.6in (600mm)
Presetter Height (H)	23.6in (600mm)	27.6in (700mm)	23.6in (600mm)	36.2in (920mm)
Presetter Length (L)	15.8in (400mm)	15.8in (400mm)	19.7in (500mm)	23.2in (590mm)
Presetter Width (W)	5.7in (145mm)	5.7in (145mm)	7.7in (195mm)	7.7in (195mm)
Measuring Method	Contact Probe			
Power Input	AA Batteries			
Warranty	One Year*			

QuiK-SET Optional Tool Sleeves			
Style	BT30	CAT/BT50	HSK63A-63C
UPC 733101-	42066	42070	42078

SUPPLIED STANDARD WITH CAT/BT40 TOOL SLEEVE