

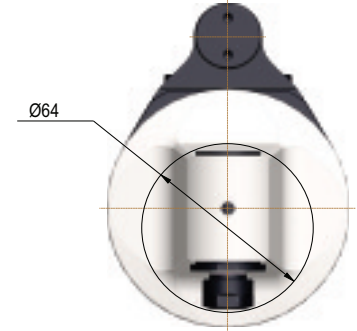

MADE IN ITALY

GFX07L

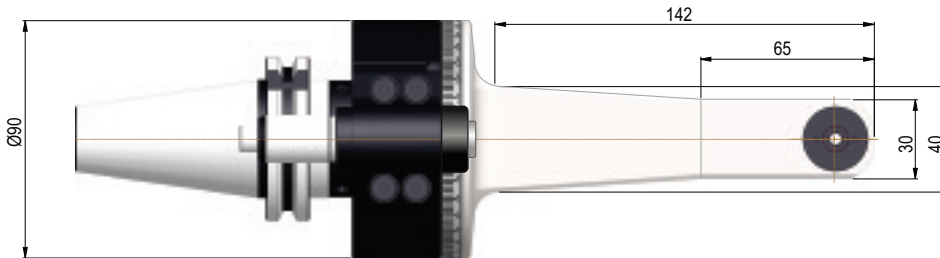
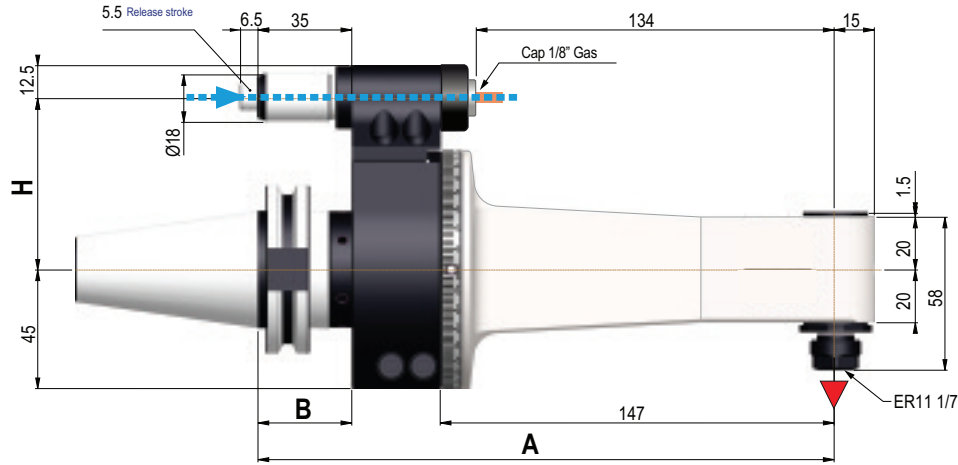

▼ Direction of rotation is opposite to the machine spindle

ROTARY
TOOLING

GFX07L ER 11 Long Fixed 90° Right Angle Heads

Taper	Model	Collet System	A (mm)	B (mm)	H (mm)	End Mill & Drill Cap. (mm)	Tap Size Capacity	Max R.P.M.	Weight (Kg.)	Code No.	Price \$
CAT 40	GFX07L	ER 11	215	35	65-80 (110)*	7	M5	6,000	4.3	381-302	13,884.30
CAT 50	GFX07L	ER 11	215	35	80 (110)*	7	M5	6,000	4.3	381-304	13,884.30
BT 40	GFX07L	ER 11	215	35	65-80 (110)*	7	M5	6,000	4.3	381-306	13,884.30
BT 50	GFX07L	ER 11	221	41	80 (110)*	7	M5	6,000	4.3	381-308	13,884.30
HSK63	GFX07L	ER 11	222	42	65-80 (110)*	7	M5	6,000	4.3	381-310	14,666.70
HSK100	GFX07L	ER 11	225	45	80 (110)*	7	M5	6,000	4.3	381-312	14,832.00

Other tapers available please inquire

() * Optional

Technical Data		GFX 7L
Ratio		1:1
RPM Max	g/min	6,000
Max axial load	N	120
Torque	Nm	5
Weight	Kg.	4.3
Collet	mm	ER-11 0.5mm - 7mm

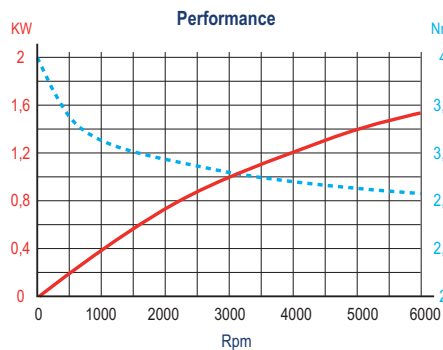

Standard Features & Equipment Included:

- Internal coolant from positioning pin
- Internal air pressure
- Retaining block
- Wrenches
- Grease tube
- Instruction book & Inspection report

