



Adam Equipment

**MDW – 250L**  
**PHYSICIAN SCALE with BMI**

ADAM EQUIPMENT CO. LTD.

p.n. 700660146 Rev. E, February 2011



# CONTENTS

1.0	INTRODUCTION .....	4
2.0	TECHNICAL SPECIFICATIONS .....	4
3.0	DISPLAY AND KEY DESCRIPTIONS .....	5
4.0	SETTING UP THE SCALE .....	6
5.0	FUNCTION .....	8
5.1	WEIGHING .....	8
5.2	MEASURING HEIGHT .....	9
5.3	MEASURING BODY MASS INDEX (BMI) .....	9
6.0	CALIBRATION .....	10
7.0	USER PARAMETERS .....	11
8.0	RS232 COMMUNICATIONS .....	12
9.0	ERROR MESSAGES .....	16
10.0	WARNING .....	16



## 1.0 INTRODUCTION

- The MDW 250L scale is a Digital Physician Scale with Body Mass Index (BMI) readout.
- It is an accurate electronic device with advanced design and stable performance.
- It is designed to measure both the weight and the height of a person and compute the BMI index.

## 2.0 TECHNICAL SPECIFICATIONS

Maximum capacity	250 kg / 550lb
Minimum capacity	2 kg / 4lb
Scale division	0.1Kg / 0.2lb
Height range	60 cm-212 cm / 24"-83"
Division of measurement	0.1 cm / 1/8"
Display	LED display
Size of platform	375 X 275 mm 14.75" X 10.8"
Overall dimension, height pillar in lowest position	570 X 275 X 1310 mm 22.4" X 10.8" X 51.5"
Net weight	13 kg / 29 lb.
Environment for Use	Temperature: 5°C-40°C; Humidity: <85% RH
Power	12vDC 500mA adapter
Battery	Internal, re-chargeable 6V 4Ah, 50 hours approx.
Calibration	External calibration through the keypad.

### 3.0 DISPLAY AND KEY DESCRIPTIONS



KEYS	FUNCTIONS
[On/Off / Zero]	To turn the scale on or off. To zero the scale if the display drifts from zero.
[Tare] ↵	To tare the scale, if necessary. Accept settings as required
[Units / BMI] →	To toggle the weighing unit between Kg and Lb. and to select the BMI function. Move active digit to the right when required.
[Print / Hold] ↑	To lock the reading even if the person to be weighed is moving and also to print the weight details if RS232 interface is installed. Increase value or settings when required.

DISPLAY	DESCRIPTIONS
<b>Kg</b>	Indicates when the scale is weighing in Kilograms.
<b>Lb</b>	Indicates when the scale is weighing in Pounds.
<b>Hold</b>	Indicates when the scale has held the weight reading shown on the display. It will flash until it locks into the stable reading when it will then remain on for a preset time when it has held the displayed reading.
<b>BMI</b>	Indicates when the scale is displaying the Body Mass Index value.
<b>CH</b>	The charge light will be on when the battery is recharging.
<b>AC</b>	This indicates when the scale is being used with the AC adapter.
<b>ZERO</b>	This indicator will be displayed in the left corner when the scale reaches zero.
<b>NET</b>	The Net weight is displayed, Tare weight is at zero.

## 4.0 SETTING UP THE SCALE

- Take the Physician scale out of the box.

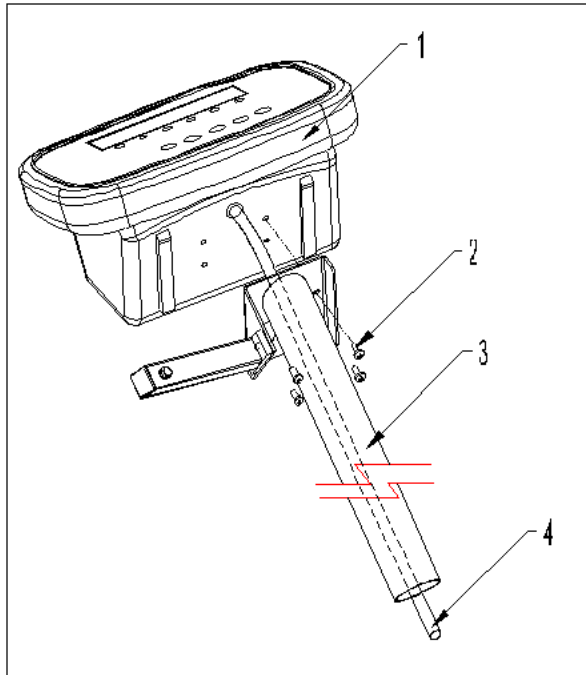

1. Locate the 4 screws (2)
2. Place the cable (4) through the pillar (3).
3. Insert the 4 screws (2) through the holes on the pillar bracket and secure the bracket to the indicator (1),
4. Make sure the screws are securely tightened.

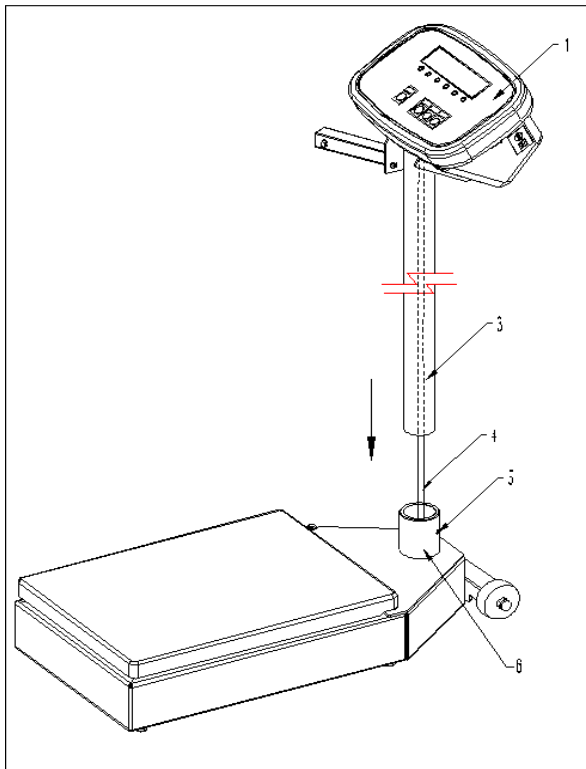

5. Place the cable (4) into the tube support (6) on the scale base.
6. Insert the pillar (3) into the tube support (6).
7. Rotate the pillar to position the indicator (1) in the direction desired, and then secure using the 2 screws (5) into the fixing tube (6).

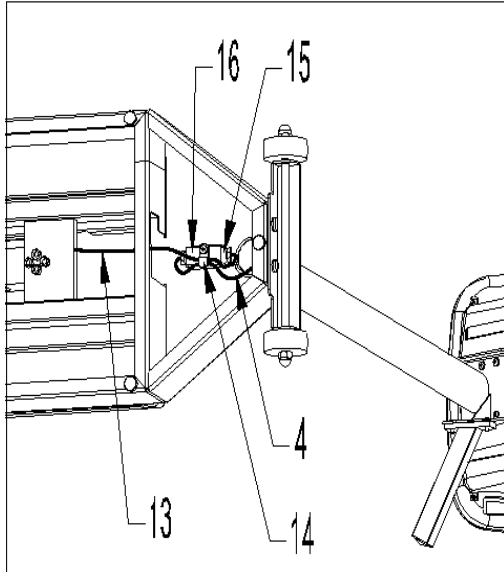

8. Locate the load cell cable (13) ready for connection

9. Place the indicator cable (4) and the load cell cable (13) together near the hole on the base (16).

10. Plug the two connectors (15) together.

11. Position the connector inside the base (16).

12. The cables should be fixed to the base using the clip provided (14).

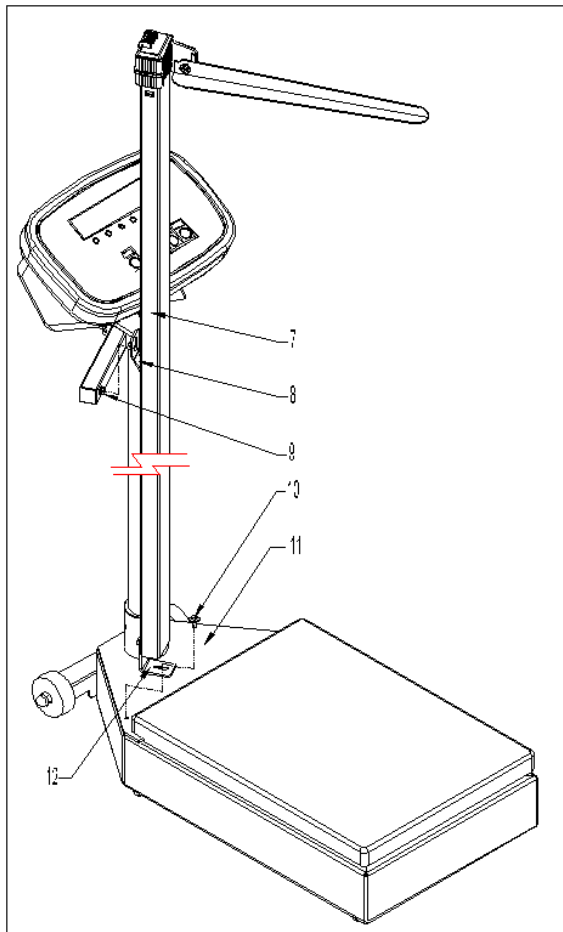

13. Locate the fixing bolt and washer (10) used to secure the height rod to the scale base (11)

14. Locate the height rod (7) onto the fixing points (9) of the upper and lower brackets (8) & (12).

15. Secure the bolt and washer to the bracket on the base (10)

16. Tighten the bolt on the upper bracket (9).



## 5.0 FUNCTION

### 5.1 WEIGHING

- Place the Physician Scale on an even floor and press the **[On/Off]** key.
- The instrument performs a self-test after which it is ready for operation.
- Press the **[On/Off]** key and the machine switches off.
- The person to be weighed can step on to the platform once the scale shows 0.0 on the display. The weight will be display in Kg. or lb. depending on the units chosen by the user.
- If the weighing value is to be tared press the tare key to remove the weight value from the display.
- Press the **[Units]** key for changing the weighing unit to kg or lb. The LED will indicate the chosen weighing unit.
- **Overload display:** When "**FULL**" appears on the display, it shows that the load on the platform is over the maximum capacity. Under these circumstances, it is necessary to reduce the load otherwise the sensor or the platform will be damaged.
- **Hold Function:** To lock the weighing result, press the **[Print/Hold]** key. The LED will flash until a stable reading has been obtained and then it will light up constantly. The weight will be displayed until the hold time has expired (see Sec 7.0) or to manually release the function, press the **[Print/Hold]** key again.
- **Print Function:** To send the weighing result to a printer or computer press the **[Print/Hold]** key when the **[Print/Hold]** key has been set up in the parameter section to work as print function.  
(Print function is only applied for scale with RS232 interface)

## 5.2 MEASURING HEIGHT

- To measure some ones height, it is necessary to extract the measuring rod and place the height arm on top of the head of the person being measured.
- For shorter heights the height arm can be released by pressing the red button on the top of the height rod, and then moving the height arm to the lower section of the height pillar.
- The height is read on the bar at the top of the support. The height can be read in either centimetres or inches, however the BMI function will only accept the centimetre values.

## 5.3 MEASURING BODY MASS INDEX (BMI)

- Once the height has been determined it is possible to enter the height reading into the display ready for the scale to compute the BMI.
- Press and hold the **[Unit/BMI]** key to enter the BMI mode. The display will show the last height value used, “c” 123” or “In123” depending on which weighing unit you are currently using.
- The height entry unit (Cm or In) will be flashing to show you which unit you are currently in, use the Up arrow key to change the height entry unit between Cm to In as required
- Enter your height using the arrow keys, the **[Print/Hold]** /**↑** key will increment the flashing digit, the right arrow, the **[Unit/BMI]** /**→** key, will move the flashing digit to the adjacent digit.
- Press the **[Tare]/↓** key to confirm the value.
- The display will now show the BMI based on the current weight on the scale and the height entered.
- Press the **[Unit/BMI]** key to exit the BMI mode and return to normal weighing.
- The Hold function will work as described above whilst in the BMI mode.

## 6.0 CALIBRATION

Before calibrating the scale, you should ensure that you have a suitable known weight for calibration.

1. When in normal weighing mode with the scale at zero press and hold down **[TARE]** and **[ON / OFF]** keys to enter the calibration mode.
2. If the calibration switch is in the off position on the main PCB inside the scale, the indicator will show “**CRLOFF**” and then exit this mode. If the indicator shows “**CRL - 2**”, the scale is ready for calibration.
3. When the indicator shows “**CRL - 2**”, press the **[TARE]** key to confirm and go to next step, or press the **[ON / OFF]** key to exit the calibration mode.
4. When ‘**00**’ is displayed the scale will begin to calibrate the scale’s zero-point. Ensure that there is no load or weight on the scale’s platform. Press the **[TARE]** key to confirm, or press the **[ON / OFF]** key to exit this mode.
5. A few seconds after the **[TARE]** key has been pressed in step 4 the scale will show “**2500**” and the kg LED, or “**5000**” and the lb LED depending on which unit you chosen, this is the default calibration weight from the factory. Press the **[UNIT]** key to select the calibration weight unit that you want to calibrate in. Press the **[ON / OFF]** key to exit the calibration mode at this point or press the **[Print/Hold]** key to choose a different calibration weight value (50kg, 100kg, 150kg, 200kg, 250kg or 100lb, 200lb, 300lb, 400lb, 500lb); Then put on the weight that you selected and press the **[TARE]** key to confirm the chosen standard weight that was selected earlier. The displayed data will flash on the display and if the scale accepts the calibration data it will calculate and store the information into the EEPROM. If an error has occurred, the scale will display “CAL. Er” and return back to step 4 for re-calibration. If the loaded weight is not within the range of 95% to 105% of the weight value you selected, the scale will not calibrate but display “CAL. Er” and return back to step 4 for re-calibration. )
6. Check the calibration by putting the weight that you calibrated at back on the scale, if it is off repeat the calibration process again.

## 7.0 USER PARAMETERS

This indicator has 4 parameter settings that can be selected.

1. When the scale is in normal weighing mode, press and hold down the **[ON / OFF]** key and the **[UNIT]** key for 3 seconds until 'Setup' is shown on the display.
2. When in the SETUP mode, press the **[Print/Hold]** key to change the flashing digits, and **[TARE]** key to confirm the flashing digits and move to the next parameter setting. Press the **[ON / OFF]** key to exit the set up mode.
3. Parameters setting summary:

Parameter	x/xy	Factory Set	Setting
A.o.t.	00-15	05	Auto-off time: No auto-off = 00. 01-15 minutes auto-off time.
P.H.	0,1,2	1	0 = Only Print Function 1 = Only Hold Function 2 = both HOLD and PRINT function (pressed down less 3s, this key works as Print function; pressed down more than 3s, this key works as HOLD function)
H.t	0-4	0	Hold time: 0 = no time limit. 1 = 10 seconds 2 = 30 seconds 3 = 60 seconds 4 = 120 seconds
S.F.	0-3	0	0 = No RS232 Function. 1 = Continuously outputs display data. 2 = Output display data when PRINT pressed 3 = Bi-directional communication (the scale receives and executes commands from the HOST device)

## 8.0 RS232 COMMUNICATIONS

(Only applied for scale with RS232 interface)

### The Interface parameters are:

RS-232 output of weighing data  
ASCII code  
9600 Baud rate (fixed)  
1 start bit, 8 data bits, 1 stop bit  
No Parity

### Connection details are:

Connector: 9 pin d-subminiature socket  
Pin 3 Output  
Pin 2 Input  
Pin 5 Signal Ground

### 8.1 RS-232 connection between the Scale and the Host:

Scale -----	Cable-----	Host
(DB9 female)-----	(DB9 male) ----	(DB9 female) ----- (DB9 male)
TXD 2	2	2 RXD
RXD 3	3	3 TXD
GND 5	5	5 GND
NC 1	1	1
NC 4	4	4
NC 6	6	6
NC 7	7	7
NC 8	8	8
NC 9	9	9

Note: The indicator pin1,4,6,7,8 and 9 are not connected.

The RS232 function will only operate if PH has been set to 0 or 2.

### 8.2 When Parameter S.F. in section 7 is set to 0 :

No RS232 function. It will not transmit or receive any data although the scale is equipped with RS232. The RS232 function can be only activated when scale is in normal weighing mode.

### **8.3 When Parameter S.F. in section 7 is set to 1 :**

Continuous output of the current displayed reading and unit, and it does not receive any data. The output format is as below:

<LF>< reading, minus, decimal point, weight unit>GR<CR><EXT>

Or <LF>< reading, minus, decimal point, weight unit>NT<CR><EXT>

### **8.4 When Parameter S.F. in section 7 is set to 2 :**

Manually outputs display data when PRINT is pressed. The output format is as below:

<LF>< reading, minus, decimal point, weight unit>GR<CR><EXT>

Or <LF>< reading, minus, decimal point, weight unit>NT<CR><EXT>

### **8.5 When Parameter S.F. in section 7 is set to 3 :**

The baud rate and data format are fixed with responses to serial commands being within 300 milliseconds. One second should be adequate for use as a time-out value by remote (controlling) device.

**8.5.1** The length of the weight field will be 7 digit weight data, one for minus sign, one for decimal point, two for measure unit (e.g. "lb", "kg"). Units of measure abbreviations are always lower case.

If the weight is overcapacity, the scale will return nine '^' characters (the field of minus sign, decimal point, weight data is filled by '^').

If the weight is under capacity, it will return nine '-' characters (the field of minus sign, decimal point, and weight data is filled by '-').

If the zero point has an error, it will return nine '.' characters.

The character will be '-' for negative weight or a space character for positive weight. Minus sign follows after the first digit.

Useless leading zero before digits are suppressed.

#### **8.5.2 Key to symbols used**

<LF> Line Feed character (hex 0AH)

<CR> Carriage Return character (hex 0DH)

<ETX> End of Text character (hex 03)

<SP> Space (hex 20H)

H1H2H3 Three status bytes. Refer to Table1 for definition.

<p> Polarity character including minus sign for negative weight and a space character for positive weight

W1-W7 weight data

<dp> decimal point

U1U2: measure units, kg, lb

### 8.5.3 Commands and response

(1) Command: W<CR> (57h 0dh)

Response:

- <LF>~~~~~u1u2<CR><LF>H1H2H3<CR><ETX>---over capacity
- <LF>\_\_\_\_\_u1u2<CR><LF> H1H2H3 <CR><ETX>---under capacity
- <LF>-----u1u2<CR><LF> H1H2H3<CR><ETX>---zero-point error
- <LF><p>w1 w2 w3 w4 w5 w6 <dp>w7 u1 u2<CR><LF>H1H2H3<CR><ETX> ---Scale is stable, and the current weight unit is kg or lb. With or without decimal point and the position is as per the P9 setting and current unit.

(2) Command: S<CR> (53h 0dh)

Response: <LF> H1H2H3<CR><ETX>

(3) Command: Z<CR> (5ah 0dh)

Response: Zero function is activated and it returns to current scale status. just like pressing **ZERO/ON/OFF** button:

<LF> H1H2H3<CR><ETX>

If ZERO function cannot be activated, it will return to current scale status.

(4) Command: T<CR> (54h 0dh)

Response: TARE function is activated, and then returns scale status. just like pressing **TARE** button:

<LF> H1H2H3<CR><ETX>

If TARE function cannot be activated, it will return to current scale status.

(5) Command: U<CR> (55h 0dh)

Response: Changes units of measure and return scale status with new units, just like pressing **UNIT** button. The new measure unit should be allowed to use as per P11 setting.

<LF>u1u2<CR><LF> H1H2H3<CR><ETX>

(6) Command: X<CR> (58h 0dh)

Response: power off the scale, just like press down the **ON/OFF** key to turn off the scale.

(7) Command: all others

Response: Unrecognized command

<LF>?<CR><ETX>

Table1: The status bits definition:

Bit	Byte 1 (H1)	Byte 2 (H2)	Byte 3 (H3)
0	0=stable	0= not under capacity	01=normal work mode
	1= not stable	1= under capacity	10= hold work mode
1	0= not at zero point	0= not over capacity	00=not define
	1= at zero point	1= over capacity	11= not define
2	always 0	always 0	0= gross weight
			1= net weight
3	0= eeprom OK	always 0	always 0
	1= eeprom error		
4	always 1	always 1	always 1
5	always 1	always 1	always 1
6	always 0	always 1	always 0
7	parity	Parity	parity



## 9.0 ERROR MESSAGES

- |    |                 |   |
|----|-----------------|---|
| 1. | <b>0</b> -----  | zero point is over the setting range                                |
| 2. | <b>0</b> -----  | zero is below the setting range                                     |
| 3. | <b>Ad</b> ----- | ADC is over max. range;   |
| 4. | <b>Ad</b> ----- | ADC is below min. range;  |
| 5. | <b>EEPEr</b>    | there is an error in EEPROM   |
| 6. | <b>CALEr</b>    | there is an error in calibration                                    |
| 7. | <b>CAP.--</b>   | The capacity will be displayed                                      |
| 8. | <b>LoBat</b>    | The voltage of batteries or input power is below 5.6V.              |
| 9. | <b>FULL</b>     | The capacity has been exceeded by the person standing on the scale. |

## 10.0 WARNING

- Do not dismantle the weighing machine without following the necessary instructions.
- Do not jump while standing on the platform. This may damage the sensor inside.
- Do not move the weighing machine violently and abruptly. Always move and put down the weighing machine gently.
- Wipe any stains with a soft damp cloth using a detergent, then wipe clean with a dry soft cloth. Do not use organic solutions or boiling water to clean stains. Do not use a water spray for cleaning.
- Keep the weighing machine in a dry and clean environment. Do not expose it to outdoor use or use it in locations near fire, under direct sunshine or with high temperature.
- When lifting the height meter, extract it directly upwards without using excessive force.
- Do not lift the scale using the height pillar. Lift by the base only.





### Manufacturer's Declaration of Conformity

This product has been manufactured in accordance with the harmonised European standards, following the provisions of the below stated directives:

Electro Magnetic Compatibility Directive 2004/108/EC

Low Voltage Directive 2006/95/EC

Adam Equipment Co. Ltd.  
Maidstone Road, Kingston,  
Milton Keynes, MK10 0BD  
United Kingdom

### FCC COMPLIANCE

This equipment has been tested and found to comply with the limits for a Class A digital device, pursuant to Part 15 of the FCC Rules. These limits are designed to provide reasonable protection against harmful interference when the equipment is operated in a commercial environment. The equipment generates, uses, and can radiate radio frequency energy and, if not installed and used in accordance with the instruction manual, may cause harmful interference to radio communications. Operation of this equipment in a residential area is likely to cause harmful interference in which case the user will be required to correct the interference at his own expense.

Shielded interconnect cables must be employed with this equipment to insure compliance with the pertinent RF emission limits governing this device.

Changes or modifications not expressly approved by Adam Equipment could void the user's authority to operate the equipment.

### WEEE COMPLIANCE

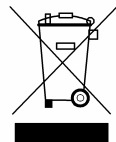

Sealed Lead Acid  
Battery  
Must be recycled  
Properly

Any Electrical or Electronic Equipment (EEE) component or assembly of parts intended to be incorporated into EEE devices as defined by European Directive 2002/95/EEC must be recycled or disposed using techniques that do not introduce hazardous substances harmful to our health or the environment as listed in Directive 2002/95/EC or amending legislation. Battery disposal in Landfill Sites is more regulated since July 2002 by regulation 9 of the Landfill (England and Wales) Regulations 2002 and Hazardous Waste Regulations 2005. Battery recycling has become topical and the Waste Electrical and Electronic Equipment (WEEE) Regulations are set to impose targets for recycling.

**ADAM EQUIPMENT** is an ISO 9001:2008 certified global company with more than 35 years experience in the production and sale of electronic weighing equipment.

Adam products are predominantly designed for the Laboratory, Educational, Medical, retail and Industrial Segments. The product range can be described as follows:

- Analytical and Precision Balances
- Compact and Portable Balances
- High Capacity Balances
- Moisture analysers / balances
- Mechanical Scales
- Counting Scales
- Digital Weighing/Check-weighing Scales
- High performance Platform Scales
- Crane scales
- Medical Scales
- Retail Scales for Price computing

For a complete listing of all Adam products visit our website at  
[www.adamequipment.com](http://www.adamequipment.com)

© Copyright by Adam Equipment Co. Ltd. All rights reserved. No part of this publication may be reprinted or translated in any form or by any means without the prior permission of Adam Equipment.

Adam Equipment reserves the right to make changes to the technology, features, specifications and design of the equipment without notice.

All information contained within this publication is to the best of our knowledge timely, complete and accurate when issued. However, we are not responsible for misinterpretations which may result from the reading of this material.

The latest version of this publication can be found on our Website.

[www.adamequipment.com](http://www.adamequipment.com)