

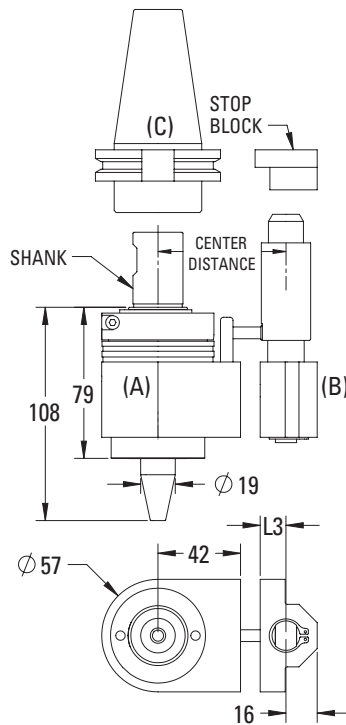

**How to Order**

The TapWriter® adapts to machining centers with automatic change, using a locking stop arm, similar to those used with self reversing tapping attachments. Select the installation method you prefer as shown below. Please select the TapWriter® (A), stop arm (B), and CAT, SK, or BT shank (C), to fit your machine. Please order accessories like torque bars, ready made stop arms and stop blocks separately.

**TapWriter® with Stop Arm Bar and Stop Block Installation**



**(A) TapWriter® CNC Dot Peen Marking Tool**

Model	Order code	Shank	Weight kg
TAPWRITER	57820	20 mm	1.7
	57825	25 mm	
	57810	1"	

**(B) Stop Arm Assembly**

Center Distance (42+L3)	Order code	L3
55	3925551	13
65	3925651	23
80	3925801	38

**TapWriter® with Stop Arm Plate and Torque Bar Installation**

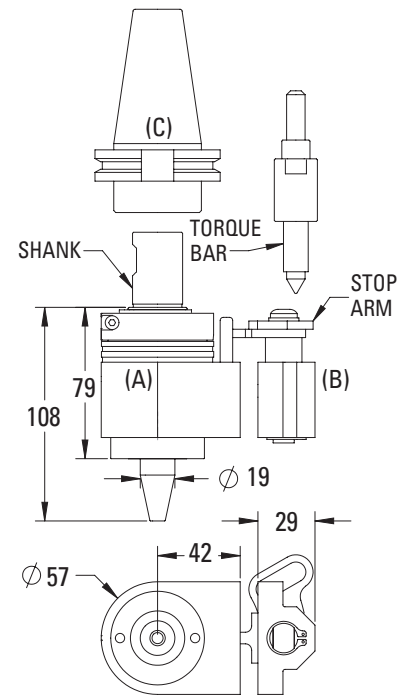

**(A) TapWriter® CNC Dot Peen Marking Tool**

Model	Order code	Shank	Weight kg
TAPWRITER	57820	20 mm	1.7
	57825	25 mm	
	57810	1"	

**(B) Stop Arm Plate Assembly 392552**

Please note a blank stop arm which can be modified is included. Please see torque bars on Pg. 55.

