

- BISON OIL COUNTRY CHUCKS HD with large through-holes are designed for gripping long and heavy workpieces or pipes during heavy-duty (HD) machining
- High gripping force
- High accuracy
- Heavy-duty operations
- Chucks can work individually or in pairs, mounted on opposite sides of the lathe spindle

A [in]	Taper Size	B [in]	C [in]	D [in]	E	F [in]	G [in]	H [in]	I [in]	K [in]	L [in]	N [in]	Clamping range [in]	Torque on wrench [lb/ft]	Gripping force per jaw [lbf]	Max. rpm	Weight [lbs]
16.34	8	5.50	5.35	6.75	4xM16	0.84	5.71	6.07	2.98	0.71	2.44	0.75	1.77 - 16.34	259	7,190	1,200	320
16.34	11	7.75	6.61	9.25	4xM20	1.00	5.71	6.07	2.98	0.71	2.44	0.75	1.77 - 16.34	259	7,190	1,200	302
19.69	11	7.75	6.61	9.25	8xM20	1.00	5.71	6.07	2.98	0.87	2.36	0.75	1.77 - 19.69	259	7,190	1,000	450
19.69	15	11.25	8.07	13.00	8xM24	1.24	5.71	6.07	2.98	0.87	2.36	0.75	1.77 - 19.69	259	7,190	1,000	414
24.80	15	11.25	10.63	13.00	8xM24	1.34	6.10	6.58	3.57	0.87	2.95	0.87	1.97 - 24.80	296	8,320	850	683
24.80	20	16.25	10.63	18.25	8xM24	1.50	6.10	6.58	3.57	0.87	2.95	0.87	1.97 - 24.80	296	8,320	850	650
24.80	20	16.25	12.60	18.25	8xM24	1.50	6.10	6.58	3.57	0.87	2.95	0.87	3.94 - 24.80	296	8,320	850	661
27.95	15	11.25	10.63	13.00	8xM24	1.34	6.10	6.58	3.57	0.87	2.95	0.87	2.95 - 27.95	331	9,217	750	914
27.95	20	16.25	12.60	18.25	8xM24	1.50	6.10	6.58	3.57	0.87	2.95	0.87	3.94 - 27.95	331	9,217	750	870
31.50	15	11.25	10.63	13.00	8xM24	1.34	6.50	6.97	3.57	0.87	2.95	0.87	2.95 - 31.50	331	9,217	600	1,289
31.50	20	16.25	12.60	18.25	8xM24	1.50	6.50	6.97	3.57	0.87	2.95	0.87	4.53 - 31.50	331	9,217	600	1,245
31.50	20	16.25	14.57	18.25	8xM24	1.50	6.50	6.97	3.57	0.87	2.95	0.87	6.10 - 31.50	331	9,217	600	1,201
39.37	28	23.00	20.87	25.50	8xM30	1.53	6.89	7.37	3.57	1.10	2.95	0.87	13.78 - 39.37	368	10,116	430	1,686
49.21	15	11.25	11.06	13.00	8xM24	1.13	6.89	7.37	3.57	1.10	2.95	0.87	3.94 - 49.21	368	11,240	350	3,540

Larger diameters available on page 82-93!

4317 HD

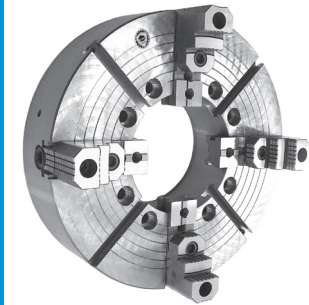

Standard accessories

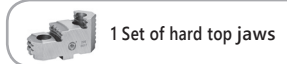

1 Set of hard top jaws



1 Set of hard master jaws



1 Wrench

Spare parts 99-141

Technical data 142-148

Type	Code No.
4317-16"-8-5.3" HD	7-859-1620
4317-16"-11-6.5" HD	7-859-1625
4317-20"-11-6.5" HD	7-859-2033
4317-20"-15-8" HD	7-859-2043
4317-25"-15-10.5" HD	7-859-2543
4317-25"-20-10.5" HD	7-859-2550
4317-25"-20-12.5" HD	7-859-2555
4317-28"-15-10.5" HD	7-859-2845
4317-28"-20-12.5" HD	7-859-2853
4317-32"-15-10.5" HD	7-859-3243
4317-32"-20-12.5" HD	7-859-3255
4317-32"-20-14.5" HD	7-859-3257
4317-40"-28-20.5" HD	7-859-4063
4317-49"-15-11" HD	7-859-4915