

PROPRIETARY AND CONFIDENTIAL  
 THE INFORMATION CONTAINED IN THIS  
 DRAWING IS THE SOLE PROPERTY OF  
 JSB TECH PTE LTD. ANY  
 REPRODUCTION IN PART OR AS A WHOLE  
 WITHOUT THE WRITTEN PERMISSION OF  
 JSB TECH PTE LTD IS  
 PROHIBITED.

		UNLESS OTHERWISE SPECIFIED:	NAME	DATE
		DIMENSIONS ARE IN MM	DRAWN	SOO KUAN
		TOLERANCES:	CHECKED	15/10/12
		FRACTIONAL ±	ENG APPR.	
		ANGULAR: MACH ± BEND ±	MFG APPR.	
		TWO PLACE DECIMAL ±	Q.A.	
		THREE PLACE DECIMAL ±	COMMENTS:	
		INTERPRET GEOMETRIC TOLERANCING PER:		
		MATERIAL PC/ABS CAST IRON		
NEXT ASSY	USED ON	FINISH		
APPLICATION		DO NOT SCALE DRAWING		

ALL DIMENSION IN MM		
TITLE: <b>DWL3500XY</b>		
SIZE <b>A</b>	DWG. NO. <b>2012-10-3103</b>	REV
SCALE: 1:1	WEIGHT:	SHEET 1 OF 2

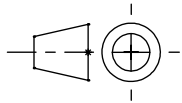
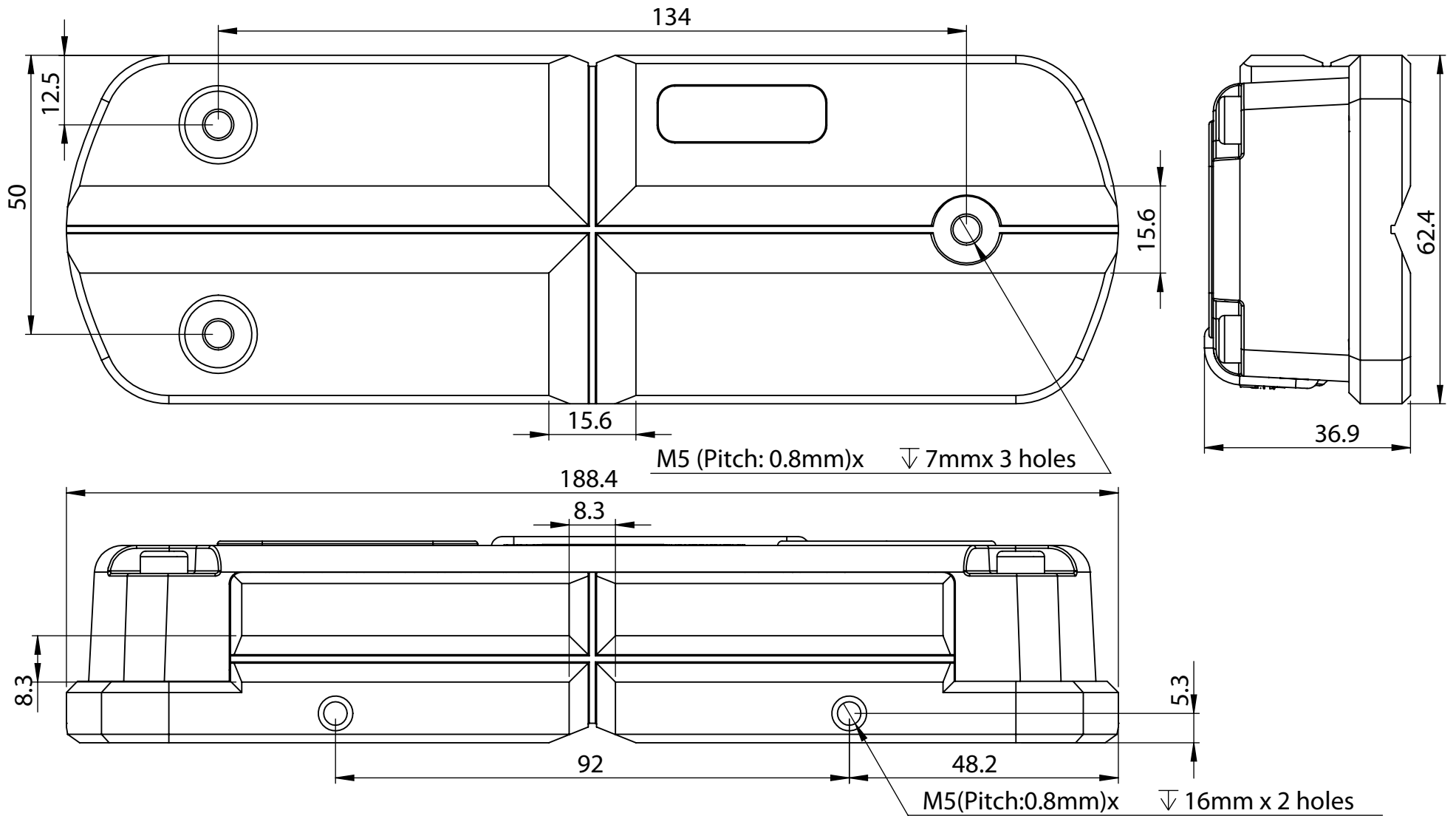

PROPRIETARY AND CONFIDENTIAL  
 THE INFORMATION CONTAINED IN THIS  
 DRAWING IS THE SOLE PROPERTY OF  
 JSB TECH PTE LTD. ANY  
 REPRODUCTION IN PART OR AS A WHOLE  
 WITHOUT THE WRITTEN PERMISSION OF  
 JSB TECH PTE LTD IS  
 PROHIBITED.

		UNLESS OTHERWISE SPECIFIED:		NAME	DATE
		DIMENSIONS ARE IN MM		DRAWN	SOO KUAN 15/10/12
		TOLERANCES:		CHECKED	
		FRACTIONAL $\pm$		ENG APPR.	
		ANGULAR: MACH $\pm$ BEND $\pm$		MFG APPR.	
		TWO PLACE DECIMAL $\pm$		Q.A.	
		THREE PLACE DECIMAL $\pm$		COMMENTS:	
		INTERPRET GEOMETRIC TOLERANCING PER:			
		MATERIAL PC/ABS CAST IRON			
		FINISH			
NEXT ASSY	USED ON				
APPLICATION		DO NOT SCALE DRAWING			

ALL DIMENSION IN MM

TITLE:

**DWL3500XY**

SIZE	DWG. NO.	REV
<b>A</b>	2012-10-3104	

SCALE: 1:1	WEIGHT:	SHEET 2 OF 2
------------	---------	--------------