

- ISO taper shank acc. DIN ISO 7388-2 (formerly JIS B 6339/MAS 403 BT)
- Taper quality AT3
- Concentricity  $\leq 3 \mu\text{m}$  at projection length of 3 x dia.
- Internal coolant supply

## BT

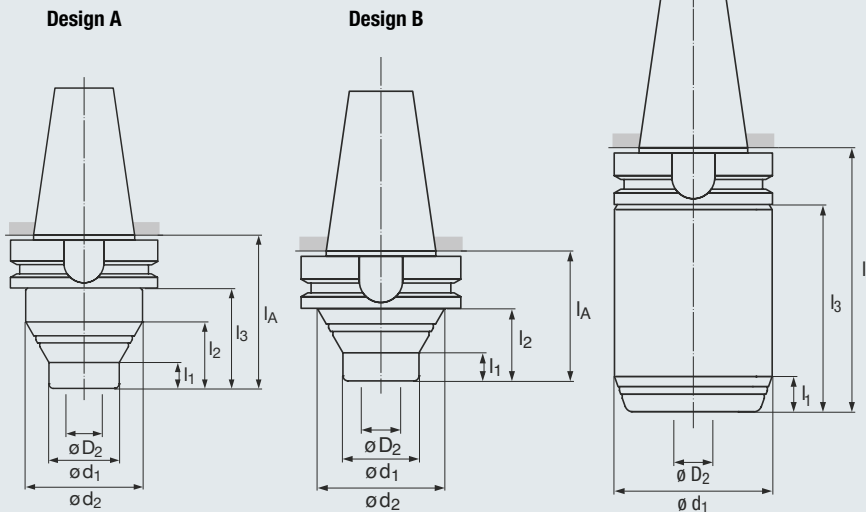
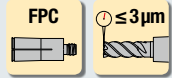

Icon descriptions (see page 11)

### BT30

SIZE	D2 (RANGE)	Design	d <sub>1</sub>	d <sub>2</sub>	l <sub>1</sub>	l <sub>2</sub>	l <sub>3</sub>	l <sub>A</sub>	EDP no.
FPC14	1/8" - 9/16" 2 mm - 14 mm	A	30	53	11	28	56	82	6493.301408
FPC20	1/8" - 3/4" 2 mm - 20 mm	A	40	53	20	31	56	82	6493.302008

### BT40

SIZE	D2 (RANGE)	Design	d <sub>1</sub>	d <sub>2</sub>	l <sub>1</sub>	l <sub>2</sub>	l <sub>3</sub>	l <sub>A</sub>	EDP no.
FPC14	1/8" - 9/16" 2 mm - 14 mm	A	30	50	11	28	43	70	6493.401407
FPC14	1/8" - 9/16" 2 mm - 14 mm	A	30	50	61	78	93	120	6493.401412
FPC14	1/8" - 9/16" 2 mm - 14 mm	A	30	50	85	103	129	156	6493.401415
FPC20	1/8" - 3/4" 2 mm - 20 mm	B	40	63	18	38	-	70	6493.402007
FPC20	1/8" - 3/4" 2 mm - 20 mm	B	40	63	48	68	-	120	6493.402012
FPC20	1/8" - 3/4" 2 mm - 20 mm	B	40	63	84	104	-	156	6493.402015
FPC25	5/8" - 1 1/4" 16 mm - 32 mm	C	63	-	14	-	-	110	6493.402511

### BT50

SIZE	D2 (RANGE)	Design	d <sub>1</sub>	d <sub>2</sub>	l <sub>1</sub>	l <sub>2</sub>	l <sub>3</sub>	l <sub>A</sub>	EDP no.
FPC20	1/8" - 3/4" 2 mm - 20 mm	A	40	63	18	38	43	81	6493.502008
FPC20	1/8" - 3/4" 2 mm - 20 mm	A	40	63	84	104	129	167	6493.502016
FPC25	5/8" - 1 1/4" 16 mm - 32 mm	C	70	-	15	-	83	121	6493.502512

Pull studs available upon request