

- Taper shank acc. ASME B5.50-2009
- Taper quality AT3
- Concentricity  $\leq 3 \mu\text{m}$  at projection length of 3 x dia.
- Internal coolant supply

**CAT**

FPC  $\leq 3 \mu\text{m}$

AT3 G2,5  
20000min<sup>-1</sup>

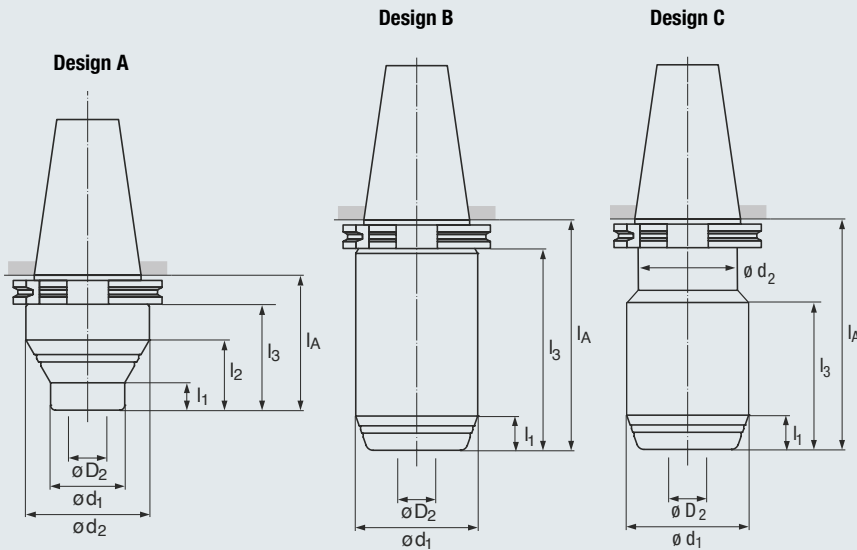

Icon descriptions (see page 11)

### CAT 40

SIZE	D2 (RANGE)	Design	d <sub>1</sub>	d <sub>2</sub>	l <sub>1</sub>	l <sub>2</sub>	l <sub>3</sub>	l <sub>A</sub>	EDP no.	
FPC14	1/8" - 9/16"	2 mm - 14 mm	A	30	50	11	28	43	62	6494.401406
FPC14	1/8" - 9/16"	2 mm - 14 mm	A	30	50	61	78	93	112	6494.401411
FPC14	1/8" - 9/16"	2 mm - 14 mm	A	30	50	85	103	129	148	6494.401414
FPC20	1/8" - 3/4"	2 mm - 20 mm	A	40	50	20	28	43	62	6494.402006
FPC20	1/8" - 3/4"	2 mm - 20 mm	A	40	50	69	78	93	112	6494.402011
FPC20	1/8" - 3/4"	2 mm - 20 mm	A	40	50	94	103	129	149	6494.402014
FPC25	5/8" - 1 1/4"	16 mm - 32 mm	C	63	50	14	-	61	102	6494.402510

### CAT 50

SIZE	D2 (RANGE)	Design	d <sub>1</sub>	d <sub>2</sub>	l <sub>1</sub>	l <sub>2</sub>	l <sub>3</sub>	l <sub>A</sub>	EDP no.	
FPC20	1/8" - 3/4"	2 mm - 20 mm	A	40	63	18	38	43	62	6494.502006
FPC20	1/8" - 3/4"	2 mm - 20 mm	A	40	63	84	104	129	149	6494.502014
FPC25	5/8" - 1 1/4"	16 mm - 32 mm	B	70	-	15	-	83	102	6494.502510