



EXTRA CAPACITY 6" XL VISES



Hydraulic Reverse Version

Manual Version

Kurt XL vises are designed for precision clamping of very large parts for both tool and die and production CNC applications. With up to a 28.750" jaw opening, these vises lock precisely, even for high horsepower "hogging out" operations. All sides of Kurt XL vises are accurate to within 0.001" for precise, easy alignment in multiples. XL vises may be mounted and used as receivers for other workholding devices.

Features:

- Up to 12,000 lbs. precision clamping force.
- AngLock design reduces jaw lift.
- 80,000-PSI ductile iron body.
- 6" and 8" jaw widths with jaw openings from 0"-21" with a maximum of 28.765" (in the outside jaw positions).
- "Pull-Type" clamping means high precision and repeatability.
- Great for high horsepower "hogging out" applications.
- Reverse model reduces "reach-over" distance making part loading safer and easier for the operator. Also part programming is easier in the "Y" axis positive direction.
- Manual, air and hydraulic models available.
- Air and hydraulic feature a 1/4" stroke.
- Air power option provides a precise and repeatable "gentle touch" for delicate parts.
- Internal hex screw available.

VISE CLAMPING FORCE-LBS.		
Manual Torque Ft.-Lbs.	Manual	
	640XLS	640XLR
10	989	989
20	1,768	1,768
30	2,586	2,586
40	3,731	3,731
50	4,398	4,398
60	5,785	5,785
70	6,235	6,235
80	6,877	6,877

VISE CLAMPING FORCE-LBS.		
Hydraulic PSI	Hydraulic	
	640XLHS	640XLHR
400	1,575	1,575
800	3,150	3,150
1,200	4,725	4,725
1,600	6,300	6,300
2,000	7,875	7,875
2,400	9,450	9,450
2,800	11,025	11,025
3,200	12,600	12,600

VISE CLAMPING FORCE-LBS.		
AIR PSI	Air	
	640XLAS	640XLAR
10	320	320
20	840	840
30	1,280	1,280
40	1,780	1,780
50	2,200	2,200
60	2,720	2,720
70	3,240	3,240
80	3,800	3,800
90	4,380	4,380
100	5,000	5,000



EXTRA CAPACITY 8" XL VISES

Model:
8XL

Standard (S)

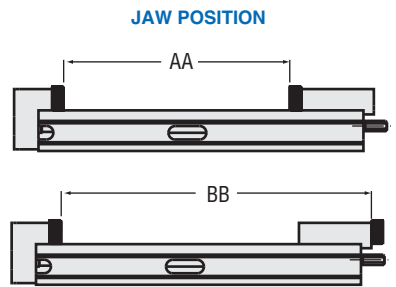
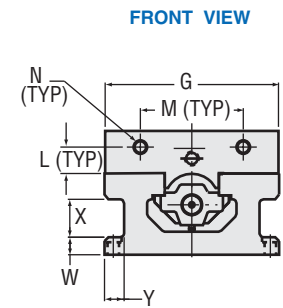
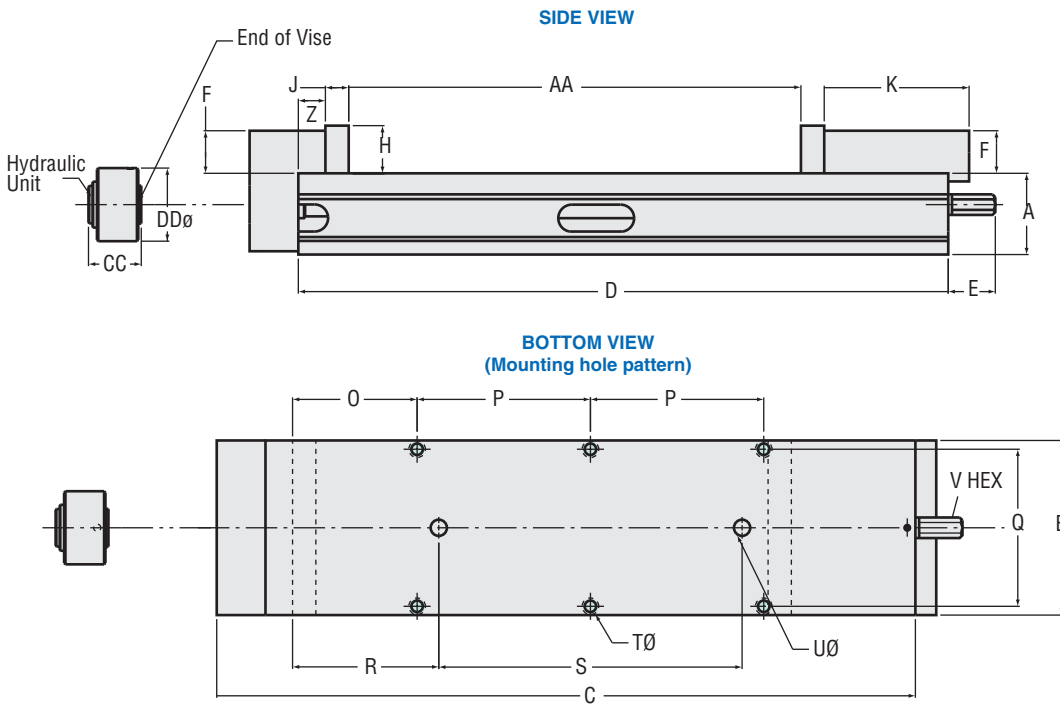

Reverse (R)

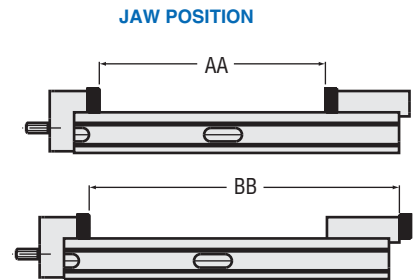
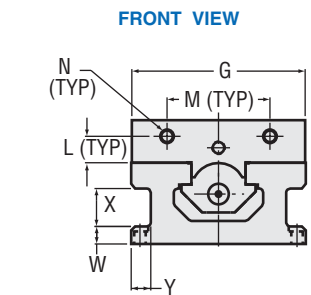
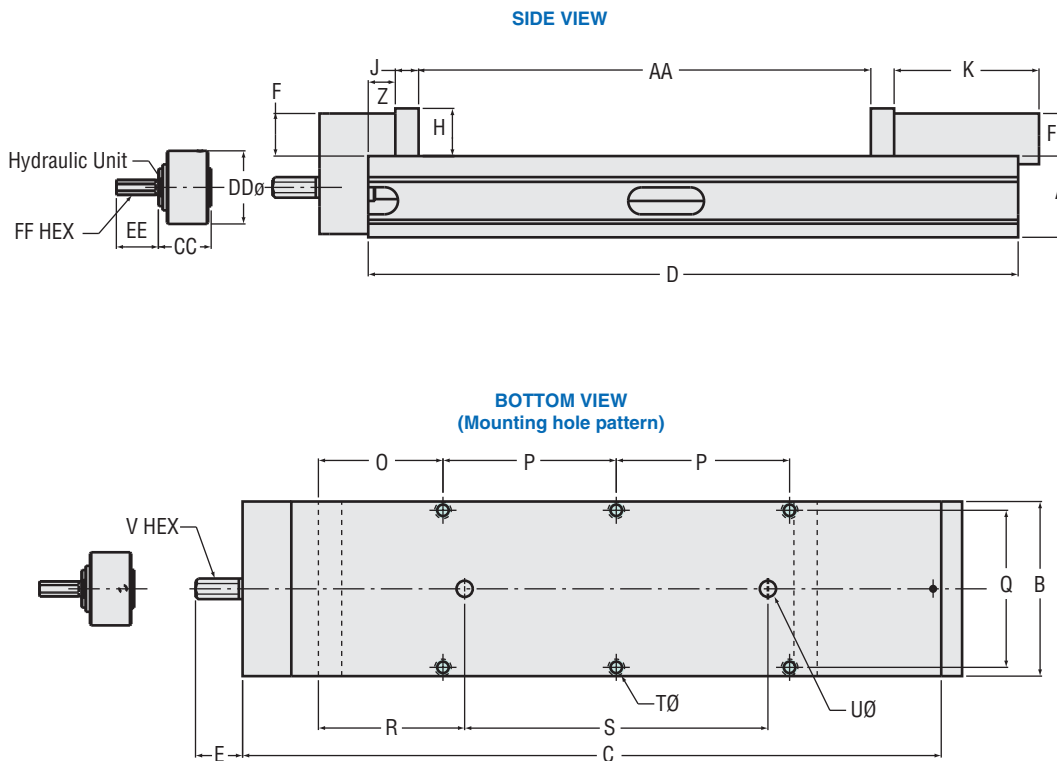

Note: Keyway slots can be machined in.
Call CEW group for quotation 1-877-226-7823

EXTRA CAPACITY 8" XL VISES

VISE CLAMPING FORCE-LBS.		
Hydraulic PSI	Hydraulic	
	8XLPTLSHS	8XLPTLSHR
1,400	5,600	5,600
1,800	7,490	7,490
2,200	8,765	8,765
2,800	11,250	11,250
3,000	12,050	12,050
3,200	12,780	12,780

VISE CLAMPING FORCE-LBS.		
Manual Torque Ft.-Lbs.	Manual	
	8XLPTLSS	8XLPTLSR
20	2,904	2,904
40	5,664	5,664
60	7,872	7,872
80	10,824	10,824
100	13,848	13,848
120	16,632	16,632
140	19,008	19,008
160	20,376	20,376

DIMENSIONAL DATA				
	Manual		Hydraulic	
	8XLPTLSS	8XLPTLSR	8XLPTLSHS	8XLPTLSHR
A	3.750	3.750	3.750	3.750
B	8.060	8.060	8.060	8.060
C	32.250	32.250	32.250	32.250
D	30.000	30.000	30.000	30.000
E	2.170	1.890	2.160	-
F	1.965	1.965	1.965	1.965
G	8.000	8.000	8.000	8.000
H	2.200	2.200	2.200	2.200
J	1.075	1.075	1.075	1.075
K	6.690	6.690	6.690	6.690
L	1.220	1.220	1.220	1.220
M	4.750	4.750	4.750	4.750
N	5/8-11	5/8-11	5/8-11	5/8-11
O	5.750	5.750	5.750	5.750
P	8.000	8.000	8.000	8.000
Q	7.250	7.250	7.250	7.250
R	6.750	6.750	6.750	6.750
S	14.000	14.000	14.000	14.000
T	1/2	1/2	1/2	1/2
U	0.750	0.750	0.750	0.750
V	7/8	3/4	7/8	-
W	0.810	0.810	0.810	0.810
X	1.750	1.750	1.750	1.750
Y	0.900	0.900	0.900	0.900
Z	1.250	1.250	1.250	1.250
AA	21.000	21.000	21.000	21.000
BB	28.765	28.765	28.765	28.765
CC	-	-	2.400	2.400
DD	-	-	3.375	3.375
EE	-	-	-	1.940
FF	-	-	-	5/8
Ship Wt. Lbs.	230	235	230	235
Hydraulic Displacement cu. In.	-	-	1.18	1.18

