

**mijin** system

Spring Balancer

# TIGON

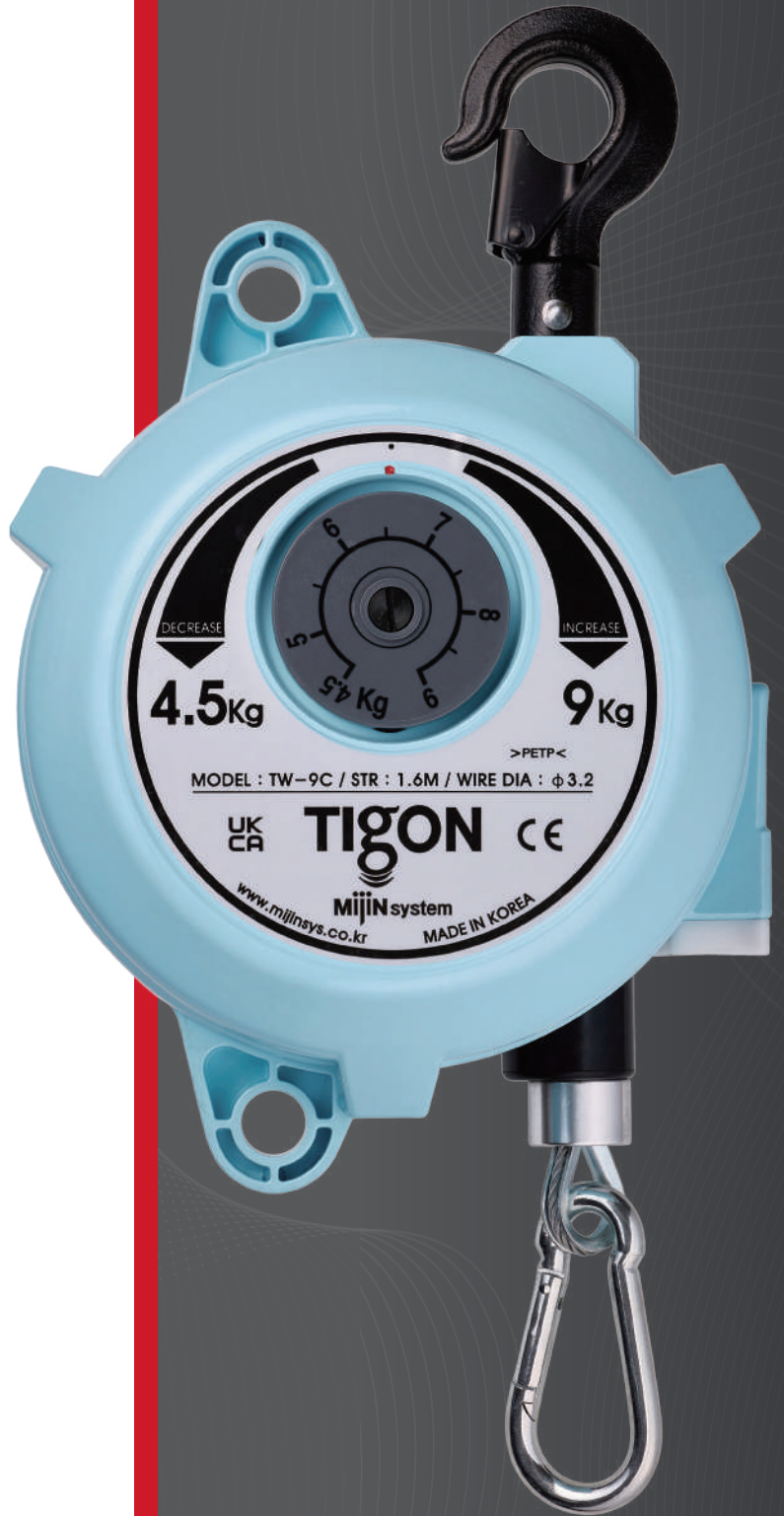



Mijin system is a manufacturer of industrial tools.  
We are doing our best to meet our customers' expectation  
with best price and perfect qualities Since 1976

# TIGON BALANCER

Featuring the Tool Balancer

## Zero Gravity Spring Balancer

MIJIN SYSTEM Inc.'s TIGON Spring Balancers improve working efficiency and diminish worker fatigue and make the position of a tool stable and contribute to accurate work. So the balancers are available for keeping a tool not damaged. Any electric or pneumatic power is not required and safe working is achieved. TIGON Spring Balancer provides by the Company improves work safety and efficiency capacities ranging from 0.2 ~120 Kg (1.1~264lbs)

# Spring Balancer

TW-00 / TW-0

# TIGON



**TW-00**

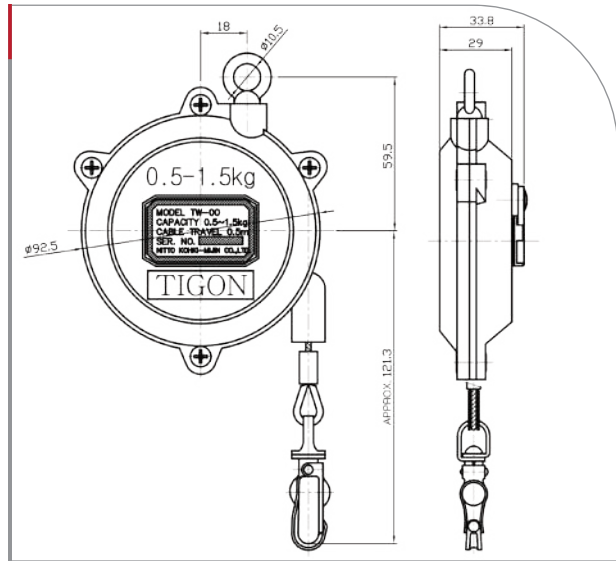

**TW-0**

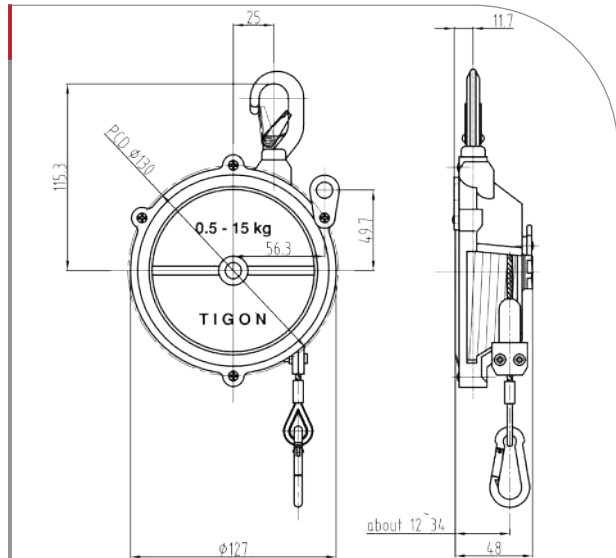

**Light Weight**  
Suitable for the light weight tool



**Efficiency**  
Improve work efficiency

## • Specification

Clasify	TW - 00	TW - 0
Capacity (Kg / lb)	0.5~1.5 / 1.1~3.3	0.5~1.5 / 1.1~3.3
Stroke ( m/ ft )	0.5 / 1.64	1 / 3.28
Wire diameter (mm)	2	3.18
Weight (Kg / lb)	0.2 / 0.44	0.5 / 1.1



**TIGON**

# Spring Balancer

TW-3C / TW-5C / TW-6.5C

**TW-3C/5C/6.5C**

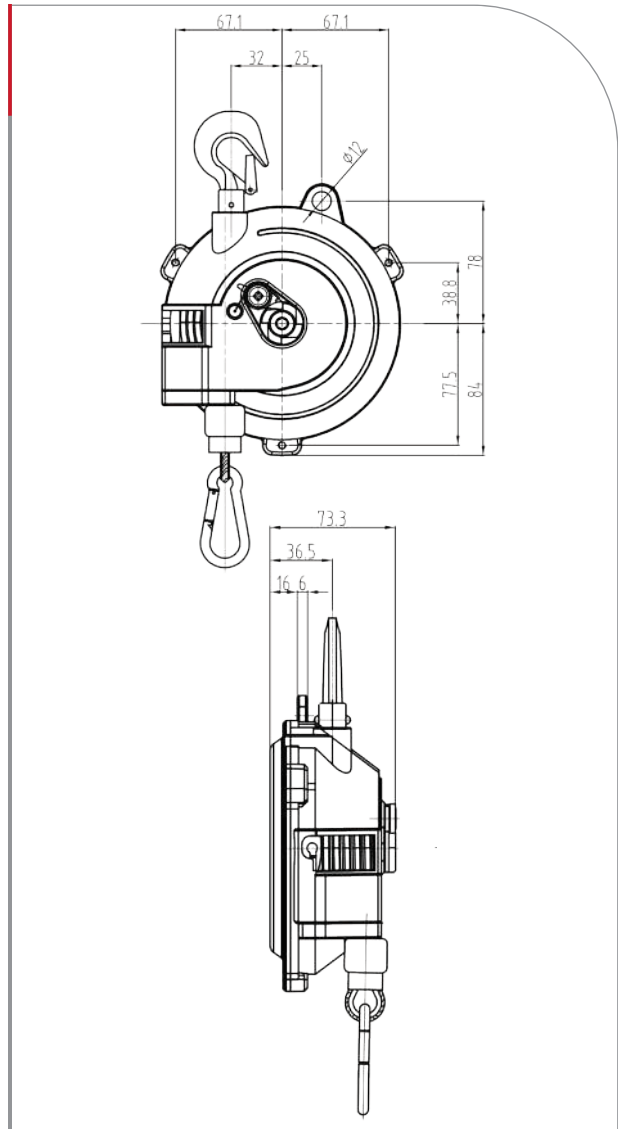
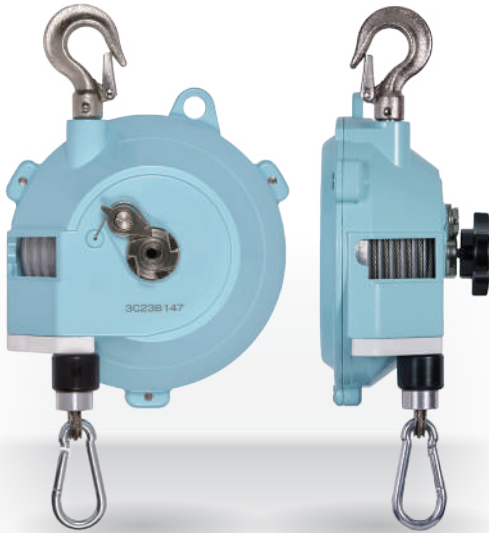

**Safety**  
minimize the open part



**Working range**  
longer stroke for working range



**Easy to use**  
combined use for Knob & L wrench



**Durability**  
cable insert guide for case & wire Stainless plating for corrosion resistance

## • Specification

Clasify	TW-3C	TW-5C	TW-6.5C
Capacity (Kg / lb)	1.0~3.0 / 2.2~6.6	2.5~5.0 / 5.5~11.0	4.0~6.5 / 8.8~14.3
Stroke ( m/ ft )	1.7 / 5.57	1.7 / 5.57	1.7 / 5.57
Wire diameter (mm)	2.38	2.38	2.38
Weight (Kg / lb)	1.7 / 3.74	1.8 / 3.96	1.9 / 4.18

# Spring Balancer

TW-9C / TW-15C

# TIGON



**TW-9C/15C**

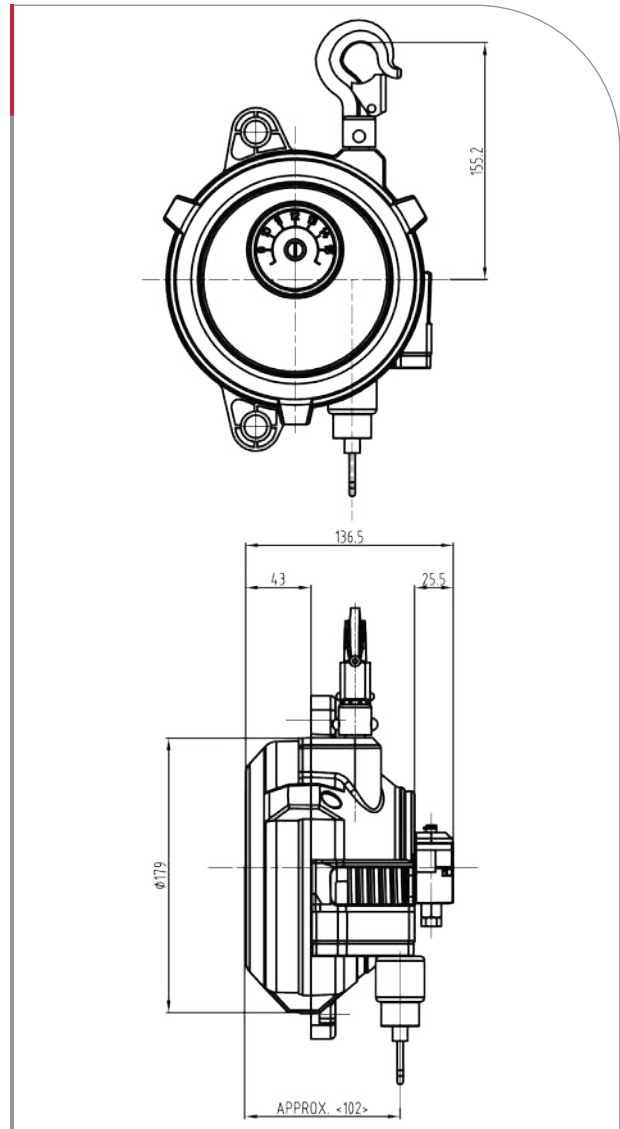
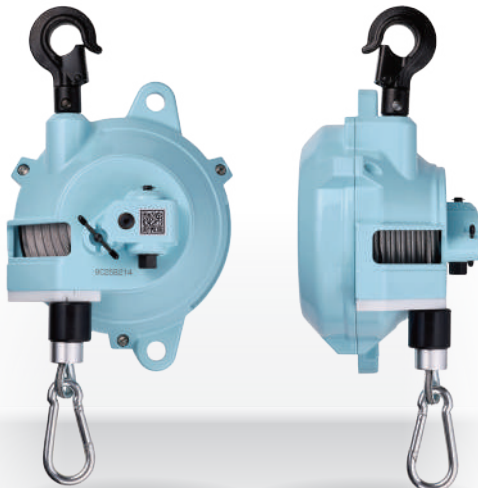

**Popularity**  
Popular Middle Weight



**Safety**  
double safety feature for workers safety

## • Specification

Clasify	TW - 9C	TW - 15C
Capacity (Kg / lb)	4.5~9.0 / 9.92~19.84	9.0~15.0 / 19.84~33.06
Stroke ( m/ ft )	1.6 / 5.24	1.6 / 5.24
Wire diameter (mm)	3.2	3.2
Weight (Kg / lb)	3.7 / 8.15	4 / 8.81



**TIGON**

# Spring Balancer

TW(L)-22 / TW(L)-30

**TW(L)-22/30**

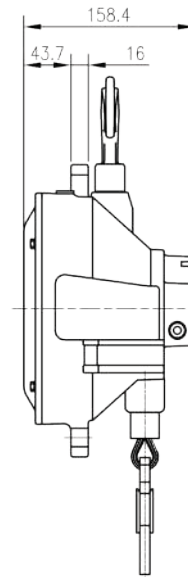
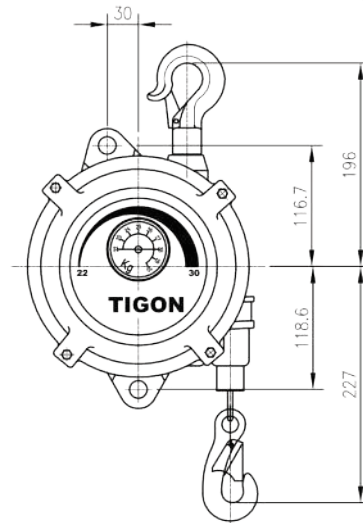

**Safety**  
double safety feature  
for workers safety



**Popularity**  
Popular Middle  
Weight



**Stroke Option**  
2 stroke types for  
working environment

## • Specification

Clasify	TW-22 TWL-22	TW-30 TWL-30
Capacity (Kg / lb)	15~22.0 / 33.06~48.50	22.0~30.0 / 48.50~66.13
Stroke ( m/ ft )	1.5 / 4.92	1.5 / 4.92
	2.1 / 6.89	2.1 / 6.89
Wire diameter (mm)	4.76	4.76
Weight (Kg / lb)	7.2 / 15.87	7.6 / 16.75

# Spring Balancer

TW(L)-40/50, TW(L)-60/70/80

# TIGON



**TW(L)-40/50**

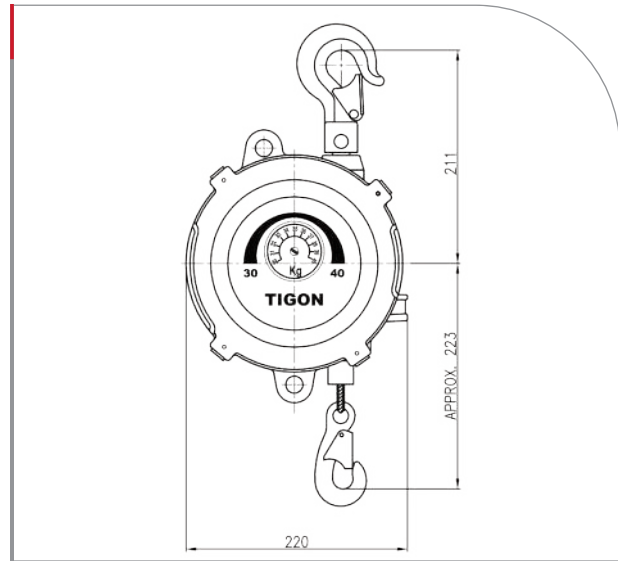

**TW(L)-60/70/80**

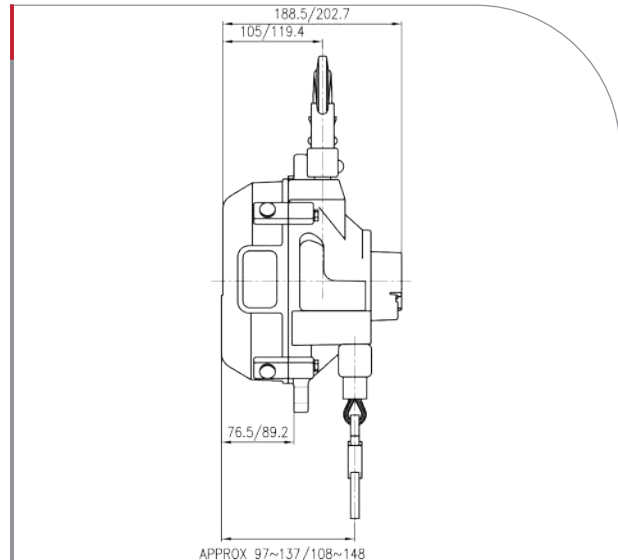

**Safety**  
double safety feature  
for workers safety



**Popularity**  
Popular Middle  
Weight



**Stroke Option**  
2 stroke types for  
working environment

## • Specification

Clasify	TW-40 TWL-40	TW-50 TWL-50	TW-60 TWL-60	TW-70 TWL-70	TW-80 TWL-80
Capacity (Kg / lb)	30.0~40.0 / 66.13~88.18	40.0~50.0 / 88.18~110.23	50.0~60.0 / 110.23~132.27	60.0~70.0 / 132.27~154.32	70.0~80.0 / 154.32~176.37
Stroke ( m / ft )	1.5 / 4.92	1.5 / 4.92	1.5 / 4.92	1.5 / 4.92	1.5 / 4.92
	2.1 / 6.89	2.1 / 6.89	2.1 / 6.89	2.1 / 6.89	2.1 / 6.89
Wire diameter (mm)	4.76	4.76	4.76	4.76	4.76
Weight (Kg / lb)	9.8 / 21.60	10.4 / 22.92	11.6 / 25.57	11.8 / 26.01	12 / 26.45



TW-90/105/120

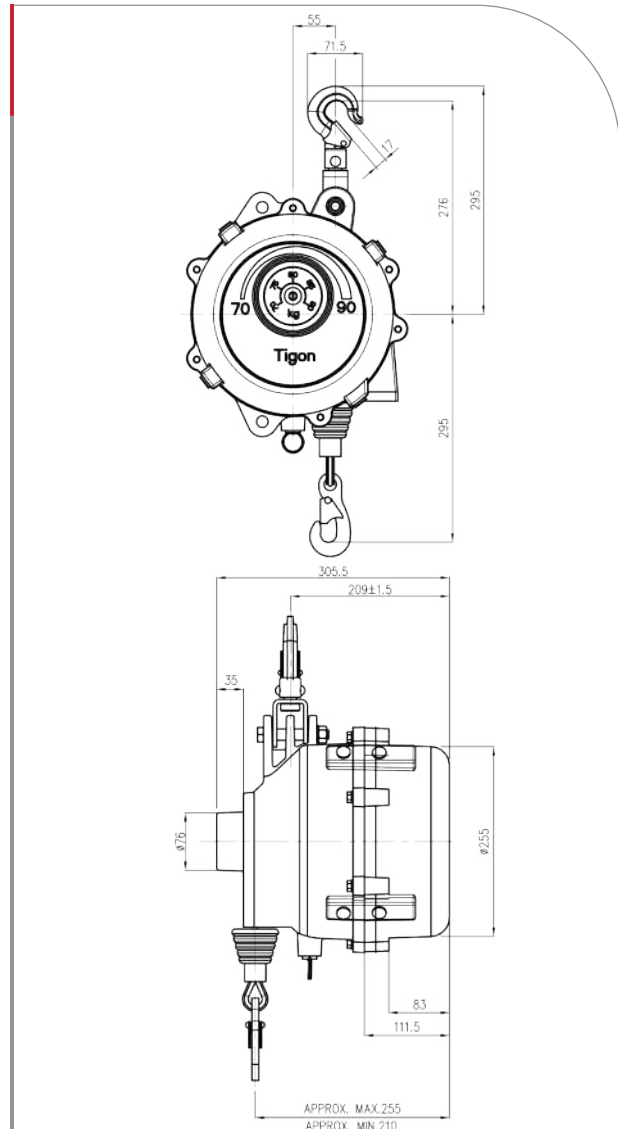

### Heavy Weight

Suitable for the heavy weight tool



### Efficiency

Improve work efficiency

### • Specification

Clasify	TW-90	TW-105	TW-120
Capacity (Kg / lb)	70-90 / 158.73~198.41	85-105 / 187.39~231.48	100-120 / 220.46~264.55
Stroke ( m/ ft )	2.1 / 6.89	2.1 / 6.89	2.1 / 6.89
Wire diameter (mm)	4.76	4.76	4.76
Weight (Kg / lb)	27 / 59.52	29 / 63.93	30 / 66.13

# Retractor

# TIGON

RW-0 / RW-3 / RW-5 , TW-06R / TW-1R / TW-2R

**RW-0/3/5**

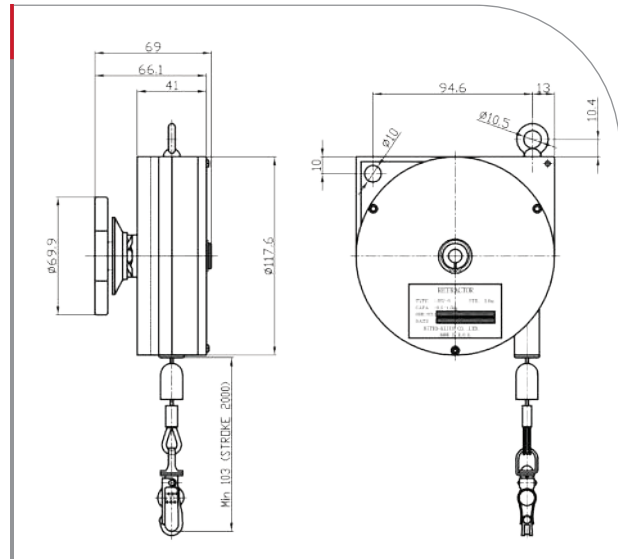

**TW-06R/1R/2R**

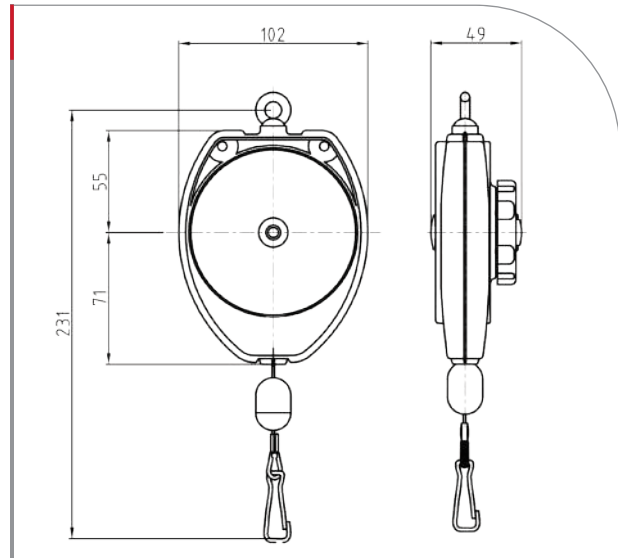

**Light Weight**  
Suitable for the light weight tool



**Efficiency**  
Improve work efficiency



**Easy to use**  
Using Knob for tension adjustment

## • Specification

Clasify	RW-0	RW-3	RW-5	TW-06R	TW-1R	TW-2R
Capacity (Kg / lb)	0.5-1.5 / 1.10~3.30	1.0-3.0 / 2.20~6.60	2.5-5.0 / 5.51~11.02	0.2-0.6 / 0.44~1.32	0.5-1.5 / 1.10~3.30	1.0-2.0 / 2.20~4.40
Stroke ( m/ ft )	2 / 6.56	2 / 6.56	2 / 6.56	1.5 / 4.92	1.5 / 4.92	1.5 / 4.92
Weight (Kg / lb)	0.5 / 1.10	0.7 / 1.54	0.9 / 1.98	0.3 / 0.66	0.3 / 0.66	0.3 / 0.66



**HW-0/3/5**

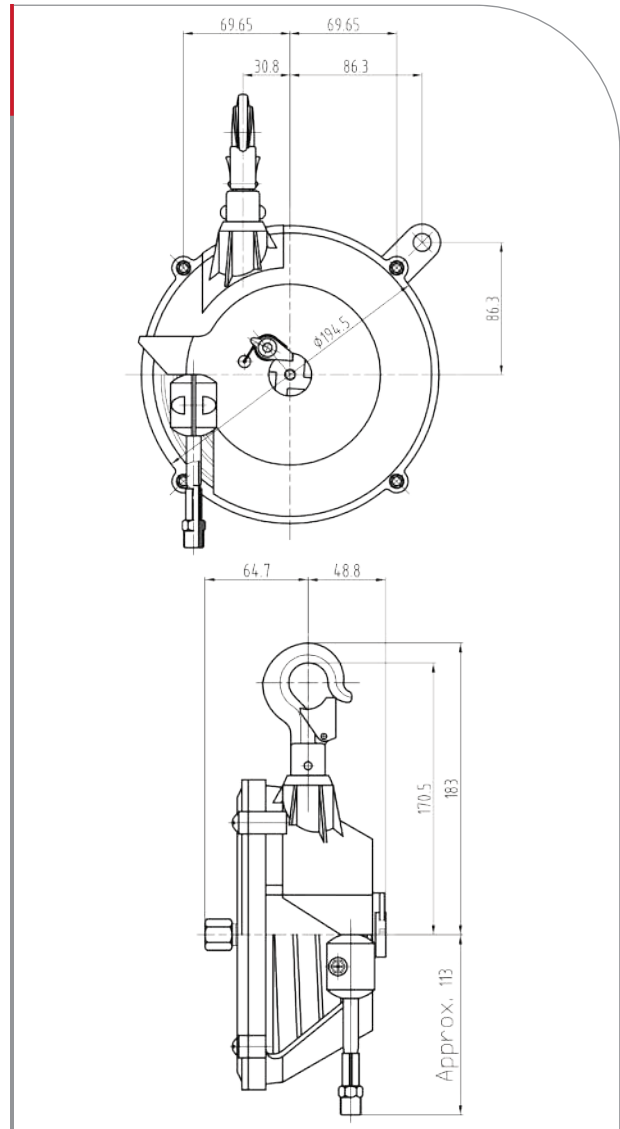

**Optimization**  
Optimized for Air tools



**Efficiency**  
Improve work efficiency

• **Specification**

Clasify	HW-0	HW-3	HW-5
Capacity (Kg / lb)	0.5-1.5 / 1.10~3.30	1.5-3.0 / 3.30~6.60	3.0-5.0 / 6.60~11.02
Stroke ( m/ ft )	1.3 / 4.26	1.3 / 4.26	1.3 / 4.26
Hose diameter (Ømm)	Ø6.5	Ø6.5	Ø6.5
Weight (Kg / lb)	1.6 / 3.52	1.7 / 3.74	1.8 / 3.96



## Air Reel



### • Specification

Hose Material : Poly-Urethane/ Poly-Propylene  
 Max Pressure: 15kgf/cm<sup>2</sup>  
 Max Temperature: 50°C  
 Available Hose: ID Ø6 ~Ø11  
 Application  
 Air Service & Tools  
 Assembly Operations  
 Manufacturing Plants & Facilities  
 Maintenance, Repair & Operations  
 Automotive & Fleet Service Centers  
 Painting : Power Coating

## Water Reel



### • Specification

Hose Material : PVC Synthetics  
 Max Pressure : 10kgf/cm<sup>2</sup>  
 Max Temperature: 70°C  
 Design & Structure  
 Reels are all stainless steel construction with strong corrosion resistance  
 Dual frame, guide plate & ball bearing support  
 Special heat-treatment spring & non-corrosive ratchet  
 Wide usage with 120 degree swing  
 Inlet & outlet connection threads are female NPT

## High Pressure Reel



### • Specification

Available Hose: 1/4 inch~1 inch  
 Hose capacity : 165FT / 50 MR  
 Max Pressure: 2900psi/200bar  
 Max Temperature : 212°F (100°C)  
 Hose  
 Low pressure hose reels are furnished standard with PVC  
 Medium pressure hose reels are furnished standard with S.A.E 100R1 type at wire braid hose  
 High pressure hose reels are furnished standard S.A.E 100R2 type at two wire braid hose  
 other specifications are available



**Special order**  
 custom-made product for various working environment



**Easy to use**  
 custom-made product for Easy-to-use

### • Custom made available





# 3mm Micro Grinder

MGM-103S

**MGM - 103S**



Optimized products for various types of precision grinding

Small and lightweight designed product considering long-time machining work as much as possible

Products capable of stepless speed change function (0~65,000 Rpm)

• **Specification**

Model	Air Pressure	Air Consumption	No-load Speed	Collet Size	Air Supply Screw	Weight
Unit	kgf/cm <sup>2</sup>	m <sup>3</sup> /min	min <sup>-1</sup>	mm		Kg
MGM-103S	6	0.2	60,000	3	PT1/4	0.13

• **Packing detail**

Model	Main Body	Standard Accessories
MGM-103S	1 EA	Air Hose : 1SET , DUST FILTER : 2EA , HOSE BAND : 2EA , HOSE JOINT : 1EA , SET PIN : 1EA , SPANNER : 1EA

• **Spring Balancer Used in Various industrial field**





• Basic structure and Features

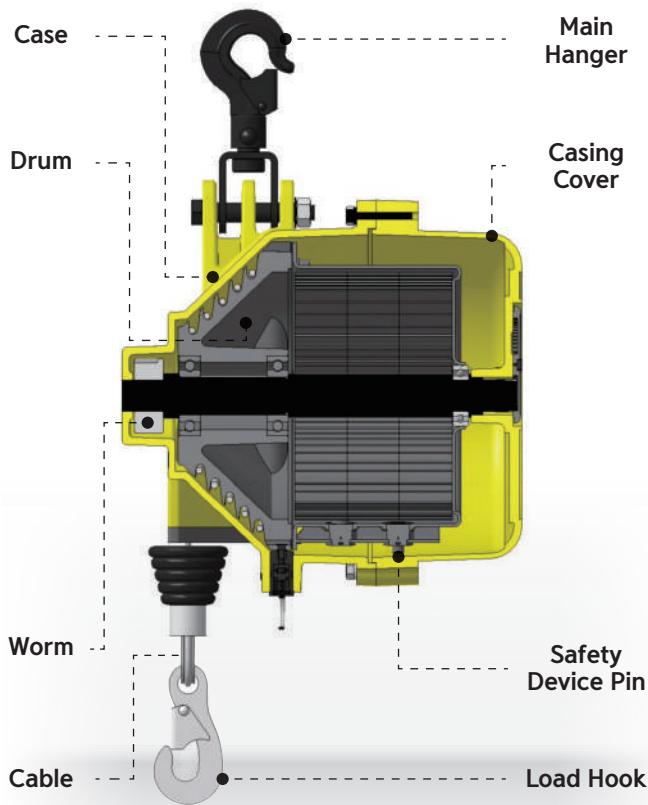

Fall arrest device

When spring is broken, safety pin pops out and collides with pin fixed or case to prevent the suspended tools from falling



Drum lock device

You can lock the drum easily and safely when you need to change the tools or wire rope

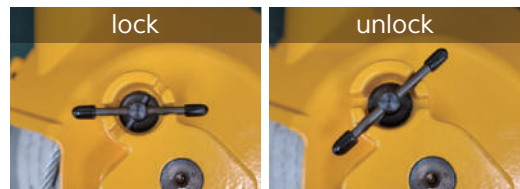

Secondary support hanger

The secondary support hanger is available on every model

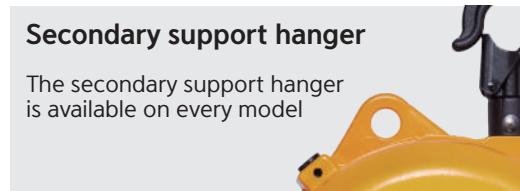

Gauge

The Gauge indication contributes to worker recognition on tension adjustment



• Adjusting Spring tension



• Quality Control and Special order product response



# TIGON Mijin Spring Balancer improves Work safety & Efficiency

## Overseas market

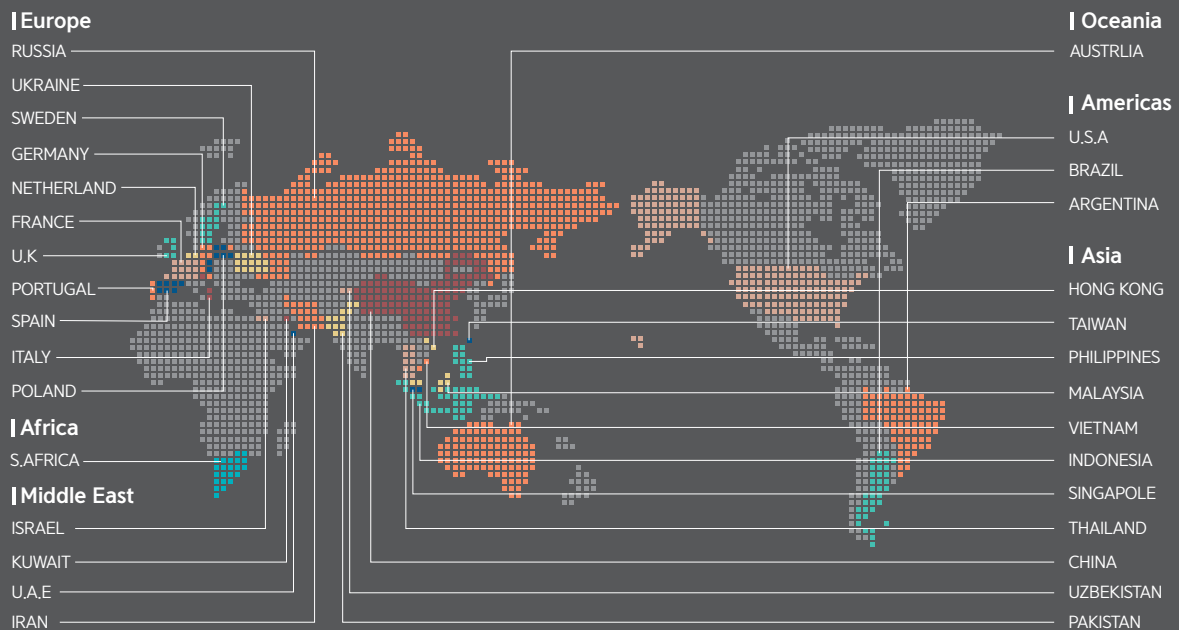

**Mijin system** [www.mijinsys.co.kr](http://www.mijinsys.co.kr)

### Head Office

6,Jungbu-daero 2565beon-gil, Yangji-myeon, Cheoin-gu Yongin-si, Gyeonggi-do, 17162, Korea  
 Tel: +82-31-335-8787 Fax: +82-31-336-0821 E-mail: overseas@mijinsys.co.kr



미진시스템 홈페이지  
[www.mijinsys.co.kr](http://www.mijinsys.co.kr)



미진시스템 쇼핑몰  
[www.mijin-mall.co.kr](http://www.mijin-mall.co.kr)



CE mark  
 ISO 9001