

Model TM-394 Torque Multiplier

1. INTRODUCTION

This handbook covers operation and service instructions for the model TM-394 torque multiplier.



WARNINGS

- To prevent accidental torque release, which could result in personal injury, the neutral positioning set screw (Fig. 2, Item 2) must be flush with the top of the housing whenever the torque multiplier is operated **MANUALLY**. The selector pawl (Fig. 2, Item 3) must also operate freely in the CW and CCW positions.
- Never** strike the selector pawl (Fig. 2, Item 3) to release wrench tension or to change directions. Serious personal injury could result. Internal damage to wrench may occur.
- Inspect output square drive (Fig. 3, Item 4) for visible sign of fatigue or fracture prior to **EACH** use. Replace if necessary (see Section 8).
- Failure of the output square drive, due to torque overload or fatigue, could result in an immediate torque release, potentially causing the torque multiplier to fall from the fastener, and result in personal injury.
- Do Not** hold torque multiplier (Fig. 3, Item 3) or reaction plate (Fig. 3, Item 1) while applying torque since normal multiplier deflection might cause fingers to be pinched; especially in confined locations.
- Always** Maintain firm hand control of torque wrench or input handle when releasing multiplier, since recoil (wind-up) will be experienced.
- The torque multiplier **requires** a special double ended reaction plate (not included), if an output drive extension is used. This type of use, without a double ended reaction anchor, could cause the torque multiplier to be forced sideways on the application, breaking the multiplier and/or socket, and possibly causing personal injury.
- Never** use air or hand driven impact tools with the torque multiplier. Damage to tool could occur.
- Since reaction torque equals **OUTPUT** torque, be sure to select an anchor point sufficient to withstand the torque reaction forces created.
- Check reaction plate holding screws (Fig. 3, Item 2) periodically to insure they are tight.

2. IMPORTANT INSTRUCTIONS

- Read and understand these operating instructions before using the Torque Multiplier.
- If using a POWER driven input, be sure the selector pawl (Fig. 2, Item 3) has been locked into its neutral position using the neutral positioning set screw (Fig. 2, Item 2).
- When positioning the torque multiplier, be sure socket attached to the output is positioned so that the reaction plate is at a right angle to the fastener. Torque reaction creates a rotational force in the opposite direction from which input force is applied. See [Torque Multiplier Application Tips](#) for additional torque multiplier reaction information.
- Remember:** Breakout torque can be much greater than the make up torque value. Be sure that the multiplier being used has sufficient capacity for torque breakout. Allow a minimum of 50% additional capacity in the tool for breakaway torque.

Damaged and corroded fasteners can require even greater breakaway torque capacity.

- When using the torque multiplier without a torque wrench to monitor input torque, remember that the **output torque** is significantly greater than the applied **input torque**. Do not apply more torque than the application can withstand.
- Use only Williams approved output square drives and replacement parts.

3. DESCRIPTION AND DESIGN FEATURES

- The TM-394 torque multiplier uses a planetary geared action to tighten and loosen nuts, bolts and cap screws with a continuous 360° rotation in either clockwise or counterclockwise direction. Input and output rotation directions are the same. (EXAMPLE: Clockwise input rotation creates clockwise output rotation) An internal, two-directional anti-backlash device inhibits accidental torque wind-up release.
- A controlled-shear output square drive (Fig. 3, Item 4) protects internal components in the event maximum output capacity is exceeded. This overload-protection feature causes the drive to fracture when output exceeds from 3% to 10% of rated output capacity. One replacement drive is included with the torque multiplier. Additional replacements can be ordered from your distributor.
- The selector pawl (Fig. 2, Item 3) controls the torque multiplier's rotational direction for manually-applied input. It can also be set in a neutral position for power drive unit torque applications.

4. SPECIFICATIONS

Output Capacity Lbf-ft (N-m)	5,000 (6,779)
Input Capacity Lbf-ft (N-m)	189 (256)
Gear Ratio	29.25:1
Torque Ratio	26.5:1
Accuracy	±5% of reading from 20% to 100% of full-scale rating
Output Drive Male Square Size Inch (mm)	1.5 (38)
Input Drive Female Square Size Inch (mm)	1/2 (13)
Overall Dimensions Inch (mm)	Length (A): 14.88 (378) Gearbox Ø (B): 5.63 (143) Height: (C) 8.75 (222)
Net Weight Lb. (kg)	34 (15.4)
Planetary Gearing Stages	Two
Needle Bearings	Yes
Angle-of-turn Protractor	No
Torque Conversion Chart	Yes
Shearable Replaceable Output Drive	Yes
Reaction Anchor Type	Plate

5. TORQUE CONVERSIONS

- A data plate is attached to the torque multiplier which displays the input torque required to obtain the listed output torque values. If you wish to calculate a specific input value that isn't listed on the attached chart, divide the desired output torque by the multiplier's torque ratio (26.5) to

determine the input torque required (e.g. 2650 Lbf-ft output torque ÷ 26.5 torque ratio = 100 Lbf-ft input torque).

6. MANUAL OPERATION

- 6.1 For manually applied input torque: Set the desired rotation direction by pushing the selector pawl (Fig. 2, Item 3) in the direction indicated by the letters and directional arrows stamped on the input end case (Fig. 2, Item 1). EXAMPLE: If counter-clockwise rotation is desired, push pawl to end of travel in the direction shown by the "CCW" arrow. For clockwise rotation, push pawl in the opposite direction. (See **▲ Warnings**)
- 6.2 Mount the proper size square female drive socket onto the torque multiplier's output square drive (Fig. 3, Item 4), then position socket and torque multiplier on the fastener to be tightened.
- 6.3 Place a socket on the slave square drive and attach it to an adjacent fastener, or butt the reaction anchor plate securely against a suitable object. **Remember:** When socket is properly positioned on fastener, reaction anchor plate must be at right angles to the fastener to which torque is being applied. See [Torque Multiplier Application Tips](#) for additional torque reaction information.
- 6.4 To tighten manually with torque wrench: Determine the input torque required to obtain the desired output by referring to the torque data plate attached to the torque multiplier's reaction anchor plate. Output torque accuracy requires the use of an accurate torque wrench in series with the torque multiplier.
- 6.5 Failure of the output square drive, due to torque overload or fatigue, could result in an immediate torque release, potentially causing the torque multiplier to fall from the fastener, and result in personal injury. (See **▲ Warnings**)
- 6.6 Apply torque with torque wrench until desired input torque is achieved. **To remove torque multiplier from fastener:** Apply enough input torque to release internal anti-backlash device, then push selector pawl (Fig. 2, Item 3) into opposite position (EXAMPLE: If selector pawl is in the clockwise CW position for tightening, apply input torque in the CW direction to relieve force on the pawl. While maintaining input torque in the CW direction, slide pawl into the CCW direction for release) and slowly relax input torque. Never strike selector pawl to release or change directions. (See **▲ Warnings**)
- 6.7 To Loosen: Follow same procedure as for tightening except set the selector pawl in opposite position. (EXAMPLE: If fastener requires clockwise tightening rotation, set pawl in counter-clockwise position for loosening.)

7. PNEUMATIC OPERATION

- 7.1 If you decide to use a **non-impact** power drive to speed up the process of tightening or loosening fasteners, you **MUST** remember to lock the selector pawl in the neutral position. Center the selector pawl (Fig. 2, Item 3) between the CW/CCW range of the travel and tighten the setscrew (Fig. 2, Item 2). When properly positioned, the screw will be seated in a groove in the selector pawl, so the pawl cannot be moved in either direction. Take care that the power drive is set to deliver no more than the maximum allowable input torque. See [Torque Multiplier Application Tips](#) for additional power drive information.

8. REPLACING A SQUARE DRIVE ASSEMBLY

- 8.1 Remove the six screws (Fig. 3, Item 2) holding the reaction anchor plate (Fig. 3, Item 1) to the torque multiplier, and remove the reaction anchor plate from the torque multiplier.
- 8.2 Remove the pin engaging the gear cage with the output square drive and remove old output square drive.

- 8.3 Insert replacement square drive assembly into square drive carrier, aligning the hole in the lower portion of the replacement square drive with the hole in the square drive carrier.
- 8.4 Insert pin through hole in square drive carrier and into hole in replacement square drive.
- 8.5 Reattach reaction anchor plate to torque multiplier with the six screws removed in step 8.1.

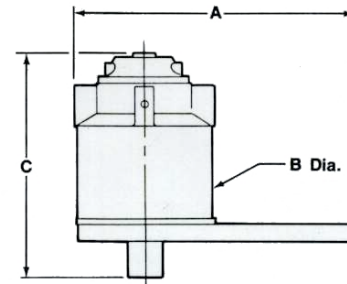

Figure 1. Torque Multiplier Dimensions

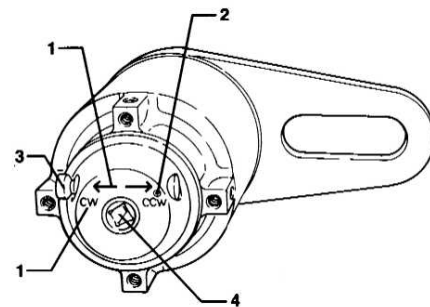

Figure 2. Input End Detail

1. Rotational direction indicators
2. Neutral positioning set screw
3. Selector pawl
4. 1/2" Female input square drive

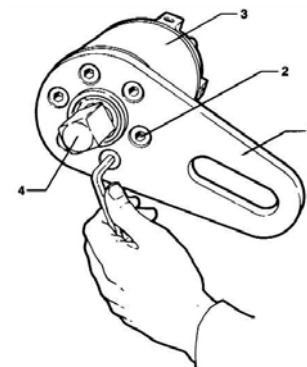

Figure 3. Changing the Anchor Plate

1. Reaction anchor plate
2. Attaching screws
3. Torque multiplier
4. Output square drive

Torque Multiplier Application Tips

1. INTRODUCTION

This section covers general torque multiplier usage. Some of the illustrations and information may not apply to your specific torque multiplier or application.

2. TORQUE MULTIPLIER REACTION

- 2.1 There are many different ways of absorbing torque multiplier reaction forces. Although the methods are as varied as the applications, there are common practices that should be taken into consideration.
- 2.2 The first item to consider is the size and type of torque tool required for the application. Survey space limitations as well as the maximum torque needed. Be sure to allow a minimum of 50% additional capacity in the tool for breakaway torque. Damaged and corroded fasteners can require even greater breakaway torque capacity. Allow a minimum of 100% over the make-up torque for these conditions. **Example:** A heat exchanger with corroded studs and a 1,500 Ft-Lbs. make-up torque. Choose a tool with a capacity of at least 3,000 Ft-Lbs. for breakaway.
- 2.3 Be sure that the anchor point is solid and has minimum deflection.
- 2.4 Determine where the reaction anchor forces are going to take place (e.g. against a flange or over an adjacent bolt). Make sure that this point can withstand the torque tool's reaction forces. For example consider a 3,200 Ft-Lb. torque multiplier, with reaction near the end of its anchor stub (figure 1). This will produce a reaction force of about 6,400 pounds. By moving the reaction to the end of the anchor tube, the force is reduced to about 2,400 pounds. Keeping the reaction point tangent to the rotation of the torque output is necessary to prevent the resultant forces from increasing even more (figures 2 and 3).
- 2.5 Keep output torque rotation as pure as possible by reducing bending moments. Bending moments decrease torque efficiency, reduce the torque applied to the application and are hard on the tool and sockets. This can be done by taking torque reaction as far out on the reaction anchor as possible. Also keep the distance between the tool's output and the fastener as short as possible (figure 2).
- 2.6 Keeping these factors in mind when devising a torque reaction system will help increase tool life and create a much safer working environment.

3. POWERED APPLICATION

- 3.1 When using air, electric or hydraulic tools to power torque multipliers, many variables must be considered before accurate results can be expected.

CAUTION: Impact type air tools should never be used with torque multipliers. Torque multiplier damage could occur.

- 3.2 Air tools operate best when clean, dry, well-lubricated air is used. The use of an air filter, lubricator and regulator are a must for reliable operation. It is also important to maintain enough airflow from the compressor's receiver. If the airflow (CFM) rating drops

below that expected by the air tool, lower than anticipated torque output may result.

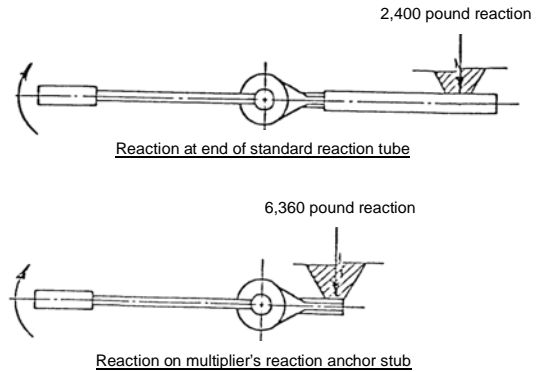

Figure 1
Reaction forces increase the closer the reaction point is to the multiplier.

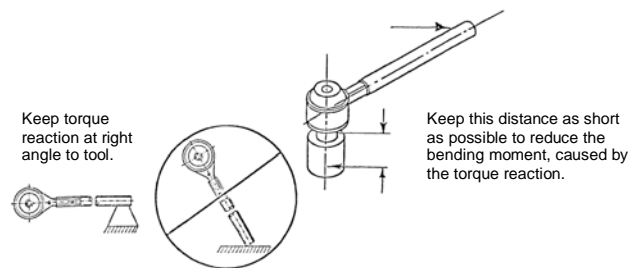

Figure 2
Minimize bending moments created by the torque multiplier's reaction.

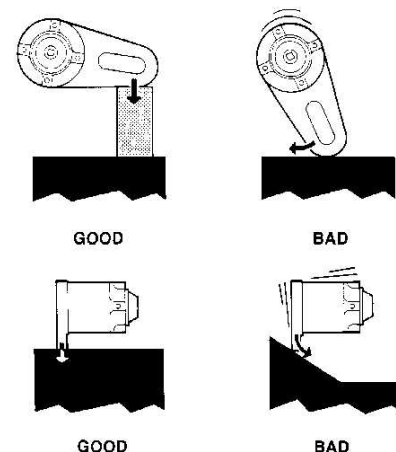

Figure 3
Keep reaction anchor perpendicular to the reaction point.

- 3.3 The simplest way to control the torque output is by regulation of the air pressure supplied to the air motor. The more accurate the air pressure control, the more reliable the torque control.
- 3.4 Attach an air pressure regulator as close to the air tool as possible. This will reduce pressure variations due to changes in air hose length & diameter or changes in quick disconnects and pipe fittings.
- 3.5 Dirty or corroded fastener threads can cause large fluctuations in the applied torque. It is recommended that a high quality lubricant be applied to the fastener threads as well as all other surfaces that rub. This will reduce losses in torque efficiency.
- 3.6 Changes in momentum of the air tool are the greatest cause of output torque variations. The higher the tools speed the greater the effects of momentum.
- 3.7 A soft stack-up has a large amount of application run-down time due to long studs, flat/lock washers, gaskets, etc. This will cause the air tool to run a longer time before reaching the desired torque. This decreases air motor momentum and decreased the applied torque. Conversely, a hard stack-up has a short run-down time due to short studs, very rigid application, etc. This will reach the desired torque very quickly, applying a greater torque to the fastener.
- 3.8 Angle nutsetters and inline air tools each have distinct advantages and disadvantages.
- 3.9 An inline air tool has the advantage of being fastened to the torque multiplier rigidly by bolting. This allows the operator to handle a single piece of equipment and the input torque reaction is absorbed by the bolted connection. The chief disadvantage is the tools height.
- 3.10 An angle nutsetter has the advantage of a lower tool profile but requires the tool operator to react the angle nutsetter's torque output. This reaction torque can be quite large (up to 200 Lb-Ft of torque) The reaction torque and the size of the air tool required can be reduced to under 40 Lbf-Ft by the use of an optional accessory gear box attached to the input of the torque multiplier. Although this does increase the tool height slightly, it is still lower in height than an inline tool.
- 3.11 If the angle nutsetter and torque multiplier are sized for the make-up torque required, a medium output (85 - 110 Ft-Lb.) angle nutsetter can be used. This combination will maximize the air tool speed while reserving some torque multiplier capacity for higher breakout torques. If necessary the fasteners can be broken loose manually, then run off can be completed using the air tool.

4. ANGLE OF TURN PROTRACTOR

- 4.1 Some torque multipliers include an Angle of Turn Protractor, which allows the operator to accurately measure a specific number of degrees of rotation of the fastener. The torque / angle of turn method of tightening fasteners requires a pre-torque value, and a specific additional rotation of the fastener, that is engineered into the application. This data will be supplied by the original equipment manufacturer's engineering department if angle of turn torquing is applicable.

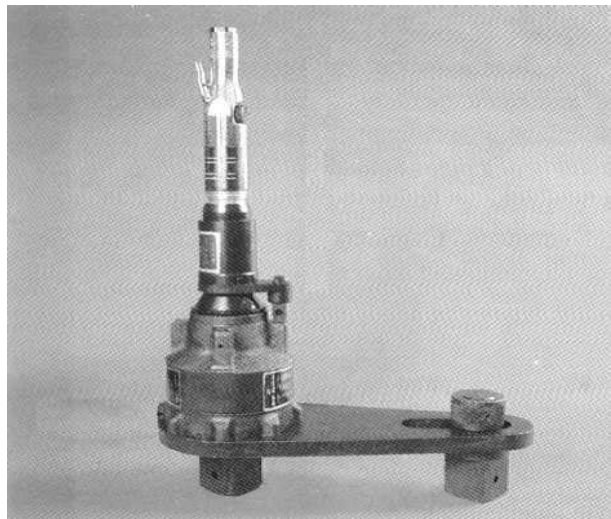
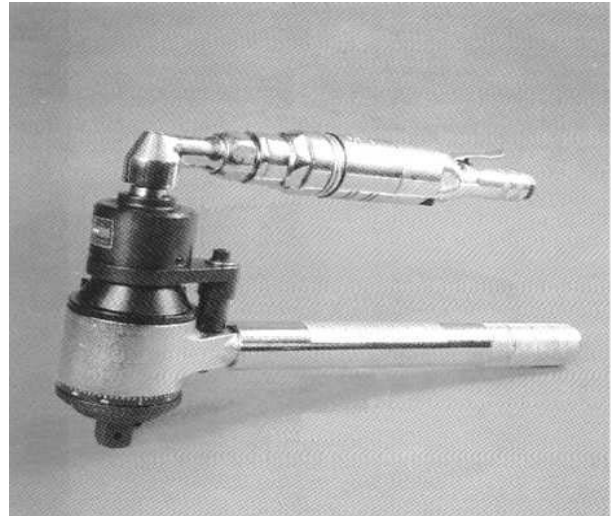
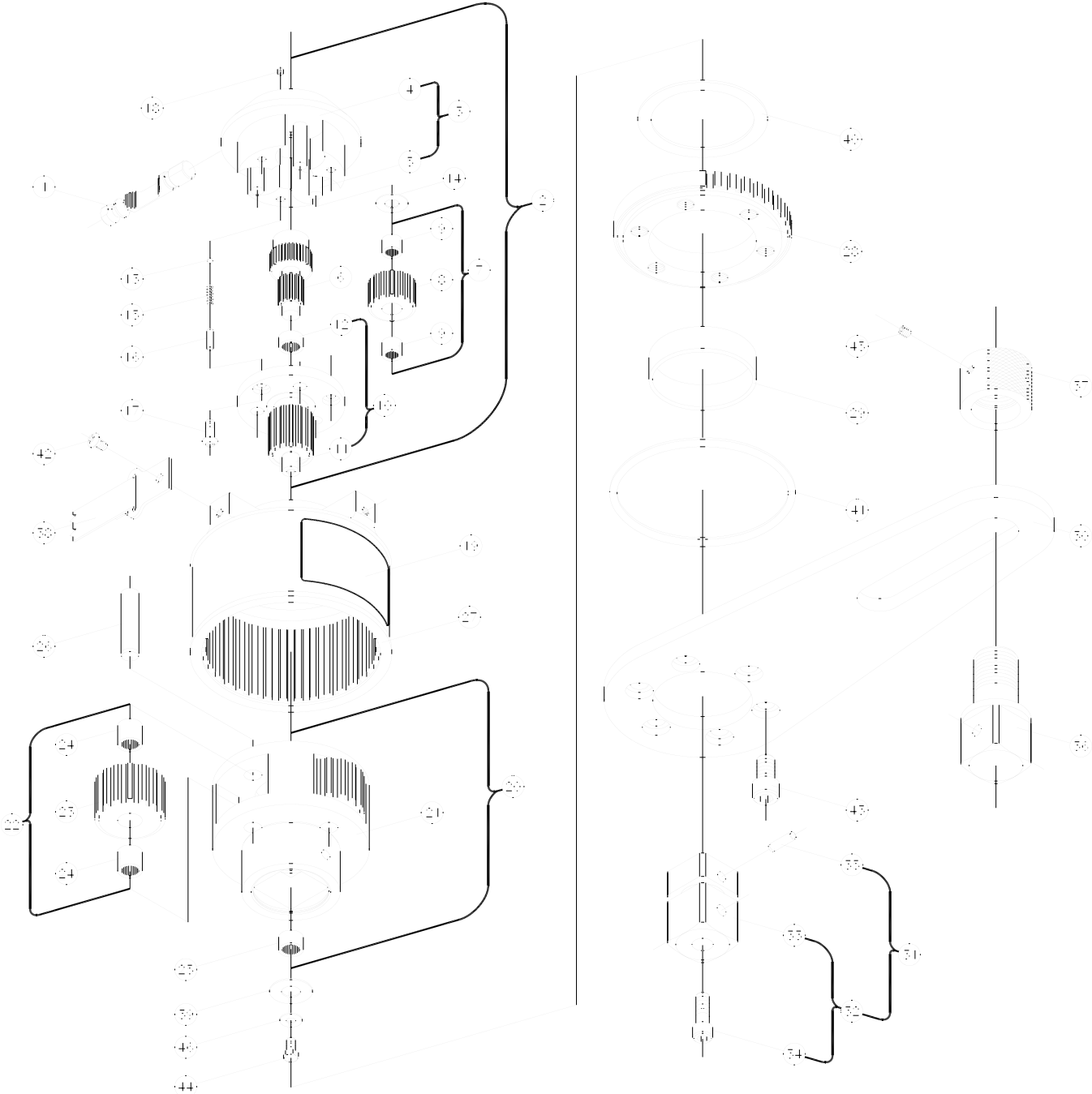

Figure 4
Torque multipliers with air motors attached for powered application.





Operating Manual

TM-394-OM
Page 6 of 6
Rev: B - 11/10

ITEM NO.	PART NUMBER	DESCRIPTION	QTY
1	392-14	SELECTOR PAWL	1
2	394-110	INPUT GEAR ASSEMBLY	1
3	394-11	INPUT END ASSEMBLY	1
4	394-12	INPUT END	1
5	A000141054001	DOWEL PIN	3
6	394-13	INPUT PINION	1
7	394-140	INPUT PLANET GEAR ASSEMBLY	3
8	394-14	INPUT PLANET GEAR	3
9	904066	BEARING	6
10	394-160	SECONDARY PINION ASSEMBLY	1
11	394-115	SECONDARY PINION	1
12	904084	BEARING	1
13	900001	7/32 DIAMETER BALL	1
14	906027	THRUST RACE	3
15	950019	SPRING	1
16	A000141012001	DOWEL PIN	1
17	A000151461001	B.H. SOCKET HEAD CAP SCREW	3
18	A000155798001	CUP PT. NYLOK SET SCREW	1
19	TM-394-201	NAME/DATA PLATE	1
20	394-210	OUTPUT GEAR ASSEMBLY	1
21	394-211	GEAR CAGE	1
22	394-220	OUTPUT GEAR ASSEMBLY	4
23	394-22	OUTPUT PLANET GEAR	4
24	904013	BEARING	8
25	904070	BEARING	1
26	A000141076001	DOWEL PIN	4
27	394-310	HOUSING	1
28	394-601	REACTION MOUNTING PLATE	1
29	394-602	BUSHING	1
30	394-611	REACTION ANCHOR	1
31	TM-394RSD	KIT, SQUARE DRIVE	1
32	394-71	SQUARE DRIVE SUB-ASSEMBLY	1
33	394-72	SQUARE DRIVE	1
34	A000152972001	LOW HEAD SOCKET CAP SCREW	1
35	A000141016001	DOWEL PIN	1
36	394-710	SLAVE DRIVE	1
37	394-711	SLAVE DRIVE RETAINER	1
38	394-80	CARRYING STRAP	1
39	9060019	THRUST RACE	1
40	906100	THRUST RACE	1
41	A000070027108	RETAINING RING	1
42	A000151453001	B.H.SOCKET CAP SCREW	2
43	A000151900001	SOCKET HEAD CAP SCREW	6
44	A000153001003	HEX HEAD CAP SCREW	1
45	A000155124001	CUP POINT SET SCREW	1
46	A000261026001	FLAT WASHER	1
47	913001	HEX KEY (NOT SHOWN)	1

NOTE: Indentation indicates component(s) of the previous lesser-indented assembly.