



Wogaard Coolant Saver™



Version 1.5-US

Instruction Manual

Preface

Thank you for purchasing the Wogaard Coolant Saver™. This unit is designed and optimized specifically for use with machine tools. It employs Wogaard’s resource-saving technology that saves you money on your coolant and cutting oil budget. Using the Wogaard Coolant Saver™ on machine tools equipped with chip-conveyors effectively reduces the impact on the environment from general machining operations, where coolant or cutting oil is used. All components are highly durable and should provide a trouble-free user experience for many years. Please read this manual to understand the functions and characteristics of the unit and keep it for future reference.



Christian Woergaard
Managing Director
WOGAARD LTD.

Wogaard Coolant Saver™

Instruction Manual

Table of contents

Preface	2
Table of contents	3
Safety precautions	5
Introduction	7
General description	7
Main components	8
Setup	9
Tools required for installation	9
Installation	10
Operation	17
Specifications	19
Product return	19
Warranty and liability	19
Technical assistance	20
Appendix A – Parts list	21
Appendix B – Troubleshooting	22

About this manual

This manual contains the instructions required for installing and operating the Wogaard Coolant Saver™. Read the instructions carefully before using the equipment!

Conventions

Within this manual, the following conventions are used:



Warning! Indicates an operation that may cause personal injury if precautions are not followed

Caution! Indicates an operation that may cause damage to equipment if precautions are not followed.

Note: Emphasizes significant information in a procedure or description.



Warning! PRODUCT USE LIMITATION

This product is designed and intended for installation and operation on the coolant system of a cnc-machine equipped with an automatic chip conveyor. The unit collects coolant or cutting oil from a chip-container and returns it to the cnc-machines main reservoir.

Using the product for anything other than prescribed in the “PRODUCT USE LIMITATION” is considered “unintended use”. Wogaard Ltd. cannot be held liable for any damages incurred from “unintended use”.

Safety precautions

In order to ensure correct and safe use of the equipment, and to avoid any disturbances to operations, it is vital to have read and understood the basic safety precautions set out on these pages.

Any person using the equipment must comply with these instructions and safety precautions, and also any company specific safety procedures that complement this (if applicable).

This instruction manual must be kept in immediate proximity to the place where the unit is installed, so that it is visible to the operator of the equipment. Safety precautions and warnings must be placed permanently and clearly visible near the equipment.

Employer obligations:

The employer is obliged to ensure that only people, who meet the following conditions, may use the equipment.

People who:

1. Have had proper instructions on the use of the equipment.
2. Have read these basic safety precautions.

Warning!

Always turn off the machine driving the coolant pump, when installing the equipment.

When the equipment is installed you can shut off the ball valve and remove the venturi-unit, by unscrewing it from the ball valve. This allows for cleaning or inspection, if necessary, without interrupting the machine operation.

Warning!

Do not try to separate the unit from the machine piping during operation if the unit is installed in a cramped space, where it may be difficult to move the hand-tools freely.

If you suspect the equipment to be faulty, shut off the ball valve immediately and contact the manufacturer to resolve the issue.

Residual risk

In spite of all safety measures, personal safety equipment and optimum organization safety procedures, it is not possible to rule out damages to other equipment or even personal injury.

Should an accident occur, you must inform the manufacturer. The manufacturer has an obligation to monitor the products, in order to take appropriate action, through the ongoing product development, to prevent or eliminate all risk elements associated with this equipment.

Introduction

The Wogaard Coolant Saver™ is designed to enable re-use of the cutting fluid that normally ends up in chip-containers when cnc-machines employ automatic chip-conveyors.

When chips are removed from the machining process, the chip-conveyor carries drops of cutting fluid with it. The cutting fluid also hangs onto the large surface area of the chips and ultimately ends up in the bottom of the chip container. From here the Wogaard Coolant Saver™ collects the fluid through a vacuum cup, and returns it to the cnc-machines main reservoir.

General description

The equipment consists of a vacuum cup which is placed on the bottom surface of the chip container, and a venturi-unit that branches off the pipe supplying coolant or cutting fluid to the machine tool. The pressure from the machine tools coolant pump creates a constant flow through the venturi-unit, which generates a vacuum at the vacuum cup. The vacuum cup is connected to the venturi-unit using a 6mm PU hose. The vacuum cup collects the coolant or cutting oil from the bottom of the chip container and leads it to the venturi-unit.

The venturi-unit is fitted with a ball-valve so it can be shut off if needed. A 12mm PU hose mounted on the bottom end of the venturi-unit leads the collected liquid back to the machine tools main reservoir. The vacuum cup is fitted with a filter mesh to prevent chips and small debris from entering the system. The vacuum cup and filter is made from high quality stainless steel.

The main components are listed on the following page.

Main components

- 1. Ball valve
- 2. O-Seal
- 3. Venturi nozzle
- 4. Venturi
- 5. Support bushing
- 6. End nut
- 7. 6mm PU hose
- 8. Vacuum cup
- 9. Filter plate
- 10. Filter mesh
- 11. Circlip ring

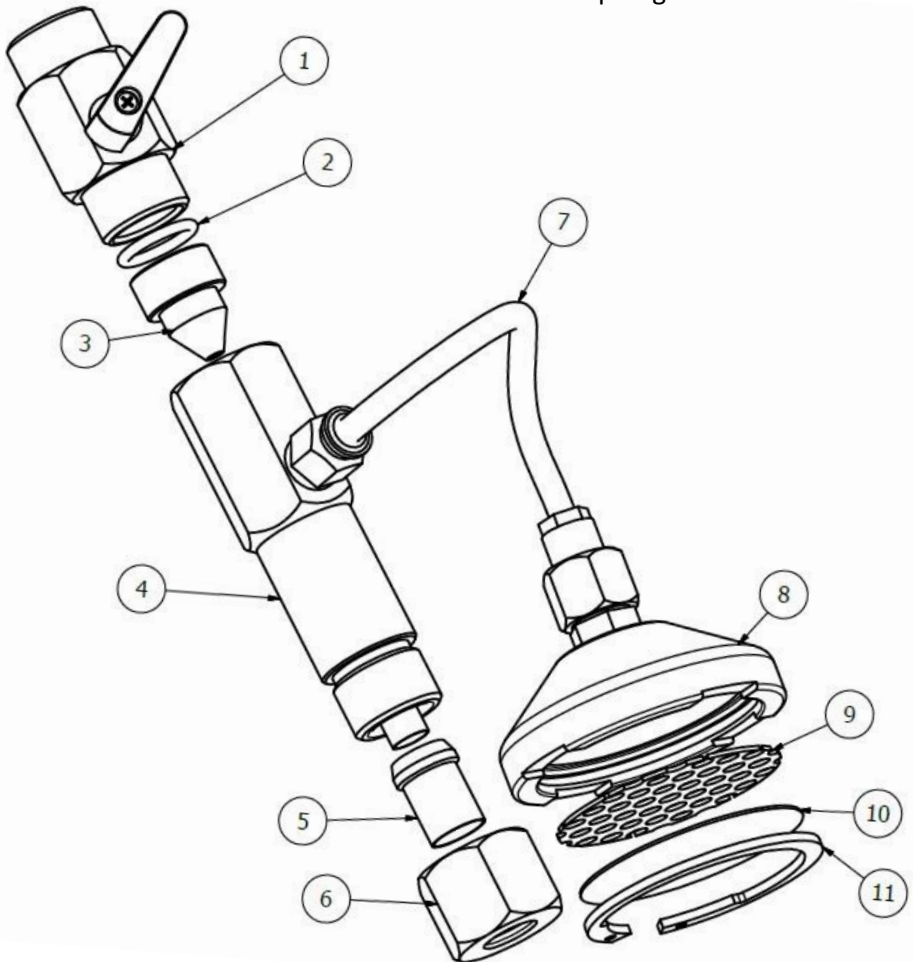

Setup

Tools required for installation

For the installation of the Wogaard Coolant Saver™ you should be in possession of the following tools:

One medium size pipe wrench



Utility knife for shortening the PU hoses



25mm spanner



Pipe thread seal tape to seal pipe fittings



Alternatively you could use an 8" adjustable wrench

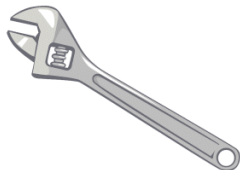

Installation

The illustration below shows the typical installation scenario. A vertically mounted coolant pump, that may, or may not be equipped with a filter-unit.

NOTE: *On machine tools where the coolant pump is equipped with a filter-unit the Wogaard Coolant Saver™ should be installed **after** the filter-unit (as shown in figure 3 and 4).*

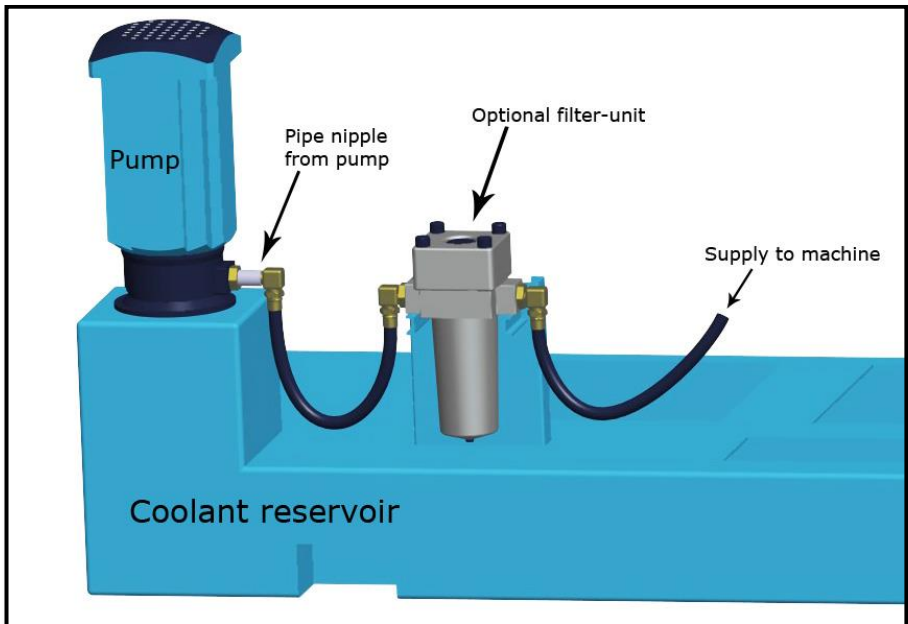

Fig. 1

1. Determine the size of the thread on the pipe nipple, coming from the coolant pump or filter unit if applicable.

The thread size is $\frac{1}{2}$ inch or $\frac{3}{4}$ inch on most installations. Pipe nipples and T fittings are supplied with the product for these two sizes. If you encounter a different size thread, or you experience difficulty in determining a suitable composition of the components, you should contact the manufacturer or purchase suitable pipe fittings.

Tip: Take a picture of the pipes branching off the coolant pump or filter-unit, and send it to support@wogaard.com and our team will contact you with suggestions for installing the components.

2. Ensure that the pump is turned off, and cannot be started during installation. It is recommended to put up a sign that clearly warns not to turn on the pump or machine while the installation is in progress.

3. The hose supplying cutting fluid to the machine tool is disconnected at the location specified in the illustration below (Fig.2).

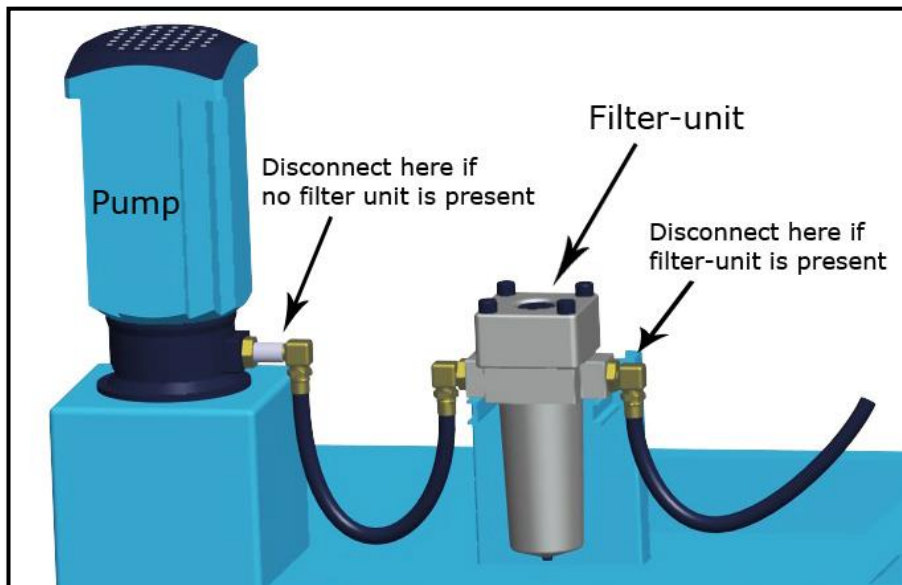

Fig. 2

4. Screw on the suitable T fitting or pipe nipple onto the coolant pump or filter-unit, as shown in the example below (Fig 3)

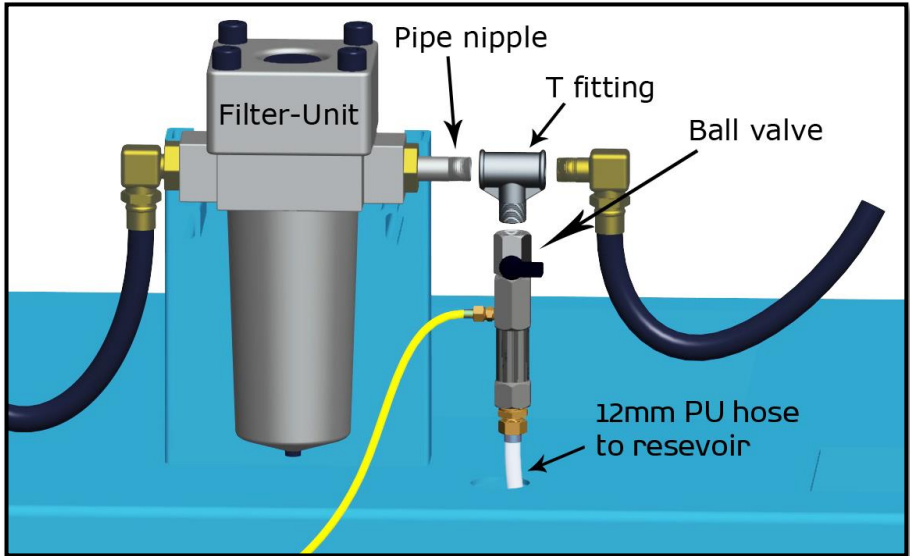

Fig. 3

In this particular example (Fig 3), the pipe nipple is screwed into the filter-unit, and the T fitting is then screwed onto the pipe nipple.

5. Screw the venturi-unit and ball valve onto the vertical branch of the T fitting as shown above (Fig 3).

Ensure that the ball valve is shut off and the flow-indication-arrow on the side of the venturi-unit is pointing away from the pipes, and down towards the coolant reservoir.

6. The 12 mm PU hose is inserted at the end of the venturi-unit pointing towards the ground. The hose should be cut to length with a utility knife, so the end of the hose is approx an inch above highest possible water-level.

Caution: Avoid bending the 12mm hose. Please ensure that the hose is mounted in a way that prevents it from shifting position, as a result of changes in flow. You should drill a 12.5 - 14 mm hole in the top plate of the coolant reservoir to accommodate the 12mm PU hose. If you feel uncomfortable doing this, you can alternatively fix the hose in an appropriate manner using regular cable ties. THE HOSE MUST NOT TWIST OR BEND SHARPLY!

7. Place the vacuum cup on the bottom surface of the chip container. One end of a 6mm PU hose is attached to the vacuum cup. The other must be inserted into the 1/8" push-in connector on the side of the venturi-unit (see fig. 4).

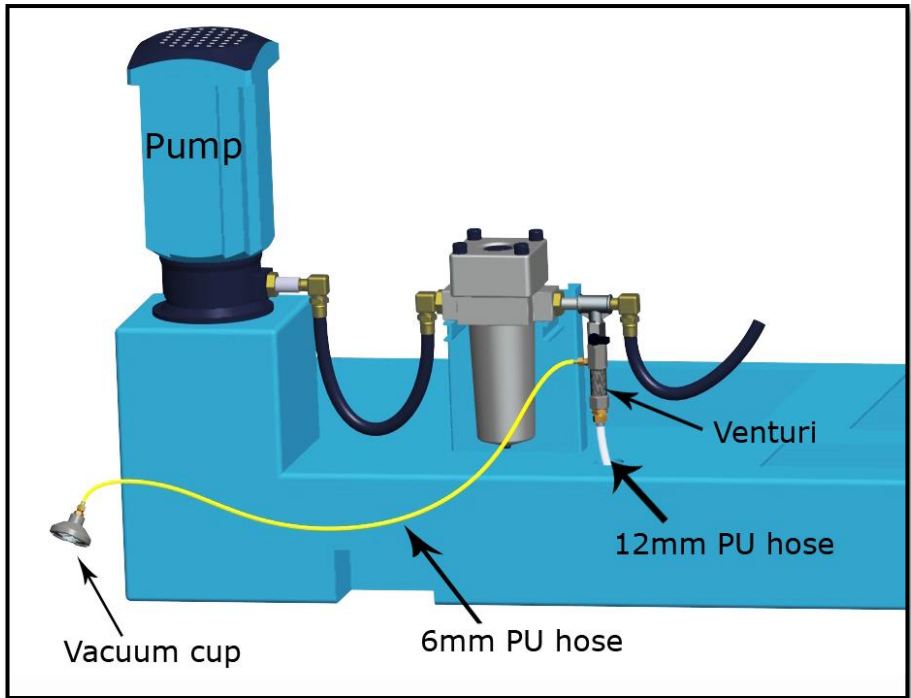

Fig. 4

8. Connect the hose supplying cutting fluid to the machine, to the end of the T fitting as shown in Fig. 3 and Fig. 4.

Tip: If you are machining materials that produce very dense or heavy swarf, such as cast iron or steel, it can prove useful to install a tube in one corner of the chip container, as shown in the picture below (Fig. 5). This can be done with screws or spot welding. It will make it easier to pull out the vacuum cup from a container full of chips.



Fig. 5

Chip container with square profile tube spot welded in one corner.

Operation

When the equipment is installed as prescribed in the previous chapter (Installation), it is ready for operation.

1. Set the ball valve in the "shut off" position, as shown in Fig. 6 below.

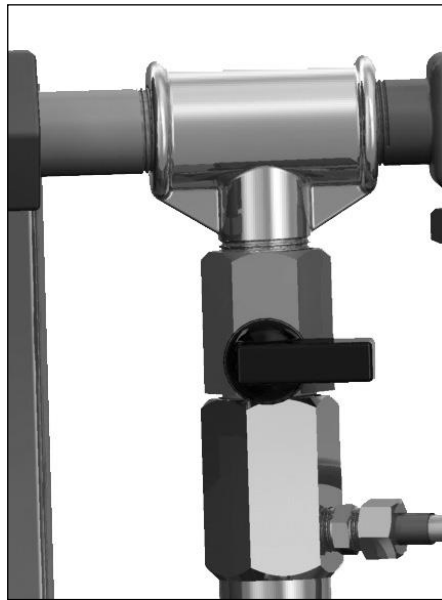

Fig. 6

2. Start the coolant pump.

Warning!

If any leaks, breakage or sharp bends to hoses is observed, when turning on the coolant pump. Turn off the coolant pump and remediate the issue.

3. Open the ball valve, until suction can be registered at the vacuum cup. Opening the ball valve half-way, as shown in fig. 7 below, is usually enough to generate the vacuum.

Note: The vacuum or collection flow-rate, is not proportional with the liquid volume flowing through the venturi-unit. Simply open the ball valve enough to create a vacuum effect

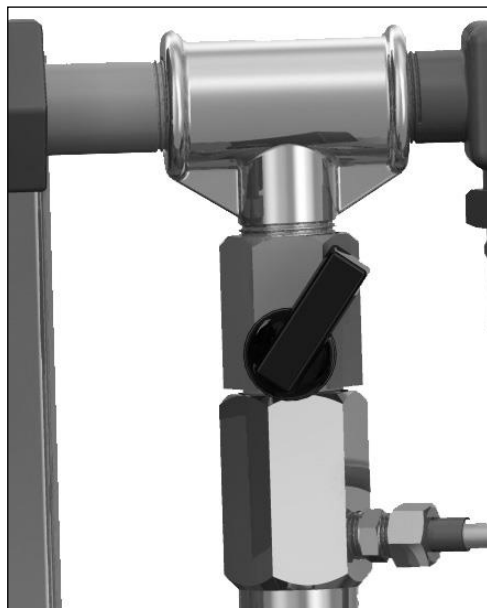

Fig. 7

The system is now operating as intended, and no further adjustment is needed.

You do not need to shut off the equipment when changing the chip container. Simply pull out the vacuum cup from the current container, and place it in the new container.

Specifications

Fluid	Water-soluble cutting fluid / Non-water-soluble oil
Operating pressure	3 to 650 psi
Suction capacity	-7 to -11 psi
Collection flow rate	Approx. 15 gal/hour.
Mounting height	Max. 10 ft.
Collection tube length	Max. 30 ft.

Product return

To limit charges and delays, contact the seller or manufacturer for authorization and shipping instructions before returning the product, either within or outside of the warranty period. When returning the product, please state the reason for the return. For your protection, pack the product carefully and insure it against possible damage or loss. Any damages caused by improper packaging are your responsibility.

Warranty and liability

The warranty period is **1 year** from the date of delivery. During the warranty period, the manufacturer will repair or replace any components that may be damaged as a result of manufacturing defect(s), free of charge.

Any expense or other damage incurred during operation, as a result of using the equipment, is not covered under the warranty.

When the equipment has been delivered to the customer, Wogaard LTD. is NOT responsible for any damages caused by the equipment:

- A. To machinery or any property of the customer.
- B. To products manufactured by the customer or to products wherein these are used.

Under no circumstances can the manufacturer or vendor be held responsible for any consequential loss, lost profit or other financial consequences.

Technical assistance

If you have any questions about the use of this product, contact the manufacturer or authorized reseller.



WOGAARD LTD.

823 Salisbury House
29 Finsbury Circus
London EC2M 5QQ

Email: info@wogaard.com
Phone: +44 (0)7557 107892
Web: www.wogaard.com

Copyright

This instruction manual is intended for customers who have purchased the Wogaard Coolant Saver™ equipment only. The copyright for this material belongs to WOGAARD LTD. The customer may reproduce this material for personal use.

Appendix A – Parts list

The following is a list of parts that make up the Wogaard Coolant Saver™ assembly.

Index	Part No.	Description	QTY
1	144-1001	Venturi-unit	1
2	144-1204	Venturi nozzle	1
3	144-1804	O-Seal	1
4	144-0404	Ball valve	1
5	144-1604	1/8" Push-in connector (for 6mm PU hose)	1
6	144-1404_2	End nut (for 12mm PU hose)	1
7	144-0803	6mm PU hose (3 Metres)	1
8	144-0603	12mm PU hose (1.5 Metres)	1
9	144-2002	Vacuum cup	1
10	144-2604	1/4" Push-on connector (for vacuum cup)	1
11	144-2604_2	¼" check valve	1
12	144-2203	Filter plate	1
13	144-2403	Filter mesh	1
14	144-2804	Circlip ring	1
15	-	1/2" Pipe nipple	1
16	-	1/2" T-fitting	1
17	-	3/4" Pipe nipple	1
18	-	3/4" T-fitting	-

Appendix B – Troubleshooting

If there is no suction at the vacuum cup, and no liquid is being collected, try the following steps to resolve the issue.

- Blow air into the vacuum cup, using a regular air blow gun. This can clear out any small debris that may have set inside the venturi-unit or nozzle, and in most cases this will resolve the issue and re-establish the vacuum.
- If the above procedure does not resolve the issue, it may be necessary to shut off the ball valve, and unscrew the venturi-unit. Once the unit is disconnected from the ball valve, you can use a small diameter drill or hex key (allen key), to pull out the o-seal and then the venturi nozzle. Remove any chips or debris that may have clogged the venturi or nozzle, and put the unit back together. Use the illustration in the “Main components” section, of this manual, as a reference when assembling the unit if required.

Although the venturi-unit and the nozzle are designed and optimized to avoid debris and chips from clogging the system, it can occur in scenarios where larger chips or debris is allowed to pass through the coolant pipe system.

You can always contact the manufacturer with questions regarding the installation or operation of this product.

